

# THE SYNTAX OF SMALL CLAUSES

A Thesis

Presented to the Faculty of the Graduate School

of Cornell University

in Partial Fulfillment of the Requirements for the Degree of

Master of Arts

by

Julie Elizabeth Balazs

August 2012

© 2012 Julie Elizabeth Balazs  
ALL RIGHTS RESERVED

## **ABSTRACT**

This thesis presents a historical review of literature on small clauses, typically defined as tenseless [NP XP] structures, where XP is non-verbal. Additionally, this thesis argues for a universal structure for small clauses. The structure is binary-branching and contains a functional predicational projection, referred to here as PrP. The range of possible syntactic properties of the Pr head explains the differences in small clauses cross-linguistically. The structure argued in this thesis is based primarily on data from English, Russian, Irish, Chinese, and Polish. The syntactic possibilities of the T head and Pr head in combination can explain the range of copular clauses cross-linguistically.

## **BIOGRAPHICAL SKETCH**

Julie Balazs received her undergraduate M.A. from the University of Edinburgh in English language and English literature. From 2006 until 2008, she taught courses in the English department at William Rainey Harper College in Palatine, IL. She began graduate work in linguistics at Cornell University in 2008, and since 2010 has worked towards a professional M.S. in speech-language pathology at Ithaca College. Her research examines diverse language-related topics, from theoretical syntax to the sociolinguistics of non-native English in predominantly English-speaking environments.

This thesis is dedicated to Kyle Grove, who mixes the best sixes.

## **ACKNOWLEDGEMENTS**

I am immensely grateful to Zhong Chen, Magdalena Kanik, and Hamza Mahmoud, who were enthusiastic and thoughtful language consultants; and to John Bowers and Wayne Harbert, who were exceedingly patient and insightful. Special thanks to Sergio Gelato, who crafted a LaTeX style file for his Cornell dissertation and then generously made it available to all Cornell students. Thank you to the excellent folks at Ithaca Coffee Company and the Donkey: without such tasty coffee, calming playlists, and motivating work spaces, this thesis would still be a three-page outline. And of course, thanks to Kyle Grove, for listening to my ideas and asking smart questions.

## TABLE OF CONTENTS

Biographical Sketch . . . . .	iii
Dedication . . . . .	iv
Acknowledgements . . . . .	v
Table of Contents . . . . .	vi
List of Figures . . . . .	vii
<b>1 Introduction</b>	<b>1</b>
<b>2 Background: The structure of small clauses</b>	<b>4</b>
2.1 Predication vs. Constituency . . . . .	4
2.2 The category of small clauses . . . . .	14
2.2.1 Small clauses are S . . . . .	14
2.2.2 Small clauses are S' . . . . .	16
2.2.3 Small clauses are PrP . . . . .	19
2.3 The predicator head . . . . .	33
<b>3 Rejecting a structural typology of small clauses</b>	<b>46</b>
3.1 English-type and Irish-type . . . . .	46
3.2 English-type and Chinese-type . . . . .	52
<b>4 PrP and copular clauses</b>	<b>65</b>
4.1 Copular clauses in Polish, Arabic, and Welsh . . . . .	65
4.2 Copular clauses in Irish . . . . .	84
<b>5 Conclusion</b>	<b>91</b>

## LIST OF FIGURES

2.1	Stowell’s small clause constituent . . . . .	9
2.2	Ternary-branching predication structure . . . . .	10
2.3	Raising verb taking a small clause complement . . . . .	11
2.4	‘Someone seems sick’ under Predication . . . . .	11
2.5	Ternary-branching means not all small clauses can share the same structure. . . . .	13
2.6	Small clause as category S . . . . .	14
2.7	The structure of PrP . . . . .	20
2.8	The structure of a tensed clause . . . . .	21
2.9	<i>Consider</i> takes a small clause complement. . . . .	22
2.10	Raising verbs take small clause complements . . . . .	26
2.11	Raising verb without matrix PrP . . . . .	30
2.12	Unaccusatives do project PrP . . . . .	32
2.13	Russian at LF . . . . .	35
3.1	Clause structure in Irish . . . . .	47
3.2	Structure of Irish small clauses . . . . .	48
3.3	Clause structure in English . . . . .	48
3.4	Ternary-branching VP . . . . .	49
3.5	The structure of <i>Tharlaigh [cuid mhór daoine ar meisce an lán sin]</i> (“It happened that many people were drunk that day”). The bracketed phrase is a small clause. . . . .	50
3.6	‘Not-so-bare’ small clause, per Tang (1998) . . . . .	55
3.7	‘Bare’ small clause, per Tang (1998) . . . . .	56
4.1	Polish copular sentence with complete Pr head (‘Maria is wise’) . . . . .	69
4.2	Polish copular sentence with defective Pr head (‘Warsaw is the capital of Poland’) . . . . .	70
4.3	Arabic present-tense copular sentence (‘Omar is a teacher’) . . . . .	73
4.4	Arabic past-tense copular sentence (‘Omar was a teacher’) (Benmamoun, 2008) . . . . .	74
4.5	Arabic present-tense copular sentence (‘Omar is a teacher’) (Baker, 2003) . . . . .	75
4.6	Arabic past-tense copular sentence (‘Omar was a teacher’) (Baker, 2003) . . . . .	76
4.7	Pure Small Clause Copula (‘John is my best friend’) . . . . .	78
4.8	Pure Equative Copula (‘John is my best friend’) . . . . .	79
4.9	Equative Small Clause Copula (‘John is my best friend’) . . . . .	81
4.10	Tensed preverbal particles in Irish . . . . .	86



CHAPTER 1  
INTRODUCTION

A well-known problem in syntax is what structure to assign to small clauses, where a small clause is an [NP XP] construction, as in the following:

- (1) a. Mayor Shinn found [Harold difficult to pin down]
- b. Marcellus considered [Harold a great con man]
- c. The people of River City thought [Harold in the wrong]

Small clauses are widespread. In English alone, they are the complements of verbs, complements of prepositions as in (2-a), subjects of sentences as in (2-b), or even subjects of small clauses as in (2-c):

- (2) a. With [Charlie Cowell intent on ruining him], Harold wasn't safe
- b. [Tommy and Zaneeta in a relationship] wasn't/\*weren't good for Mayor Shinn's blood pressure
- c. Eulalie considered [[Tommy and Zaneeta in a relationship] bad for Mayor Shinn's blood pressure]

Additionally, small clauses appear in many languages, for example French and Chinese:

- (3) a. Je crois [Jean malade]. (French)  
      I believe Jean sick  
      "I believe John sick"
- b. Zhangsan dang ta shagua. (Chinese)  
      John consider he fool  
      "John considered him a fool"

Consequently, the small clause has long been an object of interest, but 30 years of research has brought theoretical syntax no closer to consensus regarding the status of small clauses and their structure. Are they mediated by a functional head? Are they TPs? Are they same size cross-linguistically, or within the same language? At the most basic level, scholars cannot even agree whether they are constituents; as recently as 2010, Williams was still arguing that small clauses are non-constituent elements of a ternary-branching VP.

With that in mind, this thesis is an attempt to provide a unified structural analysis of small clauses. I revisit the key small clause literature and its relevant data in depth, focusing on multiple languages, English, Russian, Irish, Chinese and Polish. The comparison suggests the adoption of a single structural model for small clauses. The model is supported by new Chinese data I discuss at length here. The inclusion of Chinese is critical as it extends the model beyond Indo-European.

In part, this thesis is a historical survey, and as such I attempt to discuss the existing literature within its contemporary syntactic framework. For example, I describe Hornstein and Lightfoot (1987) and Kitagawa (1985) within the context of Government and Binding, using now-obsolete category labels (e.g. S and INFL) and structural machinery (e.g. singly-articulated phrases without specifier positions, like S'). Consequently, associated phrase structure diagrams show unary branching, which was licit within X-bar theory.

My own analysis, however, is firmly within the existing Minimalist framework (Chomsky 1993, 1995), and makes several widely accepted theoretical assumptions. These assumptions include strict binary-branching (Kayne, 1984) and Bare Phrase Structure (Chomsky, 1994). By definition Bare Phrase Structure does away with category labels, relying instead on the syntactic properties of heads and their interactions

with other heads to derive phrase structure. In this vein, phrase structure diagrams within my own analysis eliminate unary branching; but for ease of the reader, I follow other authors in using category labels as shorthand in diagrams and in my discussion. Further, this thesis also assumes cyclic spell-Out (Uriagereka, 1999) which necessitates cyclic movement.

Central to this thesis is a syntactic conception of argument structure, in which an argument's structural position determines its grammatical function (subject, direct object, etc.). The model of subject-hood espoused here, which supports Bowers's (1993) PrP (and to a lesser extent Chomsky's (1995) vP-shell), is largely based on pre-Minimalist findings. An early attempt to define subjects structurally is found in Stowell (1981, 1983). Larson (1988) proposed nested VPs for double-object constructions. Pollock (1989) moved subjects to a functional phrase, AgrP. Koopman and Sportiche (1991) proposed the VP-internal subject hypothesis, in which the subject is generated relatively close to the verb – structurally lower than previously assumed.

The thesis proceeds as follows: in Chapter 2, I give an overview of the core small clause literature. I show that small clauses are constituents and discuss at length several proposed categories for small clauses, XP, S, S' and PrP; and conclude that small clauses are best analyzed as PrPs, larger than the lexical phrase but smaller than TP. In Chapter 3, I re-examine known data from Irish and Chinese. Based in part on new Chinese data, I refute two attempts to show that small clauses do not have the same structure cross-linguistically and show that small clauses in these languages conform neatly to the PrP model. In Chapter 4, I consider the popular claim that, within a PrP (or equivalent) model, copular verbs are overt Pr heads. I argue that this is overly simplistic, and looking at Polish, Arabic, Welsh, and further Irish data, I explore more fully the range of possible syntactic behavior of Pr heads in relation to copular sentences.

## CHAPTER 2

### BACKGROUND: THE STRUCTURE OF SMALL CLAUSES

## 2.1 Predication vs. Constituency

The earliest use of the term ‘small clause’ is in Williams (1975), who uses the term in reference to reduced relatives, adverbial modifier phrases, and gerundive phrases, like these:

- (1) a. The man [driving the bus] is Norton’s best friend
- b. John decided to leave, [thinking the party was over]
- c. [John’s evading his taxes] infuriates me

However, this project is not concerned with these structures. Rather, it is concerned with the type of structure that generative grammar now refers to as a ‘small clause’, [NP XP] structures where NP and XP are in a subject-predicate relationship, and XP is NP, AP or PP, as follows:<sup>1</sup>

- (2) a. *John is sad*
- b. John ate [*the meat*] *raw*
- c. *John* ate the meat *nude*
- d. John made *Bill mad*
- e. John considers *Bill silly*

---

<sup>1</sup>See Section 2.2.3 for a brief discussion of [NP VP] constructions.

This type of structure was first singled out for study by Williams (1980), who proposed that the italicized phrases in the sentences above are instances of Predication, his formalization of the subject-predicate relationship as one based on co-indexation. A subject and predicate are co-indexed at Predicate Structure, a new stage of derivation in which a subject and predicate (and any traces of the predicate) are co-indexed.

According to Williams, we can reduce many syntactic phenomena to this kind of co-indexation, including control (3-a) and purpose clauses (3-b) and cleft sentences (3-c), where we should consider the embedded clause a complex predicate and co-index the entire clause to a subject:

- (3) a. John wants *Bill [to win]*
- b. I bought *it [to give to Pete]*
- c. It was *John [that I saw]*

He stresses that the subject-predicate relationship relies on c-command. The subject must c-command the predicate and any traces of the predicate. In the Predication theory, a subject is not defined in structural terms, but rather through co-indexation: any NP co-indexed with a predicate is the subject of that predicate. Consequently, the subject and predicate need not form a constituent at any stage of derivation. The subject-predicate relationship – and therefore the semantic units formed in Predicate Structure – is primitive. Clauses – and therefore the notion of constituent – are merely by-products of Predication. Despite an assumption of structural c-command, Williams (1980) does not propose a structure, binary-branching or otherwise, for any sentence or phrase, with the consequence that he must make several stipulations to ensure that the right subject is co-indexed with the right predicate.

Stowell (1981, 1983) was the first to apply the term ‘small clause’ to and propose a structure for the sentences of interest. Stowell argues that ‘subject’ is a purely structural notion: any NP in the specifier position of a phrase is a subject. He points out the well-known fact that not all categories have lexical subjects – infinitive clauses, for example. Following Chomsky, Stowell argues that Structural Case accounts for the distribution of lexical NP subjects, which may only occur where they are assigned Case. Infinitives, e.g., cannot assign Case, so a lexical NP cannot occur in the specifier position of an infinitive clause. But this does not mean that an infinitival INFL does not project IP with its corresponding specifier position: it merely means that lexical NP cannot occur in spec-IP.

Until Stowell, only NP and S (where S = IP) were thought to license lexical NPs in their specifier positions:

- (4)
- a. [<sub>IP</sub> John [<sub>I'</sub> saw Bill]]
  - b. [<sub>NP</sub> John's [<sub>N'</sub> extreme tallness]] annoyed me
  - c. \* [<sub>AP</sub> John(s) [<sub>A'</sub> very tall]] annoyed me
  - d. \* [<sub>PP</sub> John(s) [<sub>P'</sub> in the garden]] annoyed me
  - e. \* [<sub>VP</sub> John(s) [<sub>V'</sub> watch TV]] (annoyed me)

Stowell suggests that under the right circumstances, i.e. provided that Structural Case is assigned, the specifier positions of categories other than S and NP – including AP, VP, and PP – could potentially be filled with lexical NPs. He points to instances of *of*-insertion in APs and Exceptional Case Marking in infinitival Ss:

- (5)
- a. That was [<sub>AP</sub> nice of [<sub>NP</sub> John]]
  - b. [<sub>AP</sub> Very clever of [<sub>NP</sub> you]], Bob!

- c. I consider [<sub>S</sub> John [<sub>INFL</sub> to be very stupid]]
- d. I expect [<sub>S</sub> the chicken [<sub>INFL</sub> to cross the road]]

A natural question is whether lexical NPs can ever occur in PPs or VPs, in APs without *of*-insertion, or in NPs without Genitive Case marking. Stowell firmly answers ‘yes’, and identifies what he refers to as small clauses, whose subjects receive Structural Case from the matrix verb, as in ECM constructions:

- (6) a. I consider [<sub>AP</sub> John [<sub>A'</sub> very stupid]]
- b. I expect [<sub>PP</sub> that sailor [<sub>P'</sub> off my ship]]
- c. We feared [<sub>PrTP</sub> John [<sub>Prt'</sub> killed by the enemy]]
- d. I saw [<sub>VP</sub> John [<sub>V'</sub> come into the kitchen]]

These structures are not an artifact of English; we observe these types of constructions cross-linguistically, as in French:<sup>2</sup>

- (7) a. Je crois [<sub>AP</sub> Jean malade]  
I believe John sick  
“I believe John sick”
- b. J’imagine [<sub>AP</sub> son frère intelligent]  
I imagine his brother intelligent  
“I imagine his brother intelligent”

---

<sup>2</sup>Note that the corresponding ECM constructions, while acceptable in English, are ungrammatical in French:

- (i) a. \*Je crois Jean être malade  
I believe John to be sick  
“I believe John to be sick”
- b. \*J’imagine son frère être intelligent  
I imagine his brother to be intelligent  
“I imagine his brother to be intelligent”

and Swedish (Lundin, 2003):

- (8) a. Jag hörde [<sub>VP</sub> henne sjunga]  
I heard her sing  
“I heard her sing”
- b. Med [<sub>AP</sub> händerna knutna] sprang Pelle framåt  
With hands-the clenched ran Pelle forward  
“With hands clenched, Pelle ran forward”
- c. Kalle ansåg [<sub>AP</sub> Lisa dum]  
Kalle considered Lisa stupid  
“Kalle considered Lisa stupid”
- d. Man benämner [<sub>DP</sub> dem enzymer]  
One labels them enzymes  
“They are labelled as enzymes”

and Spanish (Contreras, 1987):<sup>3</sup>

- (9) a. Considero claro el asunto  
I consider clear the matter  
“I consider the matter clear”
- b. Juan considera el mejor juez de él a Pedro  
Juan considers the best judge of him to Pedro  
“Juan considers Pedro the best judge of him”

Small clauses are further like IPs in that they, too, have PRO subjects when Case is not assigned, for example when functioning as depictive adjuncts:

---

<sup>3</sup>As in French, the corresponding ECM constructions are unacceptable:

- (i) a. \*Considero ser inteligente a Juan  
I consider to be intelligent to Juan  
“I consider Juan to be intelligent”
- b. \*Considero estar claro el asunto  
I consider to be clear the matter  
“I consider the matter to be clear”



- (10) a. Scott wandered home [<sub>AP</sub> PRO drunk]  
 b. The farmer loaded the truck [<sub>AP</sub> PRO full of hay]  
 c. Jack rolled the dough [<sub>PP</sub> PRO into a ball]  
 d. Jack emerged from the meeting [<sub>PTP</sub> PRO confused by their reaction]  
 e. Prefiero la carne bien cocida  
 I prefer the meat well cooked  
 “I prefer the meat well-done”<sup>4</sup>

Additionally, small clauses can participate in raising constructions, in which they have trace subjects, per Chomsky (1981):

- (11) a. John<sub>i</sub> became [<sub>NP</sub> t<sub>i</sub> George’s sworn enemy ]  
 b. The truck<sub>i</sub> seemed [<sub>AP</sub> t<sub>i</sub> full of hay]  
 c. At first John<sub>i</sub> appeared [<sub>PP</sub> t<sub>i</sub> in the know], but he quickly revealed his ignorance  
 d. Fernando<sub>i</sub> looks like [<sub>NP</sub> t<sub>i</sub> a model]

Ultimately, Stowell here formulates the Constituency model of small clauses, in which a small clause is a binary-branching maximal projection whose specifier is the subject of the head, as shown below:

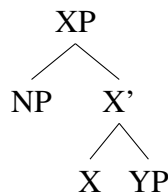

Figure 2.1: Stowell’s small clause constituent

---

<sup>4</sup>This sentence from Contreras (1987)

By adhering to a binary-branching model of syntax, we can best account for the similarities between tensed clauses, infinitival clauses, genitive NPs, APs with *of*-insertion, and small clauses.

In response, Williams (1983) allows that subjects are structurally defined, but denies Stowell’s definition. Instead, he argues that all subjects are external arguments – external to the phrase they are predicated of – and proposes the “admittedly ad hoc stipulation” that “only VP appears in the underlined position in the base rule for S:  $S \rightarrow NP \underline{\quad}$ ,” and claims that small clauses do not form constituents by themselves, binary-branching or otherwise. Specifically, he gives the structure in Figure 2.2 to the sentence *John considers Bill sick*:

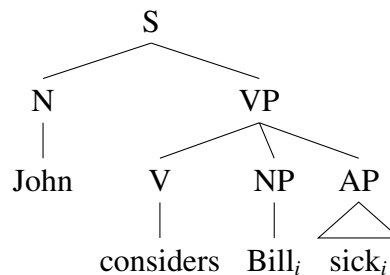

Figure 2.2: Ternary-branching predication structure

This structure notably includes a ternary-branching VP. *Consider* subcategorizes for two complements, an NP direct object and an XP predicate which at PS will be co-indexed with the nearest c-commanding NP.<sup>5</sup>

Williams discounts Constituency for several reasons, most of them having to do with principles of government and binding that are no longer relevant in any current model of syntax. But one piece of evidence conceivably is relevant: it is well-known that quantified ECM raising constructions permit two scope readings, so the sentence

<sup>5</sup>\**John<sub>i</sub> [considers sick<sub>i</sub>]*, is ruled out because one of the required complements of *consider* is missing.

*someone seems t to be sick* can mean either (a)  $\exists x$  (seems (x sick)) (*There is a person x such that it seems that x is sick*), or (b) seems ( $\exists x$  (x sick)) (*It seems that there is a person x such that x is sick*). In contrast, Williams argues, the corresponding ‘small clause’ sentence, *someone seems t sick*, has only a single scope reading:  $\exists x$  (seems (x sick)). Under Constituency, we must assign the following structure to this sentence:<sup>6</sup>

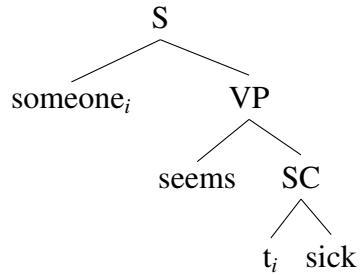

Figure 2.3: Raising verb taking a small clause complement

Because *someone* is coindexed with a trace inside the VP, we should be able to get an inverse scope reading, and we don’t. Predication can account for this variance, Williams argues, because there is no trace in the VP that would allow an inverse scope reading:

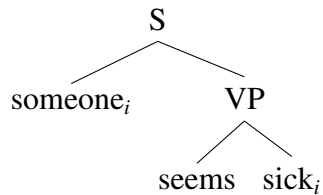

Figure 2.4: ‘Someone seems sick’ under Predication

However, some English speakers (though not all) get two scope readings for the sentence *someone seems sick* – a reading in which *someone* refers to a specific person, and the inverse reading in which *someone* does not refer to a specific person.  $\exists x.\exists w\backslash x$

<sup>6</sup>I use the category label ‘SC’ for the small clause constituent because I wish at present to remain ambiguous about the category of small clauses. Williams (1983) uses only the label ‘X’, acknowledging that other research may propose various category labels for the constituent, but he maintains that no category label can explain this scope behavior.

*is sick in w* means that a particular person seems sick, and the speaker knows who it is. This would apply to a situation like the following: in class, Mrs. Smith notices that Jane is sniffing. In the teacher’s lounge during lunch, Mr. Jones asks Mrs. Smith how the kids in her class are doing, and Mrs. Smith replies, “Fine. Most of them are paying attention. A few are particularly fidgety today. And someone seems sick.” In contrast,  $\exists w.\exists x|in\ w, x\ is\ sick$  means that in a given thought-world, a person seems sick, and the speaker doesn’t know who it is. This would apply in a situation like the following: while Mrs. Smith is writing on the blackboard, she hears a snuffle, and a voice whispers, “Here, have a tissue.” Mrs. Smith thinks, “Hmm, someone seems sick. I’d better remind everyone to wash their hands often.” It is clear that Williams’s characterization of scope readings requires further consideration, and therefore is not sufficient evidence for a ternary-branching VP model.<sup>7</sup>

Further, small clauses cannot be part of a ternary branching VP for the simple reason that not all small clauses occur in the context necessary for Williams’s analysis:

- (12) a. With [Charlie Cowell intent on ruining him], Harold wasn’t safe  
 b. [Tommy and Zaneeta in a relationship] wasn’t/\*weren’t good for Mayor Shinn’s blood pressure  
 c. Eulalie considered [[Tommy and Zaneeta in a relationship] bad for Mayor Shinn’s blood pressure]

First, small clauses may be complements to a preposition, as in (12-a). Williams would need to extend ternary-branching to PPs, a position he explicitly avoids – for Williams, only VP may be ternary-branching. Second, small clauses may be subjects, as in (12-b).

<sup>7</sup>It is also worth pointing out that Williams assumes a particular, movement-based QR model of quantification; after all it neatly explains a hypothetical lack of a scope reading. But there is no *a priori* reason to rely on *any* model of quantification to justify his argument, as it has no bearing on Predication.

Here it is important to point out that the coordinated phrase *Tommy and Zaneeta* cannot be the subject of the main clause because it does not agree with the main verb *wasn't*. English does require subject-verb agreement, however, which means that the subject of (12-b) must be singular. Note its similarity to other subjects widely understood to be clausal, which are also treated as singular: [*That Tommy and Zaneeta were in a relationship*] *wasn't good for Mayor Shinn's blood pressure*. Third, there is no restriction on where small clauses may themselves be subjects. In (12-c), *Tommy and Zaneeta in a relationship* is the subject of another small clause. Even under a ternary-branching model, that phrase is a daughter of VP; i.e. a constituent:

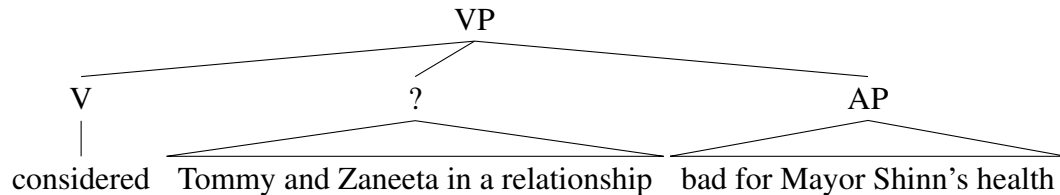

Figure 2.5: Ternary-branching means not all small clauses can share the same structure.

The sentence in (12-c) identifies a particularly problematic failure of Williams's model. He explicitly argues that small clauses are never constituents but rather comprise multiple branches of a ternary-branching structure. But as we see in Figure 2.5, one small clause must be a constituent according to his model. There is simply no reason to assume that some small clauses are constituents while others are not. Williams himself would not espouse such a dichotomy.

Predication requires that we add various machinery – a separate stage of derivation in which we co-index subjects and predicates – introduce ternary-branching when we do not otherwise need it, and make ad hoc stipulations. Constituency does not require any of these things. Rather, it makes the model of syntax more symmetric by eliminating stipulations about what categories can and cannot have specifier positions and, therefore,

subjects. It captures facts about the distribution of small clauses. And it preserves binary-branching. Additionally, the only piece of evidence Williams gives that could weaken Constituency is based on a poor semantic judgement. Ultimately, Constituency is a superior model to Predication, and the remainder of this thesis shall be concerned with fine-tuning the Constituency model.

## 2.2 The category of small clauses

### 2.2.1 Small clauses are S

Once the Constituency model of small clauses was accepted into standard syntactic theory, the question became, what category are small clauses? Stowell (1981, 1983), Contreras (1987), and others argue that a small clause is the maximal projection of its head predicate – category XP.

In contrast, Chomsky (1981), Hornstein and Lightfoot (1984, 1987) and others argue that small clauses must be bigger than maximal XP projections. Chomsky (1981) claims that they are category S to maintain uniformity of clauses: all propositional clauses are category S,<sup>8</sup> which, within the GB framework, ensured that the subject of small clauses would be governed and Case-marked as necessary from outside the small clause.

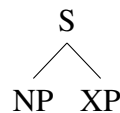

Figure 2.6: Small clause as category S

---

<sup>8</sup>not a maximal projection in the contemporary GB framework.

Hornstein and Lightfoot (1984, 1987) agree with this analysis for several reasons, the most important related to subcategorization and internal structure of the small clause. Stowell's XP model relies on the C-selection properties of matrix verbs. *Consider*, for example, selects AP but not PP, whereas *expect* selects PP and NP but not AP or NP:

- (13) a. I consider/\*expect him [<sub>AP</sub> honest]  
b. I expect/\*consider him [<sub>PP</sub> off my ship by midnight]  
c. I consider/\*expect him [<sub>NP</sub> a good teacher]

However, these selection restrictions overgeneralize. We can easily construct grammatical sentences in which *consider* selects PP and *expect* selects AP:

- (14) a. I consider/\*expect him [<sub>PP</sub> out of his mind]  
b. I expect/\*consider the books [<sub>AP</sub> shelved by this afternoon]

A perhaps larger problem with Stowell's subcategorization frames is that *expect* never subcategorizes for a small clause of category NP – but it freely takes non-small-clause NP complements, as in *I expected that result*. Hornstein and Lightfoot offer no explanation for why this should be so, but point out that subcategorization frames alone fail to explain this pattern.

Additionally, Hornstein and Lightfoot point out sentences like (13-c), such as the following:

- (15) a. I consider John [<sub>NP</sub> a friend]  
b. I consider John [<sub>NP</sub> Bill's best friend in New York]

The problem here is that the predicate in each case is a fully articulated NP with a filled specifier position – it is unclear where the ‘subject’ of the NP small clause would go in the phrasal projection, unless we assume that NP has multiple specifier positions or that a fully articulated NP can project a higher NP in which the predicate NP is the sister of its subject. In both cases, we lose symmetry because NP behaves differently than other categories – in the former case, only NP projects multiple specifiers; in the latter, only NP allows adjoined subjects.

Ultimately, Hornstein and Lightfoot, following Chomsky, agree that Stowell is right to treat small clauses as constituents, but that his definition of ‘subject’ is incorrect. Specifically, they return to the earlier proposal that only NP and S may have subject positions. Because the predicate of a small clause may be a full NP with a determiner subject, small clauses with NP predicates must not be of category NP; and by process of elimination, they must be category S.

### 2.2.2 Small clauses are S’

Kitagawa (1985) also argues that SCs must be bigger than the maximal XP projections of Stowell (1981, 1983), again pointing to subcategorization as a problem, but he takes a different approach than Hornstein and Lightfoot. Kitagawa argues that the selection restrictions of matrix verbs seem to be not on the lexical category of their complements, but rather on the complements’ aktionsarten. *Consider* selects ‘state of being’ complements, and *expect* selects ‘change of state’ complements.<sup>9</sup>

---

<sup>9</sup>A drawback Kitagawa does not address is that *expect* apparently can never take a small clause complement with an NP predicate, even when the predicate describes a change of state.



Additionally, in general only maximal projections undergo movement. If Stowell is correct that SCs are APs, NPs, etc., then WH-movement should be blocked in the following sentences because they require movement of a non-maximal projection<sup>10</sup>:

- (16) a. [AP How talented]<sub>i</sub> do you consider [SC him t<sub>i</sub>]?  
 b. [NP How good a lawyer]<sub>i</sub> did he consider [SC his son t<sub>i</sub>]?  
 c. The police busted up the party, was it fair? [PP Just how off the hook]<sub>i</sub> did you consider [SC it t<sub>i</sub>]?

But these sentences are perfectly grammatical.

Moreover, in non-pro-drop languages such as English and French, all sentences must have overt subjects, which may be realized as semantically vacuous expletive pronouns:

- (17) a. *It* is unlikely that Eulalie and Marian could be friends  
 b. *Il y a* un chat dans la voiture (French)  
 It has there a cat in the car  
 “There is a cat in the car”

NPs, on the other hand, don't allow expletive subjects (18-a). If SCs containing nominal predicates are NPs (per Stowell), then SCs should not have expletive subjects. But expletive subjects are in fact obligatory in SCs (18-b):

- (18) a. \*it unlikeliness that Eulalie and Marian will be friends  
 b. Mayor Shinn considers \*(it) an absurdity to suggest that Eulalie and Marian could be friends

---

<sup>10</sup>I adopt his category labels here, including SC for small clauses.

Based on sentences like those in (14), (16) and (18-b), Kitagawa concludes that Stowell's analysis must be incorrect: SCs should not be analyzed as predicate phrases of category NP, AP, etc., but instead as larger constituents that may contain maximal projections such as NP.

How much larger? Expletive subjects are licensed by an EPP feature in the T head. Consequently, according to Kitagawa SCs must minimally contain INFL (=T).<sup>11</sup> Further, SCs must contain COMP (=C) to allow for extraction out of the small clause. Consider the following sentences:

- (19) a. Who<sub>i</sub> did Marcellus think [<sub>S</sub>' t<sub>i</sub> [<sub>S</sub> t<sub>i</sub> [<sub>INFL</sub> a great con man]]]?  
 b. \*Who<sub>i</sub> did Marcellus consider [<sub>S</sub>' that [<sub>S</sub> t<sub>i</sub> [<sub>INFL</sub> a great con man]]]?

Under GB, we can account for the asymmetry between (19-a) and (19-b) by appealing to either a Doubly Filled COMP Filter (Chomsky and Lasnik, 1977) or, if we assume doubly-articulated CP and IP with spec, head and complement positions, a Barriers-style model of subjacency (Chomsky, 1986). Because extraction out of SCs yields grammatical sentences, Kitagawa assigns them a structure identical to that of (19-a), and concludes that SCs are category S' (=CP):

- (20) a. Who<sub>i</sub> did Marcellus consider [<sub>S</sub>' t<sub>i</sub> [<sub>S</sub> t<sub>i</sub> [<sub>INFL</sub>  $\emptyset$  [<sub>NP</sub> a great con man]]]]?]

There is no particular reason that small clauses must be big in order to account for this data, however; there are other solutions that do not necessitate large small clauses. Remnant movement is one such possibility. If the subject is extracted from the small

---

<sup>11</sup>He claims that in SCs, the head of INFL is a phonetically null copula, and he justifies this with evidence from Japanese; this is not central to his argument.

clause first, for example via raising-to-object, then the entire remnant small clause raises to initial position for questions. This derivation accounts for Kitagawa's sentences but makes no assumptions about the internal structure of small clauses. This thesis takes no position regarding the syntax of questions and relative clauses and consequently remains agnostic about sentences such as Kitagawa's; however it is important to note that there are ways to account for Kitagawa's data other than postulating that small clauses are actually quite large.

### 2.2.3 Small clauses are PrP

But syntactic theory evolved, eventually introducing strict binary-branching (Kayne, 1984),<sup>12</sup> doubly-articulated CP and IP (later TP) (Chomsky 1986), a deeper interest in argument structure (e.g. Larson's (1988) nested VPs for double-object constructions, and Koopman and Sportiche's (1991) VP-internal subject hypothesis), and a wider range of functional projections (e.g. Pollock's (1989) AgrP, which accounts for cross-linguistic variation in adverb placement). As the function of IP/TP was fleshed out – specifically, it is the locus of tense inflection – it is natural that we should assign IP/TP as the category of main clause sentences, embedded infinitival clauses, and tensed complements contained within CP. But it is less clear that this should be the category of small clauses, which are specifically not tensed. Consequently, the widely held view that small clauses are category S (or S', in the case of Kitagawa) must be brought into question, but given the existence of small clauses with fully articulated NP predicates, they must be larger than NP – and for uniformity across small clause types, larger than AP, PP and VP.<sup>13</sup>

---

<sup>12</sup>Although strict binary branching would not be widely adopted until Chomsky's (1994) Bare Phrase Structure.

<sup>13</sup>To the best of my knowledge, the first proposal that small clauses are 'larger' than Stowell's XP but 'smaller' than IP/TP was made by Chung and McCloskey (1987). See Chapter 3.

Adopting one of the strengths of Williams’s Predication theory, namely that small clauses and ‘regular-sized’ clauses are both instances of the same kind of subject-predicate relationship and that a good model of syntax should capture this, Bowers (1993) proposes a new functional category, the predication phrase (PrP), whose semantic function is predication.<sup>14</sup> Predicates of all categories project PrP. The head of PrP has an EPP feature which guarantees that the spec-PrP will be filled. The functional head mediates the relationship between its specifier – the subject – and its complement – the predicate:

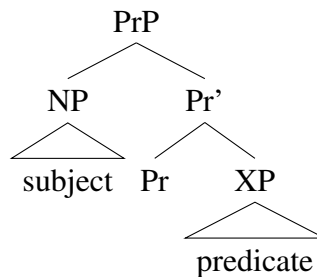

Figure 2.7: The structure of PrP

Thus, under Bowers’s model, the sentence *Harold will lead the band* will have the following structure:<sup>15</sup>

---

<sup>14</sup>A functional category serving the same purpose was independently proposed by Rafel (1998), but he does not assign a name to the category, preferring instead to call it ‘FP’ for ‘functional phrase’. Others assign different names to the same category, such as  $\pi$ P (Citko, 2008). Still others propose categories that are merely similar, such as iP (Matushansky, 2006). I shall continue to refer to the category as PrP.

<sup>15</sup>Bowers (1993), although Minimalist in spirit, was published before the onset of Minimalism and Bare Phrase Structure, and he incorporates unary branching into some of his diagrams. Because it does not affect his proposal, and because PrP is still useful for my purposes within a Minimalist framework, I have eliminated unary branching from this and other trees within this section.

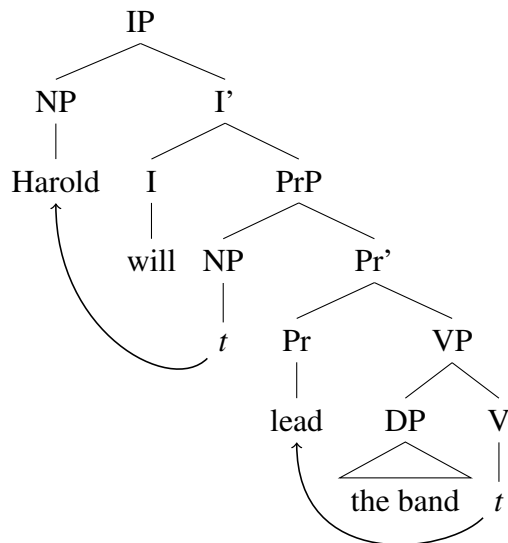

Figure 2.8: The structure of a tensed clause

The verb, *lead*, projects VP whose specifier position will be filled with a direct object, *the band*.<sup>16</sup> As a predicate, VP then projects PrP, whose specifier will be filled with the external argument (subject), *John*. As this is a ‘regular-sized’ clause, PrP projects IP, whose head is filled with tense morphology (*will*). English word order is achieved by raising the external argument to spec-IP via spec-to-spec movement, and raising the verb to the Pr head via head-to-head movement. Strict cyclicity demands that all elements that move to TP must first move through PrP.

A more complex example is *Harold might consider Marian attractive* where the matrix verb *consider* takes the small clause complement *Marian attractive*:<sup>17</sup>

<sup>16</sup>See Bowers (1993) and Lasnik (1995) for justification of spec-VP as the site where direct objects are generated.

<sup>17</sup>The phrase structure diagram shown here omits raising-to-object. Bowers (1993) and Lasnik (1995) argue that direct objects are generated in spec-VP rather than as complements to the verb. Further, they argue that the subject of a small clause, i.e. the specifier of the embedded PrP, raises to the matrix object position. The syntactic behavior of objects, including site of Merge, is inconsequential for my argument. For simplicity, I depict objects as base-generated as complements to V, and omit raising-to-object.

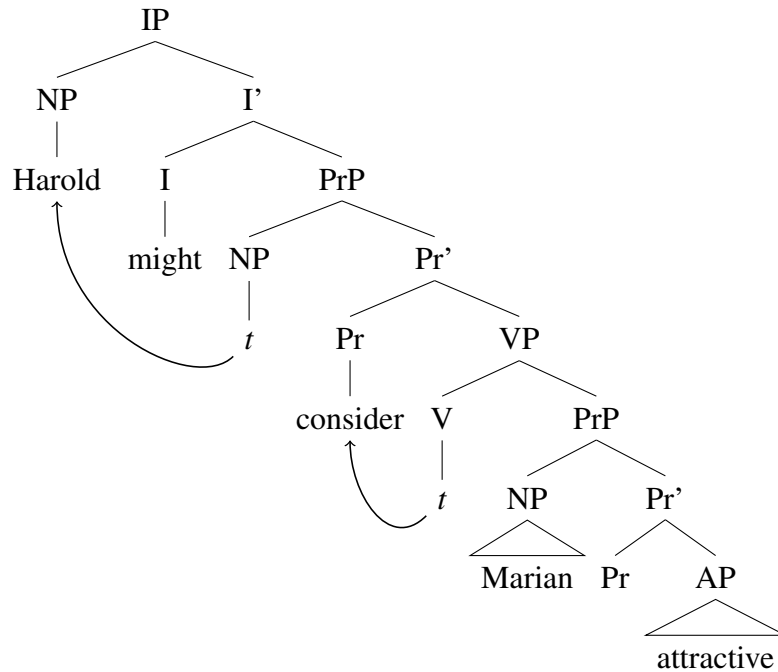

Figure 2.9: *Consider* takes a small clause complement.

Here, the predicate is an adjective which will project AP. As a predicate, it will project PrP, where *Marian*, the external argument, will merge in spec-PrP. *Attractive* moves to Pr via head-to-head movement. *Mary* merges in spec-PrP to satisfy Pr's EPP feature. The selection properties of the matrix verb *consider* specify that it can take a PrP complement. Thereafter the derivation proceeds as in the previous example: the verb, *consider*, projects VP, then because it is a predicate it projects PrP. The external argument, *Harold*, merges in spec-PrP. PrP projects IP, whose head is filled with tense and inflection. An EPP feature in I requires that the external argument, *Harold*, move into spec-IP. *Consider* moves from V to P via head-to-head movement.

The strength of Bowers's theory is that it capitalizes on the advantages of each theory previously discussed. Like Williams (1980, 1983), he recognizes the similarity of the predicate-subject relationship in 'regular-sized' and small clauses and makes trans-

parent the relationship between the syntax and semantics of predication. Like Stowell (1981, 1983) he argues that all lexical categories can be predicates with subjects, and provides a uniform structural definition of ‘subject’. Like Chomsky (1981), Hornstein and Lightfoot (1984, 1987) and Kitagawa (1985), he argues that all subject-predicate structures should be of the same category.

Additionally, there are further advantages that the previous theories cannot capture. It accounts for coordination facts, as in the following sentence:

(21) Mayor Shinn considers Eulalie [<sub>A</sub> talented] and [<sub>NP</sub> a tyrant]

It is widely held that only like categories can be coordinated. The introduction of PrP neatly accounts for (21):

(22) Mayor Shinn considers [<sub>PrP</sub> Eulalie [<sub>Pr</sub> P [<sub>AP</sub> talented]] and [<sub>Pr</sub> P [<sub>NP</sub> a tyrant]]]

Another particularly valuable result of Bowers’s model is that it captures typological differences in predication. It is well known that in Chinese, main clause sentences can feature an NP subject and AP predicate without a copular verb; some speakers also accept NP predicates, especially in colloquial contexts:

- (23) a. Ta hen mang  
He very busy  
“He is (very) busy”  
b. Zhangsan tiancai  
John genius  
“John is a genius”

Similarly, Gair and Paolillo (1998) show that in Sinhala, AP, NP and PP can all be main clause predicates without copular verbs:

- (24) a. ee potə bohoma alut  
 that book very new  
 “That book is new”
- b. gunəsiri mahattəya apee iskoole mul guruwəyəya  
 Gunasiri Gentleman our school head teacher  
 “Mr. Gunasiri is the head teacher of/in our school”
- c. ee potə apee kaaməree tiyenə meese uḍə  
 that book our room-LOC be-REL table upon  
 “That book is on the table which is in our room”

Baker and Vinokurova (2009) present data from Sakha showing that AP and NP can be main clause predicates, no verb necessary:<sup>18</sup>

- (25) a. bihigi bytaam-myt  
 we slow-1.PL.S  
 “We are slow”
- b. bihigi balyksyt-tar-byt  
 we fishermen-PL-1.PL.S  
 “We are fishermen”

We can now easily account for these differences. In Chinese and Sakha, TP can select PrP complements with AP and NP predicates; in Sinhala, TP can select PrP complements with AP, NP and PP predicates. In English, however, TP can only select PrP complements with VP predicates; thus, only clauses with verbal predicates can be main clauses.<sup>19</sup>

<sup>18</sup>In these glosses, ‘S’ stands for ‘predicative’, with subject-predicate agreement.

<sup>19</sup>One possibility for such a restriction is that English requires a verb to carry tense morphology, and AP, NP and PP predicates lack a verb that would carry this morphology. A natural question is, why wouldn’t the expletive tense marker *do* be available in this situation, such that *Mary does attractive* would be the main clause equivalent of the small clause *Mary attractive*? According to Chomsky (1995), *do*-insertion operates as a last resort. The availability of the copular verb *be*, which I argue in Chapter 4 is a



Further, although the subject-predicate relationship is now systematic and uniform in the syntax, we preserve the fundamental difference between ‘regular-sized’ clauses and small clauses: tense. Full clauses project IP/TP and are [+/- tense]; small clauses do not project IP/TP and do not have tense. By separating predication from tense syntactically, we ensure that all predicates predicate, but only full clauses have tense.

This advantage is especially apparent when we compare a set of sentences with raising verbs:

- (26)
- a. It seemed (that) Harold was honest
  - b. It seems (that) Harold will be honest
  - c. It will seem (that) Harold was honest
  - d. Harold seems honest
  - e. Harold seemed honest

*Seem* is a prototypical raising predicate. Its complement is clausal – i.e. the complement contains a subject and a predicate. In (a)-(c) above, the complement contains a tensed TP and the subject of the embedded clause is assigned Nominative Case by the embedded T head. Expletive *it* satisfies the EPP feature of the matrix T head. Notably, the tense of the matrix TP and the tense of the embedded TP need not match. In (26-b), the matrix TP is [+present] while the embedded TP is [+future]; and in (26-c), the matrix TP is [+future] while the embedded TP is [+past]. When the sentence contains two tensed TPs, there is no syntactic reason the tenses of each clause must match.<sup>20</sup>

---

raising verb, makes *do*-insertion unnecessary: according to Chomsky, Move is preferred.

<sup>20</sup>However, when the matrix verb is past-tense, pragmatic facts make tense mismatch less well-formed. Note the oddity of *It seemed that Harold is honest*. I attribute this to speaker knowledge about the interaction of past and current events.

In contrast, tense mismatch is impossible in the (d)-(e) examples above. The simple solution is that *Harold seems honest* contains only one TP – the matrix TP – whereas the complement clause, *Harold honest*, is a PrP that is by definition untensed. If the complement clause is a TP, we must devise an additional structural mechanism that prevents tense mismatch or, worse, stipulate that small clauses, although TPs, are tenseless. Such a mechanism or stipulation is unnecessary if the complement clause is a PrP instead. Under Minimalism, we derive the sentence as follows. Structurally, *Harold* must Move to spec-TP to be assigned (Nominative) Case and satisfy T’s EPP feature:<sup>21</sup>

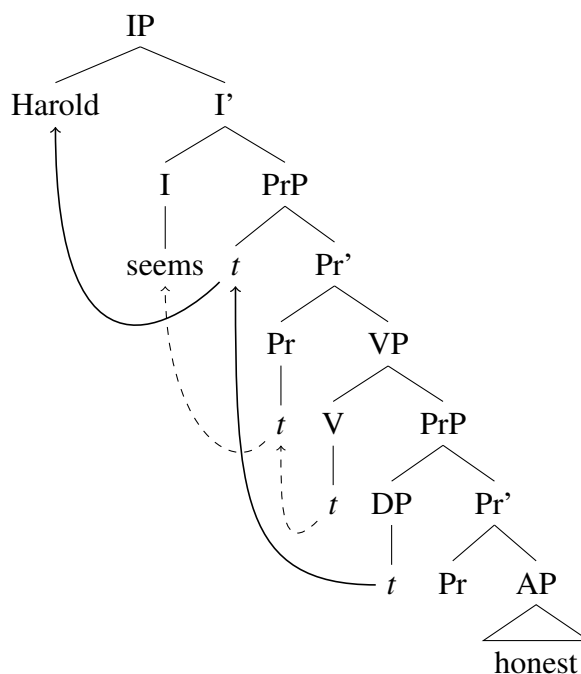

Figure 2.10: Raising verbs take small clause complements

Raising predicates take clausal complements, but different verbs have different selection restrictions. In English, *seem*, *appear* and *likely* always take clausal complements,

<sup>21</sup>Throughout this thesis I depict verbs moving from V to Pr to I/T. Much literature is concerned with the question of whether V moves to I in all languages or only some. For example, Pollock (1989) argues that in French, V always raises to I, but that in English, V raises to AgrO and stays there. Similarly, Bowers (1993) argues that in French, V raises first to Pr then to I, whereas in English, V raises to Pr and stays there. I direct the reader to these sources for discussion.

but the size of the complement (PrP or larger than PrP) can vary. The below examples show a tensed CP or IP/TP complement, an infinitival IP/TP complement, and a tenseless PrP complement:

- (27)
- a. It seems/appears/is likely (that) Harold is honest
  - b. Harold seems/appears/is likely to be honest
  - c. Harold seems/appears/is likely honest

However, different raising predicates have different selection restrictions. *Happen* takes CP and IP/TP but not PrP complements, whereas *become* only takes PrP complements:

- (28)
- a. It happened that Harold was dishonest
  - b. Harold happened to be dishonest
  - c. \*Harold happened dishonest
  - d. \*It became that Harold was honest
  - e. \*Harold became to be honest
  - f. Harold became honest

These selection restrictions also vary cross-linguistically. For example, Attia (2005) reports that in Arabic, *šbaḥa* ('become') can take both IP/TP and PrP complements, whereas *yabdu* ('seem') can take only PrP complements:

- (29)
- a. *šbaḥa l-waladu sa'īdan*  
became the-boy happy  
"The boy became happy"
  - b. *šbaḥa l-waladu yuḥibbu l-qira'ata*  
became the-boy to-like the-reading  
"The boy became to like to read"

- c. yabdu l-waladu sa'idan  
seems the-boy happy  
“The boy seems happy”

I mentioned previously that the term ‘small clause’ is typically used to refer to [NP XP] constructs, where XP is NP, PP or AP. This kind of stipulation is typical in small clause research within the P&P and Minimalist frameworks, and there has been little work investigating the possibility of verbal small clauses or explicitly arguing that they do not exist.

Given the PrP model, in which all clauses with subjects contain PrP and any category may project PrP, we would expect to see verbal small clauses. Without contradictory evidence, it is reasonable to question whether the complements of causative and sensory verbs fill the gap. Consider the following:

- (30) a. Marian made [Harold (\*to) leave the library]  
b. Amaryllis heard [Winthrop (\*to) lisp ]

Note that the subject bears Accusative Case, which must be assigned from within the matrix clause; and that the infinitival tense marker is impossible, despite it being necessary in a sentence identical in meaning to (30-a):

- (31) Marian caused [Harold \*(to) leave the library]

*Cause* and *make* are synonymous causative verbs. The only difference between them is that *cause* takes an infinitival TP complement and *make* does not. The complement of *make* has a subject and a predicate, which means that it contains at minimum a PrP.

These verbs are not unique. The verbs *let* and *allow* have the same pattern:

- (32) a. Marian let [Charlie Cowell (\*to) woo her]  
b. Marian allowed [Charlie Cowell \*(to) woo her]

However, if verbs like *cause* and *allow* can take PrP complements with VP predicates, we might also expect raising verbs like *seem* to take PrP complements with VP predicates, but the resulting sentences are impossible:

- (33) a. \*Amaryllis seemed play the piano  
b. \*Harold appeared sell band instruments

It may be that verbs have features that must be checked by a functional head higher than PrP, which would mean that small clauses cannot have VP predicates, and the complements to *cause*-class verbs are not PrPs. At present, the category of VP complements remains an unresolved problem.

Given that the primary function of Pr is to mediate between a subject and a predicate, a natural question is whether clauses without subjects (i.e. those with unaccusatives and raising verbs) contain PrP. For example, the subject of a raising verb could move directly from within the embedded clause to the matrix clause's spec-TP, with the correct word order as a result:

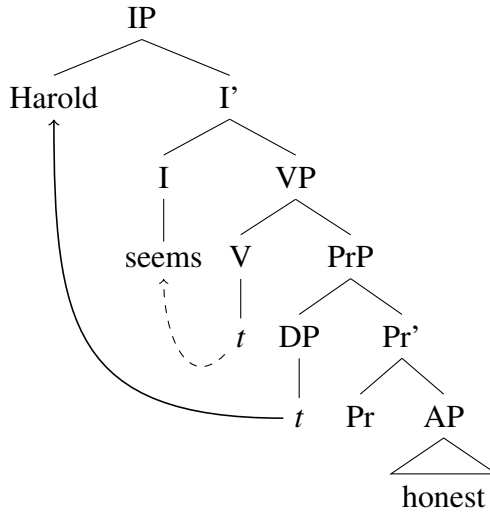

Figure 2.11: Raising verb without matrix PrP

Compare this with Figure 2.10, in which I depicted the raising verb *seem* as projecting PrP. But is there evidence that it does?

Evidence that raising verbs do in fact project PrP is found in sentences containing expletive subjects:

- (34) a. It seems that Marian likes cherry phosphate  
 b. It appears (that) Harold is a band leader

In these sentences, the embedded clause is tensed, and all arguments receive Case within the embedded clause; none of the embedded DPs are available to move into the matrix clause to satisfy  $T^0$ 's EPP feature. But all English clauses must contain a grammatical (if not a thematic) subject, and we see that these sentences contain the expletive subject *it* to fulfill this requirement. I have said that Pr mediates between a subject and a predicate and that lexical subjects are base-generated in spec-PrP; by extension, lexical subjects are not base-generated in spec-TP. Bowers (2002) cites evidence that expletive

subjects, similar to lexical subjects, are generated in spec-PrP. First, if they Merge directly in spec-TP, nothing prevents a sentence like *There will someone eat a bagel*, *It seems Harold honest*, or *It Harold seems honest*, in which the probe in T assigns Case to the lexical subject which has raised to spec-PrP, but T's EPP feature is satisfied by an expletive subject Merging directly in T. However, these sentences are impossible. Following Chomsky (1981), Bowers argues that expletives are “quasi-arguments” and therefore cannot Merge directly in a pure non- $\theta$  position like T. PrP, however, which does not contain a probe or  $\phi$ -features, is not a pure non- $\theta$  position, which means that subjects – even expletive subjects, as “quasi-arguments” – Merge there directly. Therefore, the correct structure for *Harold seems honest* is in Figure 2.10. Per Bowers, any argument that Moves to or through spec-TP must first Move through or Merge at spec-PrP. For details, see Bowers (2002).

The same question may be asked of unaccusatives: do they project PrP? Without PrP, we can generate the correct word order for *The con man arrived* if *the con man* Moves directly into spec-TP. However, in order to generate the correct word order for *There could arise a serious misunderstanding*, *arrived* must raise out of V – as argued by Bowers (1993) and Lasnik (1995), underlying direct objects are generated in spec-VP, which gives the underlying order [*a serious misunderstanding*] *arise*. If *arise* does not raise, we get the ungrammatical word order *\*There could a serious misunderstanding arise*. The verb cannot raise to T, which is occupied by *could*. Instead, it raises to Pr, and the expletive subject Merges in spec-PrP, as discussed above for raising verbs (see Bowers (2002) for details). It will then move to spec-TP to satisfy T<sup>0</sup>'s EPP feature. The correct structure for unaccusatives contains PrP. As with raising verbs, a lexical DP Moves there, or an expletive subject is generated there. The correct structure for *Iowans saw the con man arrive* is as follows:

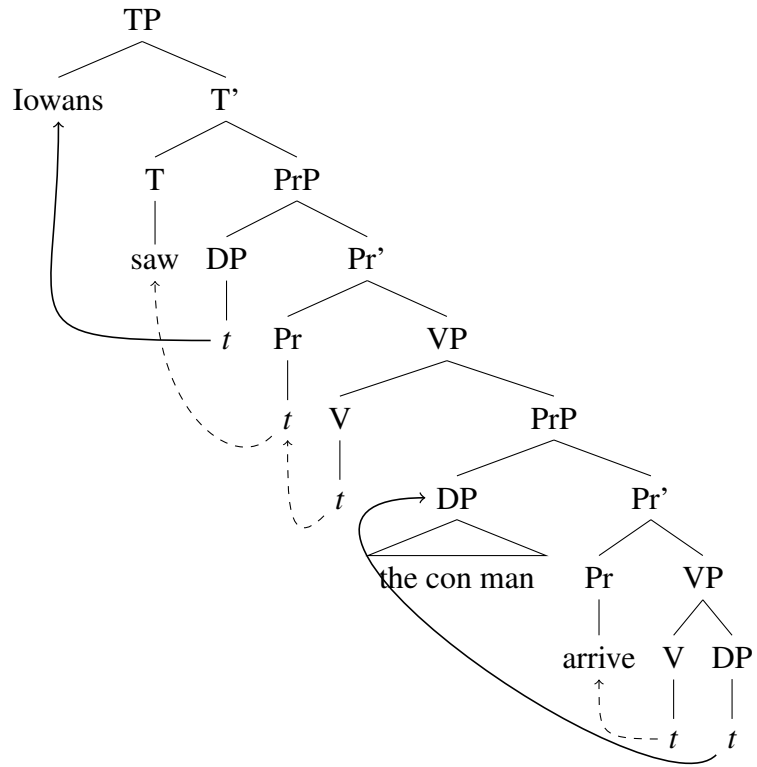

Figure 2.12: Unaccusatives do project PrP

To sum up thus far, all clauses project PrP, even those that don't have thematic subjects. Subjects are generated in or move to spec-PrP. All subjects that move to spec-TP must first move through spec-PrP. Small clauses are PrPs with an XP complement. Tensed clauses (including infinitival clauses) are TPs with a PrP complement. English requires that main clause predicates must be VPs, although this is not universal. This section has been primarily concerned with the structure of clauses. In the next section, I will discuss the Pr head in more detail.



## 2.3 The predicator head

My description of the head of Pr has thus far been rather vague – it predicates; it mediates the relationship between a predicate and its subject; it provides a structural position where subjects can be generated. Assuming there is a predicator head in English contributes to a more parsimonious model of clause structure, but the argument would be strengthened with evidence of a phonetically overt Pr head. Bailyn (2001a,b) argues that just such evidence can be found in Russian and other languages, and refers to these heads as Overt Predicators.

First, consider the following Russian sentences:

- (35) a. My sčitaem ego svoim/ \*svoego  
We consider him.ACC self's.INSTR/ \*self's.ACC  
“We consider him one of us”
- b. my tancevali p'janyimi/ \*p'janye  
We danced drunk.INSTR/ \*drunk.NOM  
“We danced drunk”
- c. On vygljadit durakom/ \*durak  
he-Nom looks fool.INSTR/ \*fool.NOM  
“He looks (like) a fool”

In each of these examples, a predicate must exhibit instrumental case: in (35-a) it is the predicate of a small clause complement; in (35-b) it is a depictive predicate, and in (35-c) it is in a raising construction. Bailyn argues that in Russian, Pr has strong inherent case features, so that the predicate must surface with instrumental case.<sup>22</sup> The Pr head is phonetically null. With the exception of instrumental case marking, this is no different from the situation in English.

---

<sup>22</sup>Matushansky (2006) refers to this functional head as ‘i(nstrumental)’ to distinguish predication from instrumental-marking, essential in her view because there are instances of predication without instrumental case. For simplicity I shall continue to refer to it as Pr.

However, Bailyn points out that in Russian not all predicates surface with instrumental case – the inclusion of the word *kak* necessarily prevents predicates from exhibiting instrumental case. Sentences corresponding to those in (35) follow:

- (36) a. My sčitaem ego kak svoego/ \*svoim  
 We consider him-Acc self's.ACC/ \*self's.INSTR  
 “We consider him one of us”
- b. my tancevali kak p'janye/ \*p'janymi  
 We danced drunk.NOM/ \*drunk.INSTR  
 “We danced drunk”
- c. On vygljadit kak durak \*durakom  
 he looks fool.NOM/ \*fool.INSTR  
 “He looks (like) a fool”

In Russian, constructions with *kak* never show instrumental case on the predicate. Bailyn argues that *kak* is a phonetically overt realization of the Pr head, with different properties than its null counterpart; and that an overt Pr head absorbs instrumental case. He extends this to a more general universal: overt predicators absorb case.<sup>23</sup> The ungrammatical variants in (36) crash because the inherent instrumental case of the predicates cannot be checked by the now-caseless Pr head; instead, the predicate's case matches that of its subject. In contrast, movement and multiple specifier positions at LF allow assignment of weak structural Case to the predicate. At LF, (36-a) thus has the following structure:

---

<sup>23</sup>Stated in universal terms, this explanation is complementary not only with the specific implementation of functional-head predication espoused by Bowers (1993, 2001) and Bailyn, but with variations of the model such as that of Matushansky (2006).

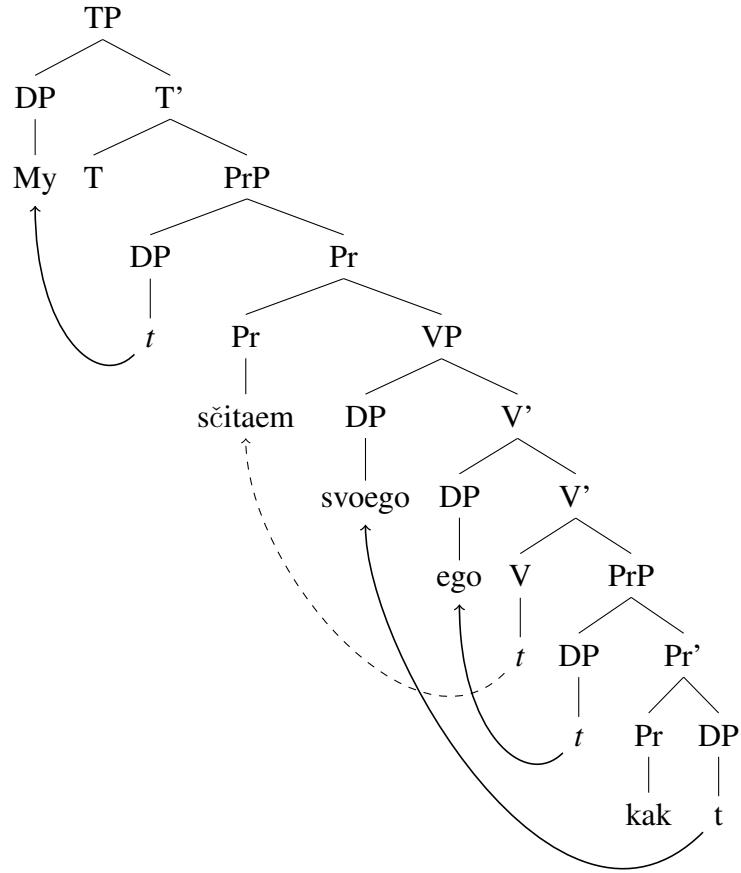

Figure 2.13: Russian at LF

Russian *kak* is perhaps not an isolated artifact. Another Russian word, *za*, also appears to function as an overt predicator – i.e. driving case absorption and preventing instrumental-marking. Traditionally, it is analyzed as a preposition, but it would be unique among Slavic prepositions in taking a Nominative complement; whereas if we treat it as an overt predicator, the case facts fall out:

- (37) a. Myščitaem ego za svoego  
 We consider him.ACC PR self's.ACC  
 “We consider him one of us”

- b. Cto èto za pesnja?  
 “What this PR song.NOM  
 “What kind of song is this?”

Additionally, the phenomenon of overt predicators is not unique to Russian. Other researchers, citing Russian as an exemplar, frequently label particles in various languages overt predicators. A non-exhaustive list includes Welsh, Scottish Gaelic, Edo, Chichewa, Swedish, Norwegian, German, and English.

The relevant Welsh word is *yn*. Borsley (1986, 1989, 1999) glosses Welsh *yn* as a preposition in all contexts but notes that in this context it does not behave in the typical manner of prepositional *yn*, which triggers nasal mutation (plosives become nasals). In the Welsh example above, *yn* triggers lenition instead (e.g. voiceless plosives become voiced plosives, among other changes). Like Borsley, Gensler (2002) glosses *yn* in all contexts as a preposition, but he acknowledges that it has distinct functions, as we see below:

(38) Welsh

- a. mae Siôn \*(yn) ddedwydd  
 is Siôn PR happy  
 “Siôn is happy”
- b. mae Huw yn Nulyn  
 is Hugh in Dublin  
 “Hugh is in Dublin”
- c. mae Huw yn dysgu  
 is Hugh *asp* learning  
 “Hugh is learning”
- d. mae Huw yn ddysgwr  
 is Hugh PR learner  
 “Hugh is a good learner”

In (38-b), *yn* is a locative preposition that triggers nasalization (*Dulyn* “Dublin” → *Nu-lyn*). In (38-c), *yn* is part of a periphrastic verbal aspectual construction and triggers no mutation. In (38-d) and (38-a), *yn* is predicative and triggers lenition (*d* → *dd*). *Yn* exhibits the same syntactic behavior in exactly the two contexts that are relevant for this thesis: with predicative adjectives (38-a) and nouns (38-d). Note that *yn* also appears in what appears to be a small clause context:

- (39) Gwelaf i John yn dal  
 see I John PR tall  
 “I see John as tall”

Scottish Gaelic has a particle that agrees in person and number with the predicate’s subject, in this case third-person masculine singular, but otherwise the particle has similar functionality to Welsh *yn* in the relevant contexts with predicate nominals and adjectives (Adger and Ramchand, 2003):<sup>24</sup>

- (40) Tha Calum ’na thidsear  
 is Calum PR.3.SG teacher  
 “Calum is a teacher.”

Edo has two relevant particles, *rè* and *yé*.<sup>25</sup> A predicative particle is obligatory with predicative nouns and adjectives. However, Baker (2003) argues that they are not verbs, for several reasons. Verbs in Edo vary in tone to distinguish between past and non-past;

<sup>24</sup>Analyzing the Scottish Gaelic particle as an overt predicator is controversial. Wayne Harbert (personal communication) notes that *'na* has a very different distribution than overt predicator particles in other languages. First, it does not occur with adjectival predicates. Second, it occurs with stative verbs (but not other verbs). Essentially, *'na* surfaces where we would expect a stative marker, rather than a predicational marker. Whether Scottish Gaelic has an overt predicator is ultimately not essential to the central argument of this thesis; I do not claim that all languages have overt predicators. However, it is worth pointing out that some researchers, like Adger and Ramchand, do analyze the relevant particle as an overt predicator.

<sup>25</sup>For discussion of the distribution of these particles, see Baker (2003).

*rè* and *yé* have high tone in all contexts. Additionally, verbs in Edo can be nominalized and undergo predicate cleft; *rè* and *yé* cannot. Lastly, stative verbs in Edo appear in serial verb constructions; *rè* and *yé* cannot. Because they serve a predicative function but are not verbs, Baker argues they are Pr heads.

- (41) a. Úyí \*(*rè*) ókhaèmwèn  
 Uyi PR chief  
 “Uyi is a chief.”
- b. Èmèrí \*(*yé*) mòsèmòsè  
 Mary PR beautiful  
 “Mary is beautiful”

In Chichewa, the overt predicator is the particle *ndi*. As for Edo, Baker identifies several reasons that the predicator is not a verb. For example, Chichewa verbs end with verb-final *-a*, but the particle does not. Additionally, Chichewa verbs bear rich subject- and object-agreement morphology, but *ndi* does not. For this and other reasons, Baker argues that *ndi* is a Pr head.

- (42) a. m-kango \*(*ndì*) w-a u-kali.  
 3-lion PR 3-ASSOC 3-fierce  
 “The lion is fierce.”
- b. m-kango \*(*ndì*) m-lenje  
 3-lion PR 1-hunter  
 “The lion is a hunter”

There is also a strong candidate for an overt predicator in English small clauses: Bowers (1993, 2001) suggests that *as* functions as a phonetically overt realization of the Pr head in structures like these:

- (43) a. Marcellus regarded Harold *as* talented/ a great con man/ off his rocker  
 b. Mrs. Paroo thought of Marian *as* a spinster/ stubborn/ in the pink of health  
 c. Miser Madison honored Marian *as* the River City librarian

As with *yn* in Welsh, *as* displays different syntactic behavior depending on its context. In the small clause context, it can take complements of various categories (e.g. NP, AP). In a different, equally productive context, it can take only NP complements:

- (44) a. As band leader/ \**as* talented/ \**as* in the know, Harold will save the boys of River City from moral corruption  
 b. Harold worked in River City *as* the band leader/ \**as* dishonest/ \**as* on his game

Due to this distribution, it is reasonable to distinguish between propositional *as* in (44) and predicational *as* in (43).

Additionally, Lundin (2003) argues that Swedish *som* is an overt predicator in sentences like these:

- (45) a. Jag såg honom som min bäste vän  
 I saw him PR my best friend  
 "I saw him as my best friend"  
 b. Med honom som domare skulle vi säkert inna målet  
 With him PR judge should we surely win case-the  
 "With him as judge, we should surely win the case"  
 c. Jag answer honom som min räddare  
 I consider him PR my savior  
 "I consider him my savior"

Bailyn (2001b) identifies that *za* in Polish is an overt predicator; note category- and Case-matching between the subject and predicate of the small clause:

- (46) Uwazam go za głupca  
 Consider.1.SG him.ACC PR fool.ACC  
 “I consider him a fool”

And finally, Eide and Åfarli (1999) argue that Norwegian and German have overt predicators, *som* and *als* respectively:<sup>26</sup>

(47) Norwegian

- a. Vi fant Marit \*(som) nervevrak  
 we found Mary PR nervous wreck  
 “We found Mary a nervous wreck”
- b. Vi returnerte pakken \*(som) flypost  
 we returned parcel-the PR air mail  
 “We returned the parcel via air mail”

(48) German

- a. Ich betrachte Johann \*(als) einen Idioten  
 I consider John PR an idiot  
 “I consider John an idiot”
- b. Sie charakterisiert diesen Mann als sehr dumm  
 She characterized the man PR very stupid  
 “She characterized the man as very stupid”

Some disagree with Bailyn’s analysis of overt predicators. Marelj and Matushansky (2009) argue against overt predicators in Russian – and, by extension, suggest that we should consider other analyses for the relevant functional particles in other languages.<sup>27</sup>

<sup>26</sup>Note that both *som* and *als* function as complementizers in other contexts.

<sup>27</sup>They admit that it is hard to explain Russian predicate case without positing a mediating functional head, but suggest that we should, again, look for a different analysis than that of Bowers (1993, 2001),



They propose that *kak* and *za* are a complementizer and preposition, respectively.

First, they argue that *kak* constructions have different distribution than “regular small clauses,” which are associated only with subject and object positions, exhibit the expected instrumental case, and lack overt predicators. In contrast, in the following sentences, the relevant structures are adjuncts and likely elliptical structures, and there are no restrictions on the morphological case of the NP following *kak*:

- (49) a. Ona govorit so mnoj kak s kakim-nibud' rebenkom  
 she.NOM speaks with me as with some.FC child.INSTR  
 “She speaks with me as if I were a child”
- b. Ona govorit so mnoj kak rebenok  
 she.NOM speaks with me as child.NOM  
 “She speaks with me as if she were a child”
- c. On ej vse prinosit kak princesse  
 he.NOM her.DAT everything brings as princess.DAT  
 “He brings her everything as if she were a princess”

But none of these are decisive evidence. (49-b) and (49-c) show the predicted case-matching rather than instrumental case on the predicate, while *kakim-nibud' rebenkom* in (49-a) is the complement of the preposition *s* and therefore cannot be expected to show case-matching. An alternate analysis might be that small clauses with overt Pr heads have different distributional properties than those with null Pr heads.<sup>28</sup>

They further argue that while the post-*kak* NP can be quantified (with a resulting pejorative connotation), predicates of “regular small clauses” cannot be quantified:

- (50) a. Ja čuvstviju sebja kak inostranec  
 I feel self.ACC as foreigner  
 “I feel like a foreigner”

---

Bailyn (2001a,b), and others. See Footnote (35).

<sup>28</sup>See Section 3.1 and Section 4.

- b. Ja čuvstvuj<sup>u</sup> se<sup>bja</sup> kak kakoj-nibud' inostranec  
 I feel self.ACC as some foreigner  
 "I feel like some stupid foreigner"

They don't give an example of an ungrammatical quantified small clause, so we must accept their report that such sentences are ungrammatical. However, it is not certain that (50-b) includes an instance of true quantification. In sentences like these, *some* seems to take on a non-quantificational, intensifying function. Even if it is a true quantifier, there is no universal constraint against quantified predicates in small clauses; this is obvious when we consider comparative small clauses:

- (51) a. Mayor Shinn considered the marching band less of a problem than the pool hall  
 b. Harold regarded the people of River City as some of the biggest suckers he'd ever met

Marelj and Matushansky also argue that the what follows *kak* may not form a constituent, and therefore cannot be a predicate; and that it also often introduces clausal elements:

- (52) a. Ona govorit so mnoj kak odin rebenok s drugim  
 she.NOM speaks with me as one child.NOM with other.INSTR  
 "She speaks with me like one child with another"  
 b. Ja postuplju s vami kak postupajut s malen'kimi det'mi  
 I treat.PRF with you as treat with small children  
 "I will treat you as they do small children"

In (52-a), *odin rebenok s drugim* is an ellipited/gapped structure, rather than an NP predicate. In (52-b), *postupajut s malen'kimi det'mi* is a clausal element being compared to

the matrix clause. This is the crux of their argument: here *kak* behaves as a complementizer, so it must be a complementizer in all instances, and therefore the simplest analysis of the structures at interest (those that I have described as small clauses with overt Pr heads) is to treat them as ellipted CPs.

This point relies on the faulty assumption that under the functional head model of small clauses *kak* could have only one function, as an overt predicator. However, it is well known that words can have more than one function. For example, English *that* serves three similar functions as a complementizer, demonstrative determiner, and pronominal determiner. There is no *a priori* reason to assume that *kak* cannot also have multiple functions. We are not interested in the function of *kak* in the above contexts, and what it does or does not do there has no bearing on its function in the relevant contexts. Ultimately, Marelj and Matushansky's objection to the treatment of *kak* as an overt predicator does not hold.<sup>29</sup>

Distribution of small clauses with overt vs. null Pr heads varies by language. In English, the type of small clause head is conditioned by the matrix verb. For example, *regard*, *think of*, and *honor* all select small clauses with the overt Pr head *as*. In contrast, *think*, *make*, and *name* select small clauses with the null Pr head:

- (53) a. Winthrop regarded Amaryllis \*(as) intimidating  
b. Mayor Shinn thought of Tommy \*(as) a hooligan  
c. Miser Madison honored Marian \*(as) the River City librarian  
d. Marcellus thought Harold (\*as) on his game

---

<sup>29</sup>They also present objections to treatment of *za* as an overt predicator; their preference is to analyze it as a preposition, and they present a range of anaphor binding data as support. Their treatment of *za* as a preposition is more convincing than their treatment of *kak*. Consequently I will remain agnostic about the function of *za*. However, there is stronger evidence for *kak* as an overt predicator in Russian, and Marelj and Matushansky (2009) make no arguments one way or another about the analysis of the relevant functional particles in Welsh, Edo, etc., as overt predicators.

- e. Years of grift made Harold (\*as) sneaky
- f. The Ladies' Auxiliary named Eulalie (\*as) leader of the Classical Dance

But one English matrix verb, *consider*, appears to have variable selection properties:

- (54) Marian considered Harold's question (as) out of line

In Russian, however, the matrix verb does not appear to have selection restrictions on the type of Pr head its PrP complement can have. Below, (35) and (36) are repeated for convenience:

- (55) a. My sčitaem ego svoim  
 We consider him.ACC self's.INSTR  
 "We consider him one of us"
- b. my tancevali p'janymi  
 We danced drunk.INSTR  
 "We danced drunk"
- c. On vygljadit durakom  
 he-Nom looks fool.INSTR  
 "He looks (like) a fool"
- (56) a. My sčitaem ego kak svoego  
 We consider him.ACC Pr self's.ACC  
 "We consider him one of us"
- b. my tancevali kak p'janye  
 We danced Pr drunk.NOM  
 "We danced drunk"
- c. On vygljadit kak durak  
 he-Nom looks Pr fool.NOM  
 "He looks (like) a fool"

The (a) examples show the lack of selection restrictions for *sčitat'sya*, a prototypical

example of an SC-complement-taking verb. The (b) examples show the lack of sentence-level restrictions on realization of Pr in depictive adjuncts. And the (c) examples show the lack of selection restrictions for *vygljadet*, a raising verb.

To summarize, in Russian, Pr has (at least) two realizations: a phonetically null variant that occurs with instrumental-marked predicates, and the phonetically overt word *kak*, which cannot occur with instrumental-marked NP predicates. Other languages, including English, show evidence of a phonetically overt Pr head. The existence of overt variants provide evidence for the functional category Pr, and thus for the structural analysis of English small clauses discussed above.

## CHAPTER 3

### REJECTING A STRUCTURAL TYPOLOGY OF SMALL CLAUSES

#### 3.1 English-type and Irish-type

To this point I have implied that small clauses are the same category cross-linguistically. However, it has been proposed at various times that they need not be the same category in each language. The first proposal of this kind that I know of is from Chung and McCloskey (1987). Irish has [NP NP] and [NP AP] structures that look like small clauses, such as the following:

- (1) a. tharlaigh [na bailte faoi rathúnas an bhliain sin]  
happened the towns under prosperity the year that  
“The towns happened to be prosperous that year”
- b. níor ghortaigh sé éinne ariamh ach [é lách carthanach i gcónaí]  
NEG hurt he anyone ever but him gentle charitable always  
“He never hurt anyone, but was always gentle and charitable”
- c. is trua gan céim agat  
COP.PRES pity nor degree at you  
“It’s a pity you don’t have a degree”

The core of their argument – that small clauses, and likely other constructions in syntax, are not universal in structure – is based on differences between small clauses in English and Irish. They begin by assigning the following structure to Irish clauses:

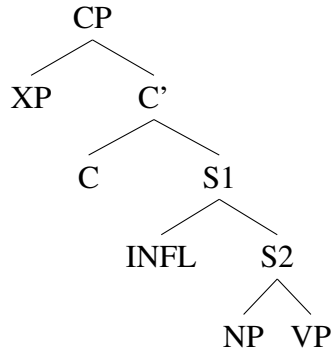

Figure 3.1: Clause structure in Irish

Operating within a *Barriers*-style model of Government and Binding, they adopt the doubly articulated CP of Chomsky (1986) but deny that Irish has a doubly-articulated IP/TP.<sup>1</sup> Instead, it has an iterated non-maximal category S, which is headed by INFL but does not project to IP. Roughly, S1 is equivalent to I', and S2 is a small clause and an adjunct. Every tensed clause contains a small clause complement with a VP predicate. Small clause complements to heads other than INFL may have NP, PP, or AP predicates, as in English, and have the following structure:<sup>2,3</sup>

<sup>1</sup>For reasons internal to GB regarding government of subjects.

<sup>2</sup>I have not discussed VP-type small clauses yet because I remember at one point talking about why they weren't small clauses at all and I don't remember the details; also i had hoped to get by without talking about them at all, if possible. not sure if i can manage that if I'm going to talk about chung and mcloskey.

<sup>3</sup>Chung and McCloskey (1987) acknowledge that at a glance, it is unclear how their small clause is different from one popular variation of the small clause as construed by Stowell (1981, 1983). Both are smaller than IP, and if we consider them together the similarity is obvious:

- (i) a. [S NP XP]
- b. [XP NP XP]

Recategorization from XP to S turns out to matter: for Chung and McCloskey, S cannot be XP because S is not a maximal projection, where XP is by definition a maximal projection; further, they assume a rewrite rule which defines S as the only possible sister of C; and they also argue that XP, which is not a proposition, is the wrong semantic type to be a complement of C.

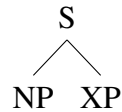

Figure 3.2: Structure of Irish small clauses

Their model explicitly allows for cross-linguistic variation. Although Irish does not have a doubly-articulated S (=IP), they agree that English does, following evidence in Chomsky (1986). Consequently, finite and non-finite clauses in English have the following structure:

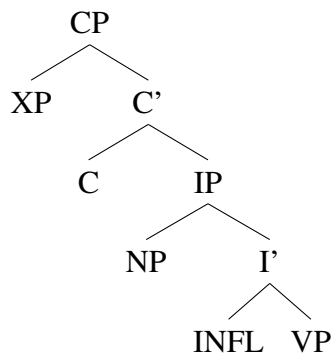

Figure 3.3: Clause structure in English

Here, S is equivalent to IP, which means that S is a maximal projection of INFL. Small clauses cannot be category S because small clauses lack INFL, so Chung and McCloskey adopt a dual model of small clauses. In Irish (and any other language where S is not a projection of INFL), small clauses are category S, with the structure shown in Figure 3.2. English (and any other language where S is a projection of INFL), in contrast, does not have small clause constituents, and Williams (1980, 1983) is correct that English has ternary-branching VPs:



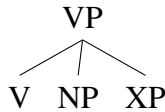

Figure 3.4: Ternary-branching VP

They propose a dual model, but interestingly, they lay the groundwork for a triple model. They argue that “. . . there are languages in which S is a projection of Infl [like English], languages in which S is a projection of V, and languages in which S is not a projection of anything [like Irish]” (1987: 235). They briefly direct the reader to Williams (1983) and Chomsky (1986) for the best analysis of small clauses in languages of the first type, discuss at length a different analysis of small clauses in languages of the final type, and imply that small clauses in language may have a still different structure. They are explicit about their view of variation in syntactic structure: “It is thus necessary for the theory of grammar to allow at least some (language-particular) phrase structure configurations that conform to no principled cross-categorial pattern” (1987: 235).

They were, however, working within a now-outdated framework. Within a Minimalist framework,  $X^0$  by definition must project XP; otherwise it’s not a head. In Irish, S may contain the INFL head, so S must be equivalent to IP/TP, exactly as in English. Further, as we saw in Section 2.2.3, we now have a category for small clauses that is bigger than XP, smaller than TP, and doesn’t necessitate ternary branching: PrP. And Irish small clauses fit into this model as well as English ones do:<sup>4</sup>

---

<sup>4</sup>The small clause’s DP subject may move to spec-PrP of the matrix clause, either overtly or at LF, and may move to spec-TP at LF. Neither would affect word order; I leave it an open question whether this happens. For thorough discussions of the syntactic machinery required to achieve Irish word order, interested readers should consult Doherty (1996), Carnie and Harley (1996), Carnie and Guilfoyle (2000), and McCloskey (2005).

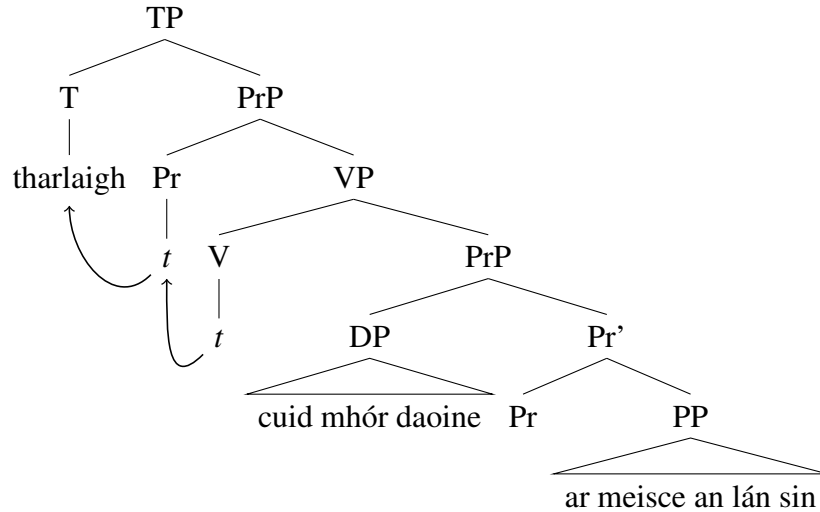

Figure 3.5: The structure of *Tharlaigh [cuid mhór daoine ar meisce an lán sin]* (“It happened that many people were drunk that day”). The bracketed phrase is a small clause.

Interestingly, Chung and McCloskey are right that small clauses are different in English and Irish, but not for the reasons they conclude. Small clauses have very different distribution in the two languages. In Irish, small clauses occur in adjuncts formed with the conjunctions *agus* (‘and’) and *ach* (‘but’); can stand on their own as sentences; and are complements of verbs like *tarlaigh* (‘happen’), adjectives like *annamh* (‘rare’), and *gan* which is typically analyzed as a preposition meaning *without* but, Chung and McCloskey argue, can also function as a complementizer meaning *nor*:

- (2) a. Bhuail mé leis agus é ar an bhealach ’na bhaile  
 struck I with him and him on the way home  
 “I met him as he was on the way home”
- b. Níor ghortaigh sé éinne ariamh ach é lách carthanach i gcónaí  
 NEG hurt he anyone ever but him gentle charitable always  
 “He never hurt anyone, but was always gentle and charitable”
- c. Iad ríghin fadthruslógach.  
 them tough with long loping stride  
 “They were tough and walked with a long loping stride.”

- d. Tharlaigh cuid mhór daoine ar meisce an lá sin  
happened many people in drunkenness the day that  
“It happened that many people were drunk that day”
- e. Ba annamh mo dheartháir sásta  
COP.PAST rare my brother satisfied  
“My brother was rarely satisfied”
- f. Ba mhinic gan é sa teach  
COP.PAST often nor him in the house  
“He was often not in the house”

In contrast, small clauses in English have a more limited distribution. They can be complements of a verb, complements of a preposition, or (with a PRO subject) depictive adjuncts:

- (3) a. Mayor Shinn considered [<sub>PrP</sub> Harold [<sub>AP</sub> slipperier than a Mississippi sturgeon]]
- b. With [<sub>PrP</sub> Harold [<sub>PP</sub> in jail]], the band wouldn't have a leader
- c. Marian drank the cherry phosphate [<sub>PrP</sub> PRO [<sub>AP</sub> cold]]

We can attribute these distributional differences to variation in Case assignment in the two languages. In English, the Pr head projects a subject and mediates between the subject and predicate, but is otherwise syntactically empty. Thus the small clause subject must be assigned Accusative Case by a Case-assigning head such as a preposition or the matrix VoiP.<sup>5</sup> In Irish, if an external Case assigner is available,<sup>6</sup> it assigns Accusative Case to the specifier of Pr, as in (2-d). But the Pr head is syntactically richer than in English. Just in case an external Case assigner is not available, it can assign inherent Case to its specifier,<sup>7</sup> the small clause subject, and the small clause need not be a complement

<sup>5</sup>which I have thus far excluded from structural trees for simplicity.

<sup>6</sup>Such as a matrix VoiP in which the small clause is embedded as a complement.

<sup>7</sup>Bowers (2010) argues that inherent case is always assigned to a specifier by its head.

to an external Case assigner, as in English. As a result, a small clause can form a grammatical sentence on its own, as in (2-c). It can also form adjuncts with lexical subjects as in (2-a) and (2-b), whereas in English adjunct small clauses must have Case-less PRO subjects.<sup>8</sup>

Thus I must conclude that small clauses in English and Irish have the same structure; the only difference is in the Case-assigning ability of the Pr head.

### 3.2 English-type and Chinese-type

In his dissertation, Tang (1998) hypothesizes a different typology of small clauses – ‘bare’ (Chinese-type) and ‘not-so-bare’ (English-type). The typology is designed to explain the difference between predicates in English and Chinese. In English, the nominal predicate of a small clause is a DP which may – and often must – be headed by an overt determiner:

---

<sup>8</sup>A question remains about the structure of the small clauses introduced by *gan*, a word that serves several functions in Irish. It can be a complementizer meaning ‘nor’, but most commonly it is a preposition meaning ‘without’. Chung and McCloskey argue that in sentences like (2-f) it is a complementizer. Their primary evidence is that the preposition *gan* causes lenition of the initial consonant of the following noun under certain conditions, while complementizer *gan* never does. However, lenition does not occur on modified nouns. Consider its effects on the non-lenited form *pingin* (‘penny’):

- (i) a. gan phingin  
without a penny  
“without a penny”
- b. gan pingin ina phóca  
without a penny in his pocket  
“without a penny in his pocket”

The [gan NP XP] structures at issue are exactly the structures that would not show lenition, as the NP is modified by the XP. Ultimately, it does not make a huge difference to my analysis whether *gan* is here a preposition or a complementizer. If it is a preposition, it can assign Case to the small clause subject. If it is a complementizer, a matrix VoiP can assign Case instead. Or, if either of these processes fails, the Pr head can assign inherent Case to its specifier.

- (4) a. Concerned parents considered the pool table [DP (a piece of) garbage]  
 b. The ladies named Eulalie [DP (the) president of the Ladies' Auxiliary]  
 c. Marcellus considers Harold [DP \*(a) genius]  
 d. We voted it [DP (the) most uncomfortable chair]  
 e. They named the town [DP (\*the) River City]

We can predict when the predicate will or will not allow an overt determiner. The overt determiner is optional when the predicate and its subject are equative, and the predicate has a uniqueness presupposition. In (4-b), *Eulalie* and *(the) president of the Ladies' Auxiliary* refer to the same entity, and the predicate is unique. In (4-d), *it* and *(the) most uncomfortable chair* refer to the same entity, and the predicate is unique. In (4-e), *the town* and *River City* refer to the same entity, and the predicate is unique; because it is also a proper noun, the overt determiner is impossible instead of optional, because proper nouns in English do not take overt determiners.

According to Tang, in Chinese the nominal predicate of a small clause may not contain classifiers typically analyzed as overt D heads:

- (5) a. Zhangsan dang ta (\*yi-ge) shagua  
 John consider he one-CL fool  
 "John considered him a fool"  
 b. Ni dang na (\*yi-wan) renshen tang  
 You consider that one-bowl ginseng soup  
 "You consider that a bowl of ginseng soup"

Adjectival predicates also behave differently in English and Chinese. In English, adjectival small clause predicates can take (multiple) degree modifiers:

- (6) a. Marian considers Mary [<sub>AP</sub> very intelligent]  
b. John believed Mary [<sub>AP</sub> almost entirely insane]

In contrast, in Chinese, adjectival small clause predicates cannot take degree modifiers:

- (7) Wo zan ta (\*hen) piaoliang  
I praise she very pretty  
“I consider her very pretty”

We can account for these differences structurally, Tang argues. English has ‘not-so-bare’ small clauses, which contain a mediating functional phrase between the subject and the predicate, similar to Bowers (1993). Chinese has ‘bare’ small clauses, which do not contain this functional phrase; instead they are the XPs of Stowell (1981, 1983).

In the typology set forth by Tang, small clauses in English are fully articulated CPs, with the following structure for *Mary a genius*:

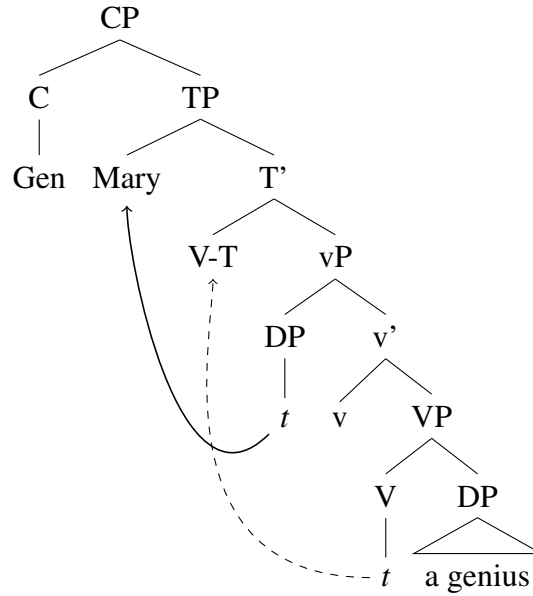

Figure 3.6: ‘Not-so-bare’ small clause, per Tang (1998)

Notably, ‘not-so-bare’ small clauses are TPs with the same structure as tensed clauses,<sup>9</sup> which suggests that ‘small clause’ is a misnomer. In a not-so-bare small clause, the predicate XP is a complement of a null copula in V; it is VP itself that functions as the predicate, while the ‘predicate’ XP is actually an argument of the null copula. The subject is generated in the same position as the subject of a tensed clause, as the specifier of a functional head that takes VP as a complement. He follows Chomsky (1995) in suggesting that this category is vP, although he concedes that others have proposed different categories for this purpose.<sup>10</sup>

In contrast, small clauses in Chinese are actually small (i.e. consist of fewer projections than a tensed clause). They are ‘bare’ XPs that are not complements of V and

<sup>9</sup>Tang (1998) directs readers to Kreps (1994) for an argument for VP and TP in English small clauses; and to Kitagawa (1985) for an argument that English small clauses must be CP. Concerning the latter, see Section 2.2.2. The C head, Tang argues, is either a generic operator Gen or episodic operator Ep, which dictates whether the predicate of a small clause receives an individual-level or stage-level interpretation. The V head is filled with a null copula; see Section 4.

<sup>10</sup>See Footnote 2.2.3, Footnote 14.

are not mediated by a functional head. He assigns the following structure to *cheng ta shagua* ('call him a fool'):<sup>11</sup>

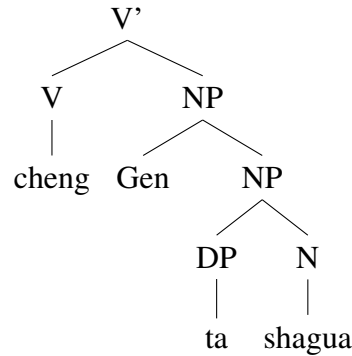

Figure 3.7: ‘Bare’ small clause, per Tang (1998)

In a ‘bare’ small clause, there is no VP containing a null copula, and no vP to mediate between subject and predicate VP. The small clause is a bare lexical projection of the predicate  $X^0$ , whose specifier is the subject. According to this structure, there simply isn’t room for a classifier.

If N can be a predicate that merges directly with its subject, then we might ask, why can’t D be a predicate that merges directly with its subject, such that the specifier of DP is the subject of a  $D^0$  predicate? This would presumably allow small clauses in Chinese whose nominal predicates have classifiers. To bar this, Tang appeals to  $\theta$ -binding.

According to Tang, a D head  $\theta$ -binds an NP so that the nominal may function as an argument. The Gen operator is also a  $\theta$ -binder – as a C head in a tensed clause or ‘not-so-bare’ small clause, it  $\theta$ -binds the predicative V-T. In a ‘bare’ nominal small clause,

<sup>11</sup>Small clauses in Chinese appear with the verb *dang* (‘consider’) as well as verbs of speech such as *cheng* (‘call’) and *ma* (‘scold’). However, in the context of a small clause *dang* behaves very differently than the verbs of speech – it can enter passive constructions and *ba*-constructions, whereas verbs of speech cannot. For this and other reasons, the small clause associated with *dang* is considered to be an adjunct with a PRO subject controlled by a matrix argument, while the small clauses associated with the verbs of speech are complement small clauses with lexical subjects. See Tang (1998) for a thorough discussion of the differences between *dang* and the verbs of speech.



the N head may be  $\theta$ -bound only once – by a classifier in D or by Gen, which adjoins to NP. Because ‘bare’ small clauses do not allow classifiers, they must have Gen instead, as an adjunct to the small clause.

Tang extends this treatment to adjectival small clauses.<sup>12</sup> He treats degree words as heads of Degree Phrase, where Deg  $\theta$ -binds the adjective. In Chinese, Gen  $\theta$ -binds the adjective, which bars Deg. In contrast, in English, Gen  $\theta$ -binds V-T instead, so Deg can  $\theta$ -bind the adjective.

There are glaring problems with this analysis. First, in Section 2.2.3 I noted that if small clauses are TPs, we must include an additional stipulation or structural mechanism that prevents tense mismatch between embedded and matrix clauses. Tang explicitly stipulates that small clause TPs in English are tenseless, but does not hypothesize a structural explanation. In either case, his model of small clauses in English is necessarily more complex than one in which small clauses are PrPs.

Second, there is no *a priori* reason to stipulate that predicate nominals are arguments, and the only reason provided by Tang – that in English, predicate nominals are DPs not NPs – is descriptive, not explanatory, so I will discard that stipulation.

Third, Tang misrepresents  $\theta$ -binding. In Higginbotham (1985)’s formulation,  $\theta$ -binding discharges an argument position; e.g. a determiner such as *the* converts a generic noun such as *dog*, which is a one-place predicate, to type  $\langle e \rangle$ , thus allowing *the dog* to function as an argument.  $\theta$ -binding applies in exactly two contexts: INFL (=T)  $\theta$ -binds the event of VP, and determiners  $\theta$ -bind generic nouns. Structurally, a head  $\theta$ -binds its sister, which must be a different category – i.e. a  $\theta$ -binder cannot  $\theta$ -bind itself. Tang’s model flouts these conventions. T is not a  $\theta$ -binder; rather, it must be  $\theta$ -bound. Predicate nominals are  $\theta$ -bound by an adjunct, which means that Gen  $\theta$ -binds the phrase which

---

<sup>12</sup>Recall that in English, adjectival predicates may be modified by degree; in Chinese, they cannot.

contains it and, by extension, itself. And he extends the operation to adjectives. Tang himself claims that adjectives are not arguments, so it is unclear why they would be  $\theta$ -bound. If it turns out that adjectives must be  $\theta$ -bound, we then have no explanation for why Deg is merely optional, rather than obligatory, in English. Tang stipulates that Deg may be phonetically empty, but offers no justification or references to support this stipulation.<sup>13</sup> Tang makes significant alterations to  $\theta$ -binding as a theoretical construct, and again, he provides no justification or references in support.

But there is a more fundamental problem with Tang’s analysis: his characterization of the small clause data is incorrect. Here, I provide a wide sample of Chinese sentences in order to get at facts about small clauses in Chinese.

Small clauses surface in one of two ways, with or without *wei* (‘as’); matrix verbs vary in whether they can co-occur with *wei*. For example, *cheng* (‘call’) may take a small clause complement with *wei*, but *jiao* (‘call’) cannot:

- (8) a. Zhangsan cheng ta (wei) laoshi  
 John call him as teacher  
 “John calls him a teacher”
- b. Zhangsan jiao ta (\*wei) laoshi  
 John call him as teacher  
 “John calls him a teacher”

Nominal predicates in small clauses need not be bare – they can be modified by simple adjectives, adjectives modified by degree, relative clauses, and prepositional phrases:

---

<sup>13</sup>This is in stark contrast to nominals, which are widely considered to be DPs whose head may be phonetically empty if a given language allows. See Ghomeshi and Massam (2011) for discussion and extensive references; see Bilous (2011) for a brief overview.

- (9) a. Zhangsan jiao ta xiao guniang  
John call her little girl  
“John calls her a little girl”
- b. Zhangsan jiao ta feichang hao de laoshi  
John call him very good DE teacher  
“John calls him a very good teacher”
- c. Zhangsan jiao ta ai xuesheng de laoshi  
John call him love students DE teacher  
“John calls him a teacher who loves students”
- d. Zhangsan cheng ta (zai) yusan xia de laoshi  
John call him (at) umbrella under DE teacher  
“John calls him [a teacher under an umbrella]”

When selected by *cheng*, they are equally acceptable with or without *wei* (‘as’):

- (10) Zhangsan cheng ta (wei) feichang hao de laoshi  
John call him as very good DE teacher  
“John calls him a very good teacher”

In the presence of *wei*, the nominal predicate may take an optional determiner and classifier, which according to Tang is banned in Chinese:

- (11) a. Zhangsan cheng ta wei (yi ge) feichang hao de laoshi  
John call him as (a CL) very good DE teacher  
“John calls him a very good teacher”
- b. Zhangsan cheng ta wei (yi ge) ai xuesheng de hao laoshi  
John call him as (a CL) love student DE good teacher  
“John calls him a good teacher who loves students” (cf. (9-c))

In some sentences, the classifier is licit even without *wei*:

- (12) a. Zhangsan jiao ta yi ge (zai) yusan xia de laoshi  
John call him a CL at umbrella under DE teacher  
“John calls him a teacher under an umbrella”

- b. Zhangsan cheng ta yi ge shijie shang zuihao de renxuan  
 John call him a CL world in best DE candidate  
 “John considers him the best candidate in the world”

Further, different classes of determiners are equally possible – possessives as in (13), quantifiers as in (14), and demonstratives as in (15):

- (13) a. wo cheng Nike (wei) Aimi de didi  
 I call Nick as Amy POSS brother  
 “I call Nick Amy’s brother”
- b. wo cheng ta (wei) (wo de) didi  
 I call him as I POSS brother  
 “I call him my brother”
- (14) a. Wo dang tamen si ge hao bangshou  
 I consider they four CL good helper  
 “I consider them four good helpers”
- b. wo cheng Mali he Aimi (wei) liang ge shagua xuexiao de hao  
 I call Mary and Amy as two CL fool school DE good  
 xueshang  
 student  
 “I call Mary and Amy two good students in a school of idiots”
- c. Zhangsan cheng Mali he Aimi (wei) ta zuihao de ji ge  
 John call Mary and Amy as he best POSS several CL  
 xuesheng  
 student  
 “John considers Mary and Amy some of his best students”
- d. Zhangsan cheng Mali, Aimi he Jian wei keyiyuehui de mei (yi)  
 John considers Mary, Amy and Jane as datable DE every (one)  
 ge nvhai  
 CL girl  
 “John considers Mary, Amy and Jane every datable girl [in school]”
- (15) Zhangsan cheng Mali (wei) na ge jiu-le ta de ren  
 John call Mary as that CL save he DE person  
 “John calls Mary that person he saved”

And, contra Tang, adjectival predicates may take degree modifiers:

- (16) a. wo renwei Mali (hen) yonggan  
I think Mary very brave  
“I consider Mary very brave”
- b. Zhangsan cheng Mali hen shihe zuo na ge gongzuo  
John call Mary very suitable do that CL job  
“John considers Mary very suitable for that job”

Sentences like these are not an idiolectal artifact of a single speaker: they are widely attested in the Google corpus. The remaining Chinese sentences are taken from a google.cn corpus search (July 2, 2012). Sentences in (17) have nominal predicates with modifiers, corresponding to sentences in (9):

- (17) a. dajia jiao ta xiao wangzi  
everybody call him little prince  
“Everybody calls him a little prince”
- b. xuesheng jiao ta zui mei de laoshi  
Student call her most beautiful DE teacher  
“Students call her the most beautiful teacher”
- c. meiti cheng ta paoche li de zhandouji  
Media call it sports-car among DE fighter-plane  
“The media calls it a fighter plane among sports cars”

Sentences in (18) have nominal predicates with classifiers, corresponding to sentences in (12):

- (18) a. wo jiao ta yi ge yinghua-shu xia de chengnuo  
I call it a CL cherry-tree under DE promise  
“I call it a promise under the cherry tree”
- b. renmen cheng Qiaobusi yi ge shijie shang zuihao de chanpin jingli  
people call Jobs a CL world in best DE product manager  
“People consider (Steve) Jobs the best product manager in the world”

Sentences in (19) have nominal predicates with possessive markers, corresponding to sentences in (13):

- (19) a. xiaopengyou cheng mihoutao (wei) taozi de didi  
children call kiwi (as) peach POSS brother  
“Children call the kiwi the peach’s brother”
- b. feizhou ertong cheng ta (wei) (tamen de) yangguang-jiejie  
African children call her (as) (they POSS) sunny-sister  
“African children call her their sunny sister”

To summarize: in Chinese small clauses, neither nominal nor adjectival predicates must be bare lexical projections. Nominal predicates may be modified, for example with APs, and may occur with determiners and classifiers. Adjectival predicates may be modified by degree.

In English, phrases that can function as predicates of small clauses can also function as predicates of main clauses. The facts observable from the data presented above show that the same is true in Chinese. In both English and Chinese, adjectival predicates may be bare adjectives or modified adjectives. English requires count nouns to have overt determiners, so nominal predicates have determiners. Chinese allows, but does not require, count nouns to have overt determiners and classifiers, so nominal predicates may – but need not – have overt determiners and classifiers. We can draw this conclusion: in English and Chinese, a predicate is a predicate, whether it is in a small clause or a main clause.

We need only look briefly at the structure proposed in Tang (1998) for ‘bare’ small clauses to realize that it does not describe Chinese small clauses – there simply isn’t enough room in the tree to fit all the parts. So the question naturally arises, what structure should we assign to small clauses in Chinese? I propose that it is the same structure

as for English small clauses – but not the model Tang proposes. I have already established that small clauses do not have TP (they lack agreement and tense features). I leave it as an open question whether small clauses can project CP in order to facilitate *wh*-movement, and the presence or absence of a Gen or Ep operator in C (which is phonetically null and relevant only at LF) is inessential to my proposal. This leaves us with vP, a ‘mediating’ category that allows a subject to merge with a predicate – tantalizingly similar to PrP.

How does a phrase become a predicate? According to Tang, all predicates are VPs; nominal ‘predicates’ are actually arguments, which is accomplished via  $\theta$ -binding by  $D^0$  or Gen. Adjectival and prepositional ‘predicates’, which are not arguments, are merely complements of V (although they still must be  $\theta$ -bound by an operator,  $Deg^0$  or Gen). VP, we are left to assume, is inherently a predicate. The vP shell is necessary to provide sufficient argument positions for double-object constructions, but does not have predicational properties.

In contrast, within the PrP model, no lexical category must ‘inherently’ be a predicate to the exclusion of all others; rather, it is the primary function of the Pr head to convert an XP into a predicate and merge that predicate with its subject. Pr has different selectional restrictions in different languages – for example, in English, PP can project PrP, but in Chinese, it cannot. This has the added benefit that, within the context of predication, the structure of the nominal or adjectival phrase is inessential. If there are Degree heads that take AP complements, then DegP projects PrP; if degree modifiers are adjuncts, then only AP projects PrP. If bare nominals in Chinese do not project DP, then NP projects PrP; but if Chinese bare nominals are actually DPs with a null D head, then only DP projects PrP.

Further, there is a strong candidate for an overt Pr head in Chinese: *wei* ('as'). When it has rising tone, *wei* is used in only one syntactic context – inside of a small clause. It seems uncontroversial to assign this morpheme to the category Pr.

Based on a larger data sample, I conclude that small clauses in Chinese are 'not-so-bare' and that they have the same structure as small clauses in English, Russian and Irish: 'larger' than XP, but 'smaller' than TP.



CHAPTER 4  
PRP AND COPULAR CLAUSES

## 4.1 Copular clauses in Polish, Arabic, and Welsh

In this thesis I have argued that small clauses, i.e. phrases with the structure [NP XP], are constituents. Small clauses have a mediating functional head (Pr) which allows function application: XP(NP). This is also basic purpose of copular verbs, and copular sentences are semantically similar to small clauses:

- (1) a. Eulalie is intimidating
- b. Mayor Shinn finds [Eulalie intimidating]

Copular verbs behave differently than other verbs with respect to nominals. In English, when ‘bare’ NPs occur with non-copular verbs, the nominal has a generic or mass interpretation, as in (2-a), but when the nominal has a definite or count interpretation, the nominal must have an overt determiner, as in (2-b):

- (2) a. Marian regularly reads great literature
- b. Mayor Shinn married \*(the) president of the Ladies’ Auxiliary

Copular clauses, however, allow the same range of nominals as small clauses do, full DP predicates and ‘bare’ NP predicates:

- (3) a. The women named Eulalie (the) president of the Ladies' Auxiliary  
 b. Eulalie is (the) president of the Ladies' Auxiliary

Consequently, many researchers (Partee, 1986; Heycock, 1992; Moro, 1997; den Dikken, 2006) claim that copular verbs should be treated independently of lexical verbs; some (Eide and Åfarli, 1999; Bowers, 2002; Citko, 2008) have proposed that copular verbs are overt realizations of a predicator head. If this is the case, then copular clauses are nothing more than small clauses with tense. Facts about copular sentences in Polish, however, indicate that such a unification is an oversimplification.

Citko (2008) identifies three kinds of Polish copular clauses: verbal, non-verbal, and dual, which contains both a verbal and a nonverbal copular element.<sup>1 2</sup>

---

<sup>1</sup>Citko refers to the non-verbal copula as the ‘pronominal’ copula, where *to* is a pronoun. However, for a Polish pronoun, *to* behaves very unusually. Polish pronouns surface in different forms depending on gender, number, virility, and case, but the pronominal copula always surfaces in the form *to* (neuter, nominative, singular). It does not agree with the subject, predicate, or verb (in dual copulas):

- (i) a. Maria to/\*ta (jest) moja najlepsza  
 Maria.VIR.SG.NOM NEUT.SG.NOM/FEM.SG.NOM is my best  
 przyjaciółka  
 friend.FEM.SG.NOM  
 “Maria is my best friend”  
 b. Jan i Tomek to/\*ci (są) moi najlepsi  
 John and Tom.VIR.PL.NOM NEUT.SG.NOM/VIR.PL.NOM are my best  
 przyjaciele  
 friends.MASC.PL.NOM  
 “John and Tom are my best friends”

Because *to* does not behave like a pronoun, referring to it as pronominal is incorrect, so I shall refer to these constructions as non-verbal copular constructions, and to *to* as the non-verbal copula.

<sup>2</sup>Recall that Polish has ‘true’ (i.e. non-copular) small clauses as well; I reproduce (46), with the overt predicator *za*, below for convenience:

- (i) Uwazam go za głupca  
 Consider.1.SG him.ACC PR fool.ACC  
 “I consider him a fool”

- (4) a. Jan jest moim najlepszym przyjacielem  
 John is my best friend  
 “John is my best friend”
- b. Jan to mój najlepszy przyjaciel  
 John PRON my best friend  
 “John is my best friend”
- c. Jan to jest mój najlepszy przyjaciel  
 John PRON is my best friend  
 “John is my best friend”

Verbal and pronominal copular sentences exhibit different syntactic behavior. Pronominal copulas require subject-predicate category-matching, whereas verbal copulas do not:

- (5) a. [<sub>DP</sub> Jan] to [<sub>DP</sub> mój najlepszy przyjaciel]  
 John PRON my best friend  
 “John is my best friend”
- b. \* [<sub>DP</sub> Jan] to [<sub>PP</sub> w przyjacielskim nastroju]  
 John PRON in friendly mood  
 “John is in a friendly mood”
- c. \* [<sub>DP</sub> Maria] to [<sub>AP</sub> mądra]  
 Maria PRON wise  
 “Maria is wise”
- d. [<sub>PP</sub> W domu] to [<sub>PP</sub> w domu]  
 at home PRON at home  
 “Home is home”
- e. [<sub>DP</sub> Maria] jest [<sub>AP</sub> mądrą]  
 Maria is wise  
 “Maria is wise”
- f. [<sub>DP</sub> Maria] jest [<sub>PP</sub> w domu]  
 Maria is at home  
 “Maria is at home”

Additionally, pronominal copulas require subject-predicate Nominative Case-matching, but the predicate of a verbal copula must have Instrumental Case:<sup>3</sup>

<sup>3</sup>See Citko (2008) for further differences regarding extraction possibilities and interpretation.

- (6) a. Warszawa to stolica Polski  
 Warsaw.NOM PRON capital.NOM Poland.GEN  
 “Warsaw is the capital of Poland”
- b. \*Warszawa to stolicą Polski  
 Warsaw.NOM PRON capital.INSTR Poland.GEN  
 “Warsaw is the capital of Poland”
- c. Jan jest lekarzem  
 John.NOM is doctor.INSTR  
 “John is a doctor”
- d. \*Jan jest lekarz  
 John.NOM is doctor.NOM  
 “John is a doctor”

Interestingly, dual copulas pattern with pronominal copulas, not with verbal copulas. So, dual copulas require subject-predicate category-matching, and subject-predicate Nominative Case-matching:

- (7) a. [DP Warszawa] to jest [DP stolica Polski]  
 Warsaw PRON is capital Poland  
 “Warsaw is the capital of Poland”
- b. \*[DP Warszawa] to jest [PP w Polsce]  
 Warsaw PRON is in Poland  
 “Warsaw is in Poland”
- (8) a. Warszawa to jest stolica Polski  
 Warsaw.NOM PRON is capital.NOM Poland.GEN  
 “Warsaw is the capital of Poland”
- b. \*Warszawa to jest stolicą Polski  
 Warsaw.NOM PRON is capital-INSTR Poland-GEN  
 “Warsaw is the capital of Poland”

To account for these syntactic differences, Citko follows Chomsky (1999) in arguing that there are two types of predicator heads,<sup>4</sup> complete and defective. According to Citko,

<sup>4</sup>Citko refers to these as  $\pi$  heads; I shall continue to refer to them as Pr heads for the sake of continuity.

a complete Pr head has uninterpretable  $\phi$ -features (which will be valued by its complement), a Case feature (in Polish, it will assign Instrumental Case to its complement), and no parallelism requirement (the subject and predicate need not be of the same category). In contrast, a defective Pr head lacks  $\phi$ -features, cannot assign Case, and has a parallelism requirement.<sup>5</sup> Under this hypothesis, verbal copular sentences have a complete Pr head, while pronominal and dual copular sentences have a defective Pr head.

For Citko, the complete Pr head is obligatorily realized as the copular verb *być* ('be'), which then raises to T where it will take on tense morphology, so that a sentence with a verbal copula such as (5-e) has the structure below:

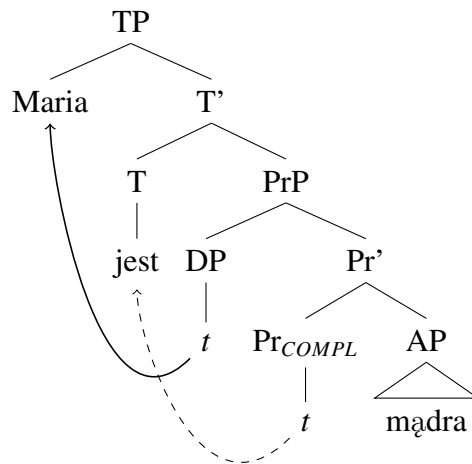

Figure 4.1: Polish copular sentence with complete Pr head ('Maria is wise')

In contrast, pronominal and dual copulas have deficient Pr heads. The deficient Pr head may be null or optionally realized as the copular verb *być* ('be'). According to Citko, the pronominal copula *to* is an expletive copula base-generated in T.<sup>6</sup> The tense

<sup>5</sup>Citko argues a further difference, that complete Pr heads have an eventive interpretation and defective Pr heads do not. See Citko (2008) for discussion.

<sup>6</sup>In two lengthy footnotes, Citko describes the multiple functions of *to* in Polish. For a thorough explanation of why *to* in this context is not a resumptive pronoun, proximate demonstrative pronoun, relative clause light head, correlative pronoun, or event marker, see Citko (2008).

and agreement morphology of *być* is not acquired by overt movement, but either by adjunction to *to* at LF or an Agree operation. Notably, the only difference between sentences with pronominal and dual copulas is the realization of the defective Pr head. The structures for (14-d) and (15-b) are identical, as shown in the figure below; I have indicated the optionality of the verb with parentheses:

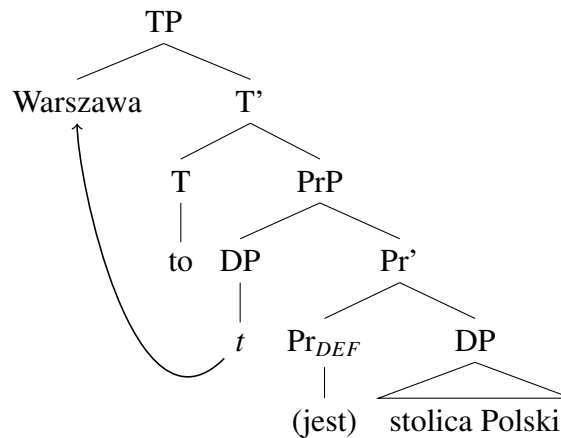

Figure 4.2: Polish copular sentence with defective Pr head ('Warsaw is the capital of Poland')

Essentially, Citko argues that PrP is a small clause, and that a copular clause is simply a TP with a PrP complement – that is, a tensed small clause – and that Polish is interesting because it displays variation in available copular clause structures.

There are two potential problems with Citko's analysis. First, the non-verbal copula has limited tense interpretation. Sentences with the non-verbal copula only have present tense interpretation (Magdalena Kanik, personal communication):

- (9) a. Jan to mój najlepszy przyjaciel  
 John COP my best friend  
 "John is (\*was/\*will be) my best friend"

- b. dzisiaj maria to odważna kobieta  
today Maria COP brave woman  
“Today Maria is a brave woman”
- c. \*wczoraj maria to odważna kobieta  
yesterday Maria COP brave woman  
“Yesterday Maria was a brave woman”

If *to* is base-generated in T, as Citko claims, and the non-verbal copular sentences are exclusively present tense, we might argue that *to* is overt present-tense morphology that surfaces in the absence of a verb that moves to T. This analysis is quickly ruled out, however, because as Citko points out, in dual copula structures *to* can freely co-occur with *być* in all three tenses:

- (10)
- a. Jan to jest mój najlepszy przyjaciel  
John COP is my best friend  
“John is my best friend”
  - b. Jan to był mój najlepszy przyjaciel  
John COP was my best friend  
“John was my best friend”
  - c. Jan to będzie mój najlepszy przyjaciel  
John COP will be my best friend  
“John will be my best friend”

If *to* is not merely a tense-marker, why should we assume it is base-generated in T? According to Citko (2008, p. 290) “this can be attributed to the fact that the pronominal copula *to* is an expletive copula.” But her claim is not even relevant, let alone explanatory. And it raises a further question: if *to* and *być* are equivalent, as Citko argues, why would they be base-generated in different positions, *to* (the tense-limited variant) in T and *być* (the tense-rich variant) in Pr? A virtue of Citko’s structure is that it yields Polish word order, but this benefit is purely descriptive, and Citko does not provide a good (or even a relevant) explanatory argument for the behavior of *to* and *być* in this context.

A further problem with Citko’s analysis is in her treatment of *być*. Why is the verbal copula optional just in case the Pr head is defective, and obligatory just in case the Pr head is complete? Why isn’t it always optional or always obligatory? Why doesn’t the overt verb differ from its null variant in a systematic way – or indeed, in *any* way that we can talk about? Citko does not address these questions at all.

To address these questions adequately, let us consider briefly consider Arabic. In Arabic, as in Chinese, [NP XP] structures are clausal and can function as complete sentences (Benmamoun, 2008). The nonverbal predicate may be nominal (11-a), adjectival (11-b), or prepositional(11-b):<sup>7</sup>

- (11) Moroccan Arabic
- a. ʕumar muʕəllim  
Omar teacher  
“Omar is a teacher”
  - b. d-ɖar kbira  
the-house big  
“The house is big”
  - c. lə-ktab fuq l-məktəb  
the-book on the-desk  
“The book is on the desk”

However, these sentences are necessarily interpreted as present-tense. Past-tense and future-tense equivalents must contain an overt copular verb:

- (12) a. ʕumar kan muʕəllim (MA)  
Omar was teacher  
“Omar was a teacher”

---

<sup>7</sup>All Arabic sentences in this section from Benmamoun (2008). MA = Moroccan Arabic; SA = Standard Arabic.



- b.  $\zeta$ umar ya $\dot{d}$ i ykun f- $\dot{*}$ d- $\dot{*}$ dar (MA)  
Omar will be in-the-house  
“Omar will be in the house”
- c. kaana r-ra $\dot{z}$ ul-u mu $\zeta$ allim-an (SA)  
was the-man teacher  
“The man was a teacher”
- d. sa-kuunu r-ra $\dot{z}$ ul-u mu $\zeta$ allim-an (SA)  
FUT-be the-man teacher  
“The man will be a teacher”

To explain this dichotomy, Benmamoun proposes that in Arabic, the present-tense T head is specified for different features than the past- and future-tense T heads. The present-tense T head is specified [+Present, +D]: it is present tense and it enters a Probe-Goal relationship with the subject DP. In contrast, the past-tense T head is specified [+Past, +D, +V] and the future-tense T head is specified [+Future, +D, +V]. The [+V] feature necessitates an overt verb to host the tense morphology. However, because the present-tense T head lacks a [+V] feature, non-verbal predicates may project TP. Thus, present-tense copular clauses in Arabic have the structure in Figure 4.3:

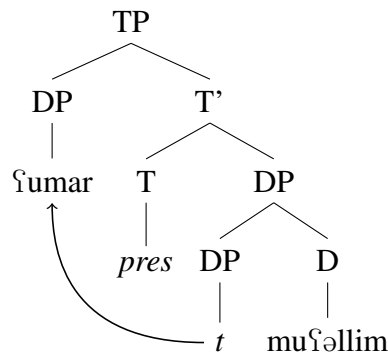

Figure 4.3: Arabic present-tense copular sentence (‘Omar is a teacher’)

Past-tense copular clauses in Arabic have the structure in Figure 4.4, which is analogous to the structure of future-tense copular clauses:

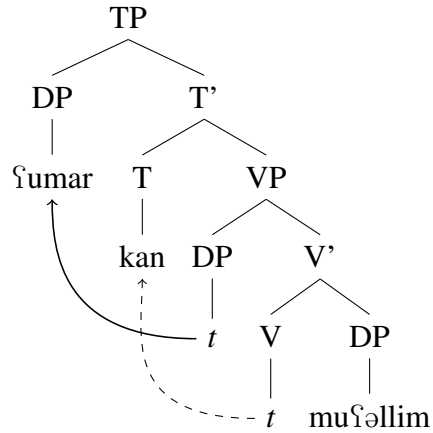

Figure 4.4: Arabic past-tense copular sentence ('Omar was a teacher') (Benmamoun, 2008)

For Benmamoun, languages with verbal copulas have T heads with [+V] features; languages with nonverbal copulas have T heads without [+V] features, with the result that nonverbal predicates may project TP. However, the present-tense structure has the same problem we encountered for English and Chinese (see Section 2.1 and Section 3.2), namely that the predicate XP is constrained because its specifier position is taken up by the predicate's subject.

Notably, Benmamoun's model eliminates a predicational functional layer. A similar analysis of Arabic which does implement a PrP layer is presented by Baker (2003). For Baker, as for Bowers (1993), the Pr head must be generated to license a subject. Thus,

Baker suggests the structure in Figure 4.5 for Arabic present-tense copulas,<sup>8</sup> and the structure in Figure 4.6 for Arabic past-tense and future-tense copulas.

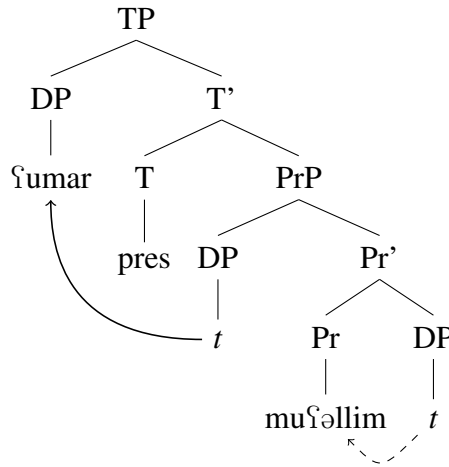

Figure 4.5: Arabic present-tense copular sentence (‘Omar is a teacher’) (Baker, 2003)

<sup>8</sup>In Arabic, copular sentences with non-verbal predicates are negated in two ways, as shown below:

- (i) Moroccan Arabic
- a. ʔumar ma-ʕi muʔallim  
Omar NEG-NEG teacher  
‘Omar is not a teacher’
  - b. ʔumar ma-muʔallim-ʕ  
Omar NEG-teacher-NEG  
‘Omar is not a teacher’

The standard analysis of Arabic negation is that a functional negative phrase, NegP, is a complement to TP. The negative proclitic (*ma* in MA) is the specifier of NegP; the negative enclitic (*ʕi* in MA) is the head of NegP. In a typical sentence with a verbal predicate, the verb Moves through the head of NegP, allowing the negative particles to cliticize onto the verb. Strict cyclicity requires the verb to Move through Pr on its way to NegP.

Nonverbal predicates may optionally Move to Neg, through Pr. Movement to Neg gives the word order in (i-a), in which the predicate is directly negated. When the predicate does not Move to Neg, however, the negative particles cliticize onto each other, giving the word order in (i-b).

It appears that only bare predicates may be directly negated in this way (Hamza Mahmoud, personal communication). It is not within the scope of this thesis to analyze these facts; however, it is worth pointing out in order to explain the movement of the nominal predicate to Pr in Baker’s example.

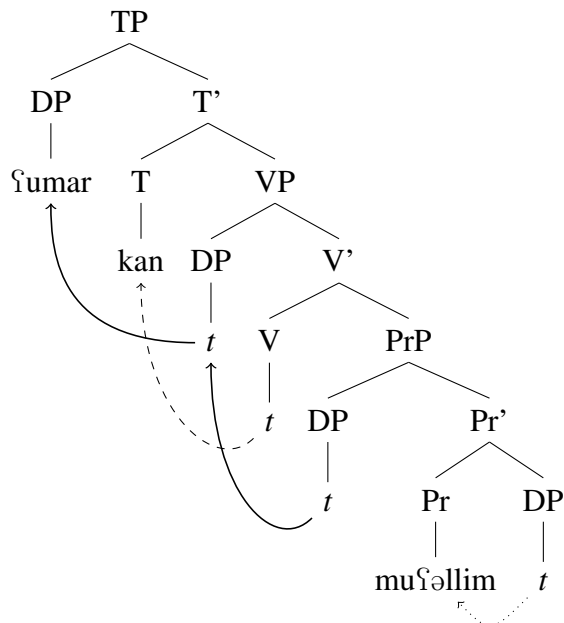

Figure 4.6: Arabic past-tense copular sentence (‘Omar was a teacher’) (Baker, 2003)

For Baker, in both types of copular sentences, the Pr head licenses the subject. The present-tense T head does not require a verb to carry tense morphology, but overt past- and future-tense morphology requires an overt verb.

Both Benmamoun and Baker model a two-way variance with two structures. Citko models a three-way variance with two structures. I propose that the three-way variance requires three structures, which we can formulate by combining Benmamoun’s, Baker’s, and Citko’s analyses.

For the sake of convenience, I repeat the three types of Polish copular clauses below. The first type contains the overt verbal copula *być* and lack the non-verbal copula *to*, as in (13). In these sentences, the subject’s case does not match the predicate’s case; and the subject’s syntactic category need not match the predicate’s syntactic category.

- (13) a. Jan jest moim najlepszym przyjacielem  
John is my best friend  
“John is my best friend”
- b. Maria jest mądrą  
Maria is wise  
“Maria is wise”
- c. Jan jest lekarzem  
John.NOM is doctor.INSTR  
“John is a doctor”

The second type contains the non-verbal copula *to* but not the verbal copula *być*, as in (14). In these sentences, the subject’s case and predicate’s case must match, and the subject’s syntactic category and predicate’s syntactic category must match.

- (14) a. Jan to jest mój najlepszy przyjaciel  
John PRON is my best friend  
“John is my best friend”
- b. \*[DP Maria] to [AP mądra]  
Maria PRON wise  
“Maria is wise”
- c. [PP W domu] to [PP w domu]  
at home PRON at home  
“Home is home”
- d. Warszawa to stolica Polski  
Warsaw.NOM PRON capital.NOM Poland.GEN  
“Warsaw is the capital of Poland”

The third type, the dual copula, contains both the non-verbal copula *to* and the verbal copula *być*, as in (15). In these sentences, the subject’s case and predicate’s case must match, and the subject’s syntactic category and predicate’s syntactic category must match.

- (15) a. [DP Warszawa] to jest [DP stolica Polski]  
 Warsaw PRON is capital Poland  
 “Warsaw is the capital of Poland”
- b. Warszawa to jest stolica Polski  
 Warsaw.NOM PRON is capital.NOM Poland.GEN  
 “Warsaw is the capital of Poland”

I propose that the verbal copula, as in (13), is truly predicative and contains a small clause as construed in Section 2.2.3, with a complete Pr head that mediates between the predicate and its subject. In Polish, the complete Pr head assigns Instrumental Case to the predicate. The small clause is the complement of the overt copula, which Merges as a V head and. I shall refer to this structure as the Pure Small Clause Copula structure, which contains a Pure Small Clause.

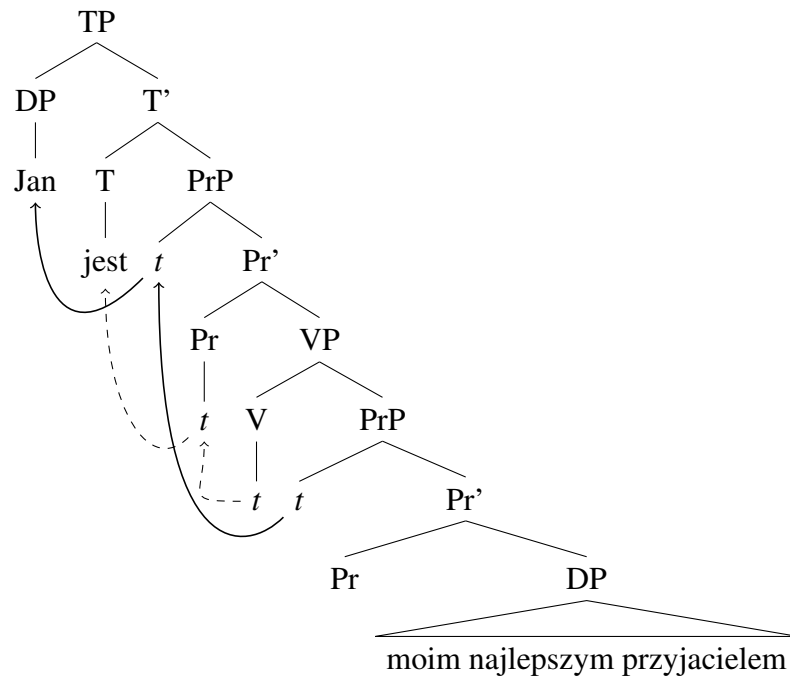

Figure 4.7: Pure Small Clause Copula (‘John is my best friend’)

The Pure Small Clause Copula is very similar to Baker’s structure for past-tense copular sentences in Arabic, with an additional PrP layer in the matrix clause – I treat

*być* as a raising verb; see Section 2.2.3 for a discussion of why raising verbs project PrP. I hypothesize that the Pure Small Clause Copula is the same structure as copulas in English, Spanish, and Russian.

The nonverbal copula, on the other hand, is not predicational and does not contain a small clause or Pr head. Instead, these structures are equative. The predicate projects TP directly. The head of T is similar to that proposed by Benmamoun for present-tense copular sentences in Arabic: it is specified [+Present, +D] but lacks a [+V] feature; therefore, no verb is required. To satisfy the [+D] feature, the subject Merges directly in spec-TP. This T head is realized as *to*, which has an equative interpretation. I refer to this structure as the Pure Equative Copula, and this structure may be the best structural analysis for copular sentences in Singala and the present-tense sentences in Arabic.

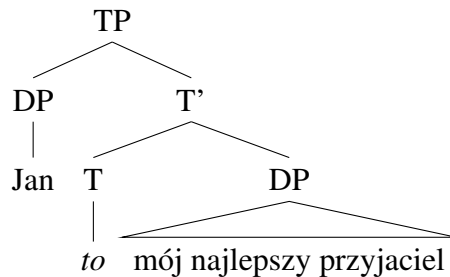

Figure 4.8: Pure Equative Copula ('John is my best friend')

Under this analysis, Pure Equative Copulas contain an identity relationship, rather than a predicational relationship. However, a question is raised: how is the subject interpreted if it is not the specifier of a PrP? I have explicitly argued that the Pr head mediates between a subject and predicate – essentially, the subject is interpreted as the subject because of its structural position as the specifier of PrP. I suggest that there are two ways a subject can be semantically interpreted. When PrP is projected, the specifier of PrP is necessarily interpreted as the subject. Alternatively, in the absence of PrP, the specifier of a different functional category (e.g. TP) may be interpreted as

the subject. This latter subject is impoverished: it receives no  $\theta$ -role. Consequently, the relation between the two phrases is interpreted as equational. The case- and category-matching facts are secondary to the identity relationship: they must match, because the phrases are equative.

The last structure, Citko's dual copula, is an intermediate structure. It is both equative and predicational, containing a PrP. It contains a T head specified [+Past/Present/Future, +D, +V], which is realized as *to* (the equative marker). Because it is specified [+V], an overt verb must be present to host tense morphology. The defective PrP cannot assign Instrumental Case to the predicate, whose case therefore matches the subject's case. Additionally, this head has a [+V] feature, so the verb *być* Merges as the head of Pr and adjoins to *to* to carry tense. However, it is not part of the extended projection of a verb. I shall refer to this structure as the Equative Small Clause Copula.<sup>9</sup>

---

<sup>9</sup>John Bowers and Wayne Harbert (personal communication) suggest that in a mixed copula, the defective Pr head may not allow a specifier. If this is true, then the subject will Merge directly in spec-TP, where it will be interpreted as the subject of an identity relationship. More data from other languages is necessary to resolve this question.



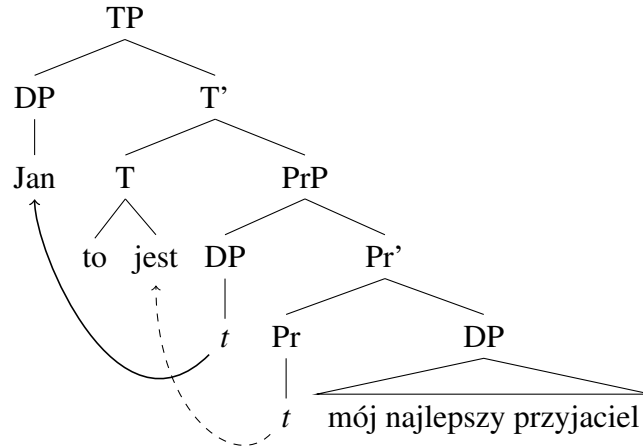

Figure 4.9: Equative Small Clause Copula ('John is my best friend')

In Polish, there are three possible T head. First, there is a null T head, which is specified for tense as well as [+D, +V]. This is the T head that occurs with lexical verbs and in the Pure Small Clause Copula. Second, there is a phonetically overt T head realized as *to*, which is specified [+Present, +D]. This is the T head that surfaces in the Pure Equative Copula. Third, there is a phonetically overt T head also realized as *to*, which is specified for tense as well as [+D, +V]. This is the head that surfaces in the Equative Small Clause Copula. Additionally, Polish has two Pr heads. First is a null Pr head that assigns Instrumental case to the predicate. This is the Pr head that generates a Pure Small Clause, which may function as a complement to a verb. This is the Pr head that occurs in the Pure Small Clause Copula. Second is a Pr head that does not assign instrumental case to the predicate and is realized as the copular verb *być*. This is the Pr head that occurs in the Equative Small Clause Copula.

Under this analysis, although the Equative Small Clause Copula is, in simple terms, a “small clause plus tense,” the Pure Small Clause Copula and the Pure Equative Copula cannot be accurately described this way.

Although this analysis is at first pass more complex than Citko's, it has several advantages. The realization of *być* is not arbitrary: it must Merge as the head of VP, or it must Merge as the head of defective Pr with its [+V] feature, but it is not optional in either context. It will never Merge as the head of complete Pr which lacks a [+V] feature. Further, we can predict why *to* occurs in the Pure Equative and Equative Small Clause copular constructions but not the Pure Small Clause copular construction. The variant of *to* without a [+V] feature selects a nonverbal complement XP, yielding the Pure Equative Copula. The variant of *to* with a [+V] feature can take a PrP complement containing the verbal copula *by*. In contrast, the null T head only allows the Pure Small Clause to function as its complement.

A further advantage is that this analysis applies to languages other than Polish; Welsh, for example. Like Polish, Welsh has the relatively unusual property that a verbal and non-verbal copula can co-occur – i.e. the Equative Small Clause copula. The Welsh copular verb is *bod* ('be'). In the present tense, *bod* is inflected several ways. One inflectional pattern and syntactic structure is used in the verbal copula structure, as follows:

- (16) a. diffoddwr dân ydy Gwyn  
 fighter fire be.3P.PRES Gwyn  
 "Gwyn is a fire fighter"
- b. car Aled ydy hwnna  
 car Aled be.3P.PRES this  
 "This is Aled's car"
- c. rhy barod i wthio 'i hunan ymlaen yw Siôn  
 too ready to push himself forward is Siôn  
 "Siôn is too ready to push himself forward"

A second inflectional pattern is used when *bod* functions as an auxiliary, as in (17-a) and in the dual copula, as in (17-b) and (17-c):<sup>10</sup>

- (17) a. Mae            bws yn dod  
           be.3P.PRES bus PR come  
           “A bus is coming”
- b. Mae            Gwyn yn ddiffoddwr dân  
           be.3P.PRES Gwyn PR fighter     fire  
           “Gwyn is a fire fighter”
- c. Mae            Gwyn yn ddiflas  
           be.3P.PRES Gwyn PR miserable  
           “Gwyn is miserable”

How, then, do we account for the verbal copula, which has the word order predicate-verb-subject, which is otherwise atypical in Welsh? Following Rouveret (1996), I argue that these are focus constructions, with the predicate in the left periphery. Borsley (2011) notes that PrPs with the overt predicator *yn* can also raise into the left periphery, yielding a different dual copula structure, in which the overt predicator is obligatory:

- (18) a. Bron \*(yn) barod ydy Mair  
           almost PR ready is Mair  
           “Mair is almost ready”
- b. Braidd \*(yn) siomedig ydy hi  
           Rather PR disappointed is she  
           “She is rather disappointed”

---

<sup>10</sup>A different dual copula pattern arises in sentences with dislocated subjects, in which a suppletive form of *bod* appears. The form, *sydd*, does not inflect for number, which is unusual for Welsh.

- (i) Rhys sydd yn athro  
       Rhys be.SUPP PRT teacher  
       “Rhys is a teacher”

In this focus construction, the subject raises out of its typical position into the left periphery; we might account for the different verb form by positing different selectional properties of the left-periphery heads, where the verb may raise. See Tallerman (1996), Hendrick (1996), and Rouveret (1996) for discussion.



- b. Tá an fear sin beag  
be.1SG.PRES.IND the man that small  
“That man is small”
- c. Bhíodh sé cróga  
be.3SG.IMPERF.IND he.NOM brave  
“He used to be brave”
- d. Beimid ar ais an tseachtain seo  
be.1PL.FUT.IND on back the week this  
“We will be back this week”

In contrast, the copula exhibits almost none of the syntactic behavior of verbs. It does not inflect for person, number, or mood, and subject pronouns appear with Accusative Case. The only thing it shares in common with Irish verbs is that inflects for tense, although even there it is impoverished. Typical Irish verbs inflect for present, habitual present, preterit, imperfect, and future tenses, along with conditional and imperative mood. But the copula has only two forms, *is* (present and future) and *ba* (generic past, conditional mood):

- (20) a. Is é Seán an múinteoir  
COP.PRES he.ACC Seán the teacher  
“Sean is the teacher”
- b. Ba é Seán an múinteoir  
COP.PAST he.ACC Seán the teacher  
“Sean was the teacher”

Copular sentences also exhibit different word order than other finite clauses. Irish is strictly VSO, but copular sentences are subject final when the predicate is not definite:

- (21) a. Is Sasanaigh iad  
COP.PRES English.PL them.ACC  
“They are English”

- b. Ba dochtúir é  
 COP.PAST doctor he.ACC  
 “He was a doctor”

It is quite clear that the copula is different from other Irish verbs, suggesting that it is not a verb at all. Traditional Irish grammars describe the copula as a ‘preverbal particle,’ but this is not sufficiently specific when we consider the other words included in this category: negative markers, interrogative markers, negative interrogative markers, complementizers, wh-words, etc. Various attempts (McCloskey 2001, Roberts 2004, etc.) have been made to analyze these particles in the context of the left periphery.<sup>11</sup> So what is it? There is a tradition of treating it as a functional head; Doherty (1996) treats it an overt realization of I (=T).

Doherty (1996) points out there is good reason to do so. Preverbal particles in Irish often distinguish between present/future and past tense; Figure 4.10 provides examples:

	pres/fut	past
interrogative	<i>an</i>	<i>ar</i>
negation	<i>ní</i>	<i>níor</i>
subordination	<i>go</i>	<i>gur</i>

Figure 4.10: Tensed preverbal particles in Irish

In sentences with a preverbal particle and a tensed lexical verb, the preverbal particle agrees with the verb:

- (22) a. Níor ghortaigh sé éinne ariamh  
 NEG.PAST hurt.1SG.PRET.IND he anyone ever  
 “He never hurt anyone”

<sup>11</sup>For a wide selection of discussions of the left periphery in general, see Rizzi (1997, 2004) for bibliographies.

- b. Ní tiomáinteann sí  
NEG.PRES drive.3SG.PRES.IND. she  
“She doesn’t drive”
- c. an seomra ar chodail mé ann  
the room that.PAST sleep.1SG.PRET.IND I there  
“the room that I slept in”
- d. an seomra a codladhaim mé ann  
the room that.PRES sleep.1SG.PRES.IND I there  
“the room that I sleep in”

In contrast, the copula cannot co-occur with other preverbal particles, even if they agree:<sup>12</sup>

- (23) a. An (\*is) as Éirinn thú  
Q.PRES COP.PRES from Ireland you  
“Are you from Ireland?”
- b. Ar (\*ba) bhádóir é  
Q.PAST COP.PAST boatman him  
“Was he a boatman?”
- c. ... go (\*is) as Éirinn thú  
... that.PRES COP.PRES from Ireland you  
“... that you are from Ireland”
- d. ... gur (\*ba) bhádóir é  
... that.PAST COP.PAST boatman him  
“... that he was a boatman”

Doherty (1996) argues that in any clause with a preverbal particle, the particle combines with the tense marker, forming a complex tensed particle. If the copula is merely a reflex of an inflectional (I/T) head, then it cannot co-occur with preverbal particles because it combines with them, forming a single phonological unit.

A potential problem is that Irish historically had a purely past-tense particle, *do*, which caused lenition of the following initial consonant; this effect is still seen in Mod-

<sup>12</sup>In Scottish Gaelic, the past-tense copula can co-occur with other preverbal particles.

ern Irish on the past-tense forms of lexical verbs:

- (24) a. mhol sé (cf. *mol*, ‘praise’)  
praised he  
“He praised”
- b. d’ól sé (cf. *ól*, ‘drink’)  
drank he  
“He drank”
- c. bhí an bosca folamh (cf. *bí*, ‘be’)  
was the box empty  
“The box was empty”

However, I propose that *do* does not preclude analyzing the copular particles as overt realizations of T. Following Doherty, I propose that the Irish copular particles, *is* and *ba*, are overt realizations of the T head.

Like Polish, Irish has multiple variants of T. The complete T head assigns Nominative Case to the subject and may be specified for the full range of tense and mood (i.e. preterit, imperfect, etc.). It selects PrP complements which themselves select verbal complements with full verbs, including the existential *bí*, which functions as a raising verb much like *być* can in Polish. Sentences with *bí* are Pure Small Clause copular structures.

Definite sentences with a copular particle, on the other hand, are Equative Small Clause copular structures. They contain a deficient T head, which may be specified for a limited range of tense (i.e. present/future or past/conditional), which lacks a [+V] feature, and which cannot assign Nominative Case to the subject. It takes as a complement a PrP without a verb, and whose Pr head can assign Accusative Case to the subject (see Section 3.1 for discussion). There is no direct way to assess whether the predicate XP in Irish has Accusative or Nominative Case because there is no overt morphological



difference. It is reasonable to assume Accusative Case to assure case match between subject and predicate, which as we saw in Section 4.1 is to be expected of Equative Small Clauses.<sup>13</sup>

Two interesting questions remain. In Irish, indefinite nominal predicates are strictly NPs, not full DPs. Indefinite predicates Move to a relatively high position to the left of the subject (see (21) for examples), whereas definite predicates do not (see (20) for examples). To maintain copula-initial word order, the copular particle must Move into the left periphery.<sup>14</sup> Such Movement does not resolve the definite/indefinite dichotomy.

Additionally, although Irish and Polish both have overt T particles that surface in identity relations, Polish allows definite and indefinite predicate DPs to combine with their subjects in various ways (see Section 4.1). Irish, on the other hand, has restrictions on how predicate DPs can combine with their subjects and have distinct word orders. (25-a) shows word order in a copular sentence with a definite DP; (25-b) shows word order in a copular sentence with an indefinite DP:

---

<sup>13</sup>Bowers (2010) argues that the corresponding verb and particle in Scottish Gaelic are base-generated in different positions, but the similarity ends there. For Bowers, it is the copula that is generated as a lexical verb, whereas the verb *bi* is generated as an overt Voi head. His argument relies on differences between individual- and stage-level predicates, a topic I have not addressed in this thesis. There have been other attempts to explain the semantics of small clauses and copular clauses syntactically. Moro (1997) argues that all copular clauses have the same structure, with *be* a reflex of T, and different semantic interpretations (predicational and specificational) are coerced depending on whether the subject or the predicate of the small clause raises to spec-TP. Rothstein (2001), also argues that *be* is a reflex of T and that the complement of *be* is a small clause, argues that predicational and equative copula sentences have entirely different structures – the small clause of a predicational copular sentence does not have a mediating functional head, but the small clause of an equative copular sentence does. Basilico (2003) argues that small clauses with stage-level predication are embedded within a Topic phrase containing an event argument, whereas small clauses with individual-level predication are not. Citko (2008) argues in Polish, the predicate of a pronominal or dual copula construction (i.e. a construction with her version of the defective Pr head) receives only an individual-level interpretation, whereas predicates embedded under a complete Pr head are not so restricted. Beyond my argument that the subject of every small clause is generated in the same structural position, I remain agnostic about the semantics of small clauses and copular clauses.

<sup>14</sup>See Carnie and Harley (1996) for extensive discussion.

- (25) a. Is é Seán an múinteoir  
COP him Seán the teacher.  
“Sean is the teacher.”
- b. Is fear é  
COP man him  
“He is a man.”

It is unclear why Polish and Irish would have such notable differences in how subjects and predicates combine in copular sentences. I leave both of these questions for future research.

## CHAPTER 5

### CONCLUSION

This thesis has been an attempt to present a unified account of small clauses cross-linguistically and to incorporate my findings into a larger model of tensed clauses.

We can account for the data in all of the languages that I have discussed in depth (English, Russian, Irish, Polish and Chinese) if we assume that small clauses are the same size cross-linguistically, PrP. Different syntactic phenomena result from different properties of the Pr head and T head in each language.

In English and Chinese, the Pr head may be null or overt (*as*, *wei*). The head is defective in that it has no phi-features and cannot assign Case. It has no visible effects on the predicate or the subject. However, it is a feature of verbs in these languages that they can select for null or overt Pr heads in their PrP complements. Thus, in English, the small clause complement of *make* always has a null Pr head; the small clause complement of *regard* always has an overt Pr head; and the small clause complement of *consider* may optionally have a null or overt Pr head. In Chinese, the small clause complement of *jiao* ('call') can never have an overt Pr head, but the complement of *cheng* ('call') optionally can.

In Russian there is a visible syntactic difference between the overt and null Pr heads. The overt Pr head only occurs with predicates that have Instrumental Case, and the null Pr head only occurs with predicates whose Case matches the the subject's. It appears that there are no restrictions on which type of Pr head can occur with different matrix verbs.

In Polish there is a phonetically overt but syntactically defective Pr head, *być*, which occurs in instances of subject-predicate case- and category-match; and a phonetically

null but syntactically complete Pr head, which does not require case- or category-match between subject and predicate. The various combinations of these Pr heads with T heads determines the range of copular sentences in Polish (although one of these structures, the Pure Equative copula, does not contain a true small clause as structurally defined in this thesis, a PrP).

In Irish, the Pr head can assign inherent Case to its specifier in the absence of another Case assigner, which means that PrP can serve as a sentence on its own without projecting TP. We can account for the range of copular sentences in Irish if we combine PrP with different T heads.

Despite these functional and surface differences, small clauses have the same structure in every language that has them. In fact, according to this analysis, all languages have small clauses, because a small clause is merely a PrP – a functional projection that mediates between a subject and predicate, and provides a structural position where subjects are generated. Even if a language does not have small clause complements of the type we see frequently in English (e.g. *Harold considers [Marian a challenge]*), all tensed clauses contain PrP embedded within TP. Many more languages allow PrP complements to copular verbs. We should expect to observe syntactic phenomena beyond what we have seen in English, Russian, Irish, Chinese and Polish. The elegance of the analysis presented here is that it can capture a huge range of syntactic behavior in typologically diverse languages, simply by altering the content of the Pr head.

## BIBLIOGRAPHY

- Adger, D. and Ramchand, G. (2003). Predication and equation. Linguistic Inquiry, **34**, 325–359.
- Attia, M. A. (2005). Functional and anaphoric control in Arabic. ParGram Fall Meeting, Gotemba, Japan.
- Bailyn, J. and Citko, B. (1999). The morphology of Slavic predicates. In Proceedings of FASL 8. Michigan Slavic Publications.
- Bailyn, J. F. (2001a). Overt predicators. Journal of Slavic Linguistics, **9**.
- Bailyn, J. F. (2001b). The syntax of Slavic predicate case. In ZAS Occasional Papers in Linguistics, pages 1–26. Zentrum für Allgemeine Sprachwissenschaft.
- Baker, M. and Vinokurova, N. (2009). On tense and copular verbs in Sakha. Rutgers Working Papers.
- Baker, M. C. (2003). Lexical categories: Verbs, nouns, and adjectives. Cambridge University Press.
- Basilico, D. (2003). The topic of small clauses. Linguistic Inquiry, **34**(1), 1–35.
- Benmamoun, E. (2008). Clause structure and the syntax of verbless sentences. In M.-L. Z. Robert Freidin and C. Otero, editors, Foundational Issues in Linguistic Theory: Essays in Honor of Jean-Roger Vergnaud. MIT Press.
- Bilous, R. (2011). Determiners: Universals and variation [review]. The Canadian Journal of Linguistics, **56**, 128–130.
- Bondaruk, A. (2006). The licensing of subjects and objects in Irish non-finite clauses. Lingua, **116**(6), 874–894.

- Borsley, R. D. (1986). Prepositional complementizers in Welsh. Journal of Linguistics, **22**, 67–84.
- Borsley, R. D. (1989). An HPSG approach to Welsh. Journal of Linguistics, **25**, 333–354.
- Borsley, R. D. (1999). Mutation and constituent structure in Welsh. Lingua, **109**, 267–300.
- Borsley, R. D. (2011). Apparent filler-gap mismatches in Welsh. Essex Research Reports in Linguistics, **61**(1).
- Bowers, J. (1997). A binary analysis of resultatives. In R. C. Blight and M. J. Moosally, editors, The Syntax and Semantics of Predication, volume 38 of Proceedings of the Texas Linguistic Society Conference, pages 43–58. Texas Linguistics Forum, University of Texas at Austin.
- Bowers, J. (2001). Predication. In M. Baltin and C. Collins, editors, The Handbook of Contemporary Syntactic Theory, chapter 10, pages 299–333. Blackwell.
- Bowers, J. (2002). Transitivity. Linguistic Inquiry, **33**(2), 183–224.
- Bowers, J. (2010). Arguments as Relations. MIT Press.
- Bowers, J. S. (1993). The syntax of predication. Linguistic Inquiry, **24**(4), 591–656.
- Carnie, A. (1997). Two types of non-verbal predication in Modern Irish. Canadian Journal of Linguistics, **42**(1-2), 57–73.
- Carnie, A. and Guilfoyle, E., editors (2000). The Syntax of Verb Initial Languages. Oxford University Press.
- Carnie, A. and Harley, H. (1996). Nominally complex copular constructions. In Proceedings of Langue et Grammaire 1. Université de Paris.

- Carrier, J. and Randall, J. H. (1992). The argument structure and syntactic structure of resultatives. Linguistic Inquiry, **23**(2), 173–234.
- Chomsky, N. (1981). Lectures on Government and Binding. Foris.
- Chomsky, N. (1986). Barriers. MIT Press.
- Chomsky, N. (1993). A minimalist program for linguistic theory. In K. L. Hale and S. J. Keyser, editors, Building 20: Essays in Linguistics in Honor of Sylvain Bromberger, pages 1–52. MIT Press.
- Chomsky, N. (1994). Bare phrase structure. MIT Occasional Papers in Linguistics, **5**.
- Chomsky, N. (1995). The Minimalist Program. MIT Press.
- Chomsky, N. (1999). Derivation by phase. MIT Occasional Papers in Linguistics, **18**.
- Chomsky, N. and Lasnik, H. (1977). Filters and control. Linguistic Inquiry, **8**, 425–504.
- Chung, S. and McCloskey, J. (1987). Government, barriers, and small clauses in Modern Irish. Linguistic Inquiry, **18**(2), 173–237.
- Citko, B. (2008). Small clauses reconsidered: Not so small and not all alike. Lingua, **118**, 261–295.
- Contreras, H. (1987). Small clauses in Spanish and English. Natural Language & Linguistic Theory, **5**(2), 225–243.
- Déchaine, R.-M. (1991). Bare sentences. In S. K. Moore and A. Z. Wyner, editors, Proceedings of Salt 1.
- den Dikken, M. (2006). Realtors and Linkers: The Syntax of Predication, Predicate Inversion and Copulas. MIT Press.

- Doherty, C. (1996). Clausal structure and the Modern Irish copula. Natural Language & Linguistic Theory, **14**, 1–46.
- Eide, K. M. and Áfarli, T. A. (1999). The syntactic disguises of the predication operator. Studia Linguistica, **53**, 155–181.
- Embick, D. (2004). On the structure of resultative participles in English. Linguistic Inquiry, **35**(3), 355–392.
- Gair, J. W. and Paolillo, J. (1998). Sinhala nonverbal sentences and argument structure. In B. C. Lust, editor, Studies in South Asian Linguistics: Sinhala and Other South Asian Languages. Oxford University Press, New York. Originally published 1988.
- García, F. G. (1997). A modality view of predicate selection in small clauses. In R. C. Blight and M. J. Moosally, editors, The Syntax and Semantics of Predication, volume 38 of Proceedings of the Texas Linguistic Society Conference, pages 103–111. Texas Linguistics Forum, University of Texas at Austin.
- Gensler, O. D. (2002). Why should a demonstrative turn into a preposition? The evolution of Welsh predicative *yn*. Language, **78**, 710–764.
- Ghomeshi, J. and Massam, D. (2011). The proper D connection. In J. Ghomeshi, I. Paul, and M. Wiltschko, editors, Determiners: Universals and Variation, pages 67–96. John Benjamins.
- Hendrick, R. (1996). Some syntactic effects of suppletion in the Celtic copulas. In R. D. Borsley and I. Roberts, editors, The Syntax of the Celtic Languages: A Comparative Perspective, pages 75–96. Cambridge University Press.
- Heycock, C. (1992). Layers of predication and the syntax of the copula. Belgian Journal of Linguistics, **7**, 95–123.



- Higginbotham, J. (1985). On semantics. Linguistic Inquiry, **16**(4), 547–593.
- Hornstein, N. and Lightfoot, D. (1984). Rethinking predication. ms., University of Maryland.
- Hornstein, N. and Lightfoot, D. (1987). Predication and pro. Language, **63**(1), 23–52.
- Kayne, R. (1984). Connectedness and Binary Branching. Foris.
- Kim, S. and Maling, J. (1997). A crosslinguistic perspective on resultative formation. In R. C. Blight and M. J. Moosally, editors, The Syntax and Semantics of Predication, volume 38 of Proceedings of the Texas Linguistic Society Conference, pages 189–204. Texas Linguistics Forum, University of Texas at Austin.
- Kitagawa, Y. (1985). Small but clausal. Papers from the Regional Meeting of the Chicago Linguistic Society, **21**, 210–220.
- Koopman, H. and Sportiche, D. (1991). The position of subjects. Lingua, **85**, 211–258.
- Kreps, C. (1994). Another look at small clauses. UCL Working Papers in Linguistics, **6**, 149–177.
- Lambrecht, K. (1997). French relative clauses as secondary predicates. In R. C. Blight and M. J. Moosally, editors, The Syntax and Semantics of Predication, volume 38 of Proceedings of the Texas Linguistic Society Conference, pages 205–221. Texas Linguistics Forum, University of Texas at Austin.
- Larson, R. (1988). On the double object construction. Linguistic Inquiry, **19**, 335–391.
- Lasnik, H. (1995). Case and expletives revisited: On greed and other human failings. Linguistic Inquiry, **26**, 615–633.
- Lundin, K. (2003). Small Clauses in Swedish: Towards a Unified Account. Ph.D. thesis, Lund University.

- Manzini, M. R. (1998). Syntactic approaches to cliticization. Glott International, 3(3), 3–7.
- Marelj, M. and Matushansky, O. (2009). Against overt predicators in Slavic. In Syntax and Ontology of Predication Workshop. Université Paris.
- Matushansky, O. (2006). Predication: A case study. In Formal Description of Slavic Languages, volume 6. Nova Gorica Polytechnic.
- McCloskey, J. (2001). The morphosyntax of wh-extraction in Irish. Journal of Linguistics, 37, 67–100.
- McCloskey, J. (2005). A note on predicates and heads in Irish clausal syntax. In A. Carnie, S. A. Dooley, and H. Harley, editors, Verb First: On the Syntax of Verb-Initial Languages. John Benjamins.
- Moro, A. (1997). The Raising of Predicates: Predicative Noun Phrases and the Theory of Clause Structure. Cambridge University Press.
- Ó Siadhail, M. (1989). Modern Irish: Grammatical Structure and Dialectal Variation. Cambridge University Press.
- Ouali, H. (2005). Verb movement and object pronominal clitic distribution in Berber.
- Partee, B. (1986). Amiguous pseudoclefts with unambiguous ‘be’. In B. Berman, J.-W. Choe, and J. McDonough, editors, Proceedings of NELS 16, pages 354–366.
- Pesetsky, D. (1982). Paths and Categories. Ph.D. thesis, MIT.
- Pollock, J.-Y. (1989). Verb movement, universal grammar, and the structure of ip. Linguistic Inquiry, 20(3), 365–424.
- Radford, A. (2004). English Syntax: An Introduction. Cambridge University Press.

- Rafel, J. (1998). Complex small clauses. U. Penn Working Papers in Linguistics, **5**(1).
- Rizzi, L. (1997). The fine structure of the left periphery. In L. Haegeman, editor, Elements of Grammar: Handbook of Generative Syntax. Kluwer.
- Rizzi, L., editor (2004). The Structure of CP and IP. Oxford University Press.
- Roberts, I. (1994). Two types of head movement in Romance. In D. Lightfoot and N. Hornstein, editors, Verb Movement. Cambridge University Press.
- Roberts, I. (2004). The C-System in Brythonic Celtic languages, V2, and the EPP. In L. Rizzi, editor, The Structure of CP and IP. Oxford University Press.
- Rothstein, S. (1997). Predicational “be”. In R. C. Blight and M. J. Moosally, editors, The Syntax and Semantics of Predication, volume 38 of Proceedings of the Texas Linguistic Society Conference, pages 281–293. Texas Linguistics Forum, University of Texas at Austin.
- Rothstein, S. (2001). Predicates and Their Subjects. Kluwer, Dordrecht.
- Rouveret, A. (1996). *Bod* in the present tense and in other tenses. In R. D. Borsley and I. Roberts, editors, The Syntax of the Celtic Languages: A Comparative Perspective, pages 125–170. Cambridge University Press.
- Safir, K. (1983). On small clauses as constituents. Linguistic Inquiry, **14**(4), 730–735.
- Shlonsky, U. (1997). Clause Structure and Word Order in Hebrew and Arabic: An Essay in Comparative Semitic Syntax. Oxford University Press.
- Stalmaszczyk, P. (1999). Structural predication in generative grammar. Wydawnictwo Uniwersytetu Łódzkiego.
- Stowell, T. (1978). What was there before there was there? In D. Farkas, editor, Proceedings of the 14th Regional Meeting of the Chicago Linguistic Society.

- Stowell, T. (1981). Origins of Phrase Structure. Ph.D. thesis, MIT.
- Stowell, T. (1983). Subjects across categories. The Linguistic Review, **2**(3), 285–312.
- Tallerman, M. (1996). Fronting constructions in Welsh. In R. D. Borsley and I. Roberts, editors, The Syntax of the Celtic Languages: A Comparative Perspective, pages 97–124. Cambridge University Press.
- Tang, S.-W. (1998). Parametrization of Features in Syntax. Ph.D. thesis, University of California, Irvine.
- Uriagereka, J. (1999). Multiple spell-out. In S. Epstein and N. Hornstein, editors, Working Minimalism, pages 251–282. MIT Press.
- Wechsler, S. (1997). Resultative predicates and control. In R. C. Blight and M. J. Moosally, editors, The Syntax and Semantics of Predication, volume 38 of Proceedings of the Texas Linguistic Society Conference, pages 307–321. Texas Linguistics Forum, University of Texas at Austin.
- Williams, E. (1975). Small clauses in English. In J. Kimball, editor, Syntax and Semantics, volume 4. Academic Press.
- Williams, E. (1980). Predication. Linguistic Inquiry, **11**(1), 203–238.
- Williams, E. (1983). Against small clauses. Linguistic Inquiry, **14**(2), 287–308.
- Williams, E. (1997). The asymmetry of predication. In R. C. Blight and M. J. Moosally, editors, The Syntax and Semantics of Predication, volume 38 of Proceedings of the Texas Linguistic Society Conference, pages 323–333. Texas Linguistics Forum, University of Texas at Austin.
- Williams, E. (2010). Island fever. In Structure Preserved: Studies in Syntax for Jan Koster. John Benjamins.