

Heating with Wood and Coal

Revised by

John W. Bartok, Jr.

Extension Professor Emeritus

Department of Natural Resources Management and Engineering
University of Connecticut

Based on the 1985 Revision of *Burning Wood and Coal*

by

Susan MacKay

L. Dale Baker

John W. Bartok, Jr.

James P. Lassoie

Natural Resource, Agriculture, and Engineering Service (NRAES)
Cooperative Extension • PO Box 4557
Ithaca, New York 14852-4557

NRAES-23
December 2003 Revision

©2003 by NRAES—Natural Resource, Agriculture, and Engineering Service
All rights reserved. Inquiries invited. (607) 255-7654

ISBN 0-935817-91-3

Library of Congress Cataloging-in-Publication Data

Heating with wood and coal / revised by John W. Bartok, Jr.—2003 revision.
p. cm. — (NRAES ; 23)
Rev. ed. of: Burning wood and coal. c1985.
Includes bibliographical references.
I. Bartok, John W., 1936– II. Burning wood and coal. III. NRAES (Series) ; 23.

TP324.H43 2003
697-dc22

2003064869

Requests to reprint parts of this book should be sent to NRAES. In your request, please state which parts of the book you would like to reprint and describe how you intend to use the reprinted material. Contact NRAES if you have any questions.

Natural Resource, Agriculture, and Engineering Service (NRAES)
Cooperative Extension
PO Box 4557
Ithaca, New York 14852-4557

Phone: (607) 255-7654 • Fax: (607) 254-8770
E-mail: NRAES@CORNELL.EDU • Web site: WWW.NRAES.ORG

Contents

Introduction.....	1
Chapter 1: Evaluating Solid Fuels	3
Advantages and Disadvantages.....	3
Wood, Coal, or Other Solid Fuel?.....	3
Comparing Heating Fuel Costs.....	5
Combustion Basics.....	7
Combustion of Wood	8
Combustion of Coal	8
Efficiency	9
Pollution and Air Quality	10
Chapter 2: Fireplaces	13
Chapter 3: Stoves	17
Stove Size.....	17
Materials of Construction	17
Stove Types.....	17
Coal Stove Design.....	20
Chapter 4: Furnaces and Boilers.....	23
Central Heating Options	23
Features	25
Chapter 5: Installation.....	27
Stove Testing and Certification	27
Stove Clearances.....	27
Floor Protection	27
Wall Protection.....	28
Furnace Duct Clearances	28
Stovepipe.....	28
Unlisted Stove Installation Checklist.....	32
Chapter 6: Chimneys.....	33
Factors Affecting the Draft	33
Chimney Types	33

Chimney Requirements.....	35
Two or More Connections to One Chimney	35
Chimney Caps	35
Chimney Height	36
Chimney Inspection	36
Chimney Cleaning	36
Heating System Maintenance	37
Chimney Fires.....	38
Chapter 7: Wood as a Fuel	41
Buying Firewood	41
Cutting Your Own Wood.....	43
Characteristics of Wood.....	44
Seasoning and Storing Wood	45
Operating Techniques	47
Creosote	47
Stove Operation	49
Chapter 8: Coal as a Fuel	53
Types of Coal	53
Purchasing Coal	54
Storage	55
Operating Techniques	56
Appendix A: Cutting Firewood with a Chainsaw	63
Equipment.....	64
Operation.....	64
Felling	65
Limbing.....	66
Bucking.....	67
Splitting Wood	67
References.....	69
About NRAES	70

Introduction

The energy crisis of 1973, in which fossil fuel supplies were reduced and prices skyrocketed after many years of stability, revived the demand for wood and coal heating appliances.

Looking back in history, wood was the major heat source in the United States until 1890, when it was replaced by coal. Wood sources had become depleted, and the expanding railroads were able to move the large quantities of coal needed. Coal, a more dense fuel with a higher heat value, warmed the country until about 1940 when fossil fuel sources—oil and gas—were developed and the distribution system put into place. Both wood and coal are considered solid fuels. Other less common solid fuels include wood chips, sawdust, pellets, compressed paper, and corn. Solid-fuels usage rapidly decreased to a small percentage of the total fuel usage, as most people enjoyed the convenience of the new heating systems.

After 1973, fossil fuel prices increased rapidly, with fuel oil jumping from about 12 cents per gallon to over \$1 per gallon in a few short years. This resulted in a new industry with over 1,000 manufacturers making wood and coal stoves for household heating. Since that time, the industry has gone through several boom-bust cycles. The finding of new fossil fuel supplies, environmental and safety concerns with solid fuels, and altering lifestyles influenced sales of wood and coal stoves. Today there are only about fifty manufacturers left.

This book is being updated at a time when fossil fuel supplies and pricing have been very volatile, unemployment on the increase, and the economy waning. Interest in solid fuels is again beginning to pick up. This book reflects technology and code changes affecting the installation of stoves that have occurred since 1985, when the last edition of this book, then

entitled *Burning Wood and Coal*, was published.

This book is designed to be used as a guide when selecting, installing, and operating a solid-fuel stove for home heating. It offers the pros and cons of wood and coal as fuels; helps you evaluate your needs and decide on available equipment options; gives specifics on stove installation; and tells you how to keep your heating system maintained for top performance. The appendix gives detailed information about harvesting, seasoning, and storing wood.

Safety and automated combustion features, which are part of oil and gas furnaces, allow you to set the thermostat and forget it. With wood- or coal-burning stoves, a much greater awareness of fuel characteristics and combustion techniques is required to use the fuel efficiently and safely and to prevent the emission of large quantities of pollutants into the air. Newer designs for catalytic and noncatalytic woodstoves have overcome part of this problem. Furnaces and boilers with power drafts operate almost like fossil-fuel units in that when the need for heat stops, the draft is shut down, and the fire idles.

As the installation of all heating appliances requires a building permit, it is important that one be obtained before an installation is made. With the guidance of this book, the installation manual, and the building official, you can have an efficient, safe, rewarding installation that will provide heat to your home for many years.

Both wood and coal are more difficult to burn at the beginning and end of the heating season without overheating the home. The draft on the stove has to be closed down to the point where the fire goes out. During this period of time, the primary heating system in the home—oil, gas, or electricity—may be used full time.

Coal and pellet stoves with gravity-feed hoppers require little attention. Coal furnaces or boilers with stokers can be almost completely automated, making the heating system almost as easy to operate as with oil or gas.

Before investing in a solid-fuel system, consider upgrading the energy conservation level of your home.

This includes weatherization, insulation levels, and storm windows and doors (figure 1a). These measures usually have a shorter payback than alternate fuel systems and will lower yearly costs. They will also reduce the amount of wood or coal that has to be purchased when you install your stove. Information on these can be found in many books available in bookstores and home centers.

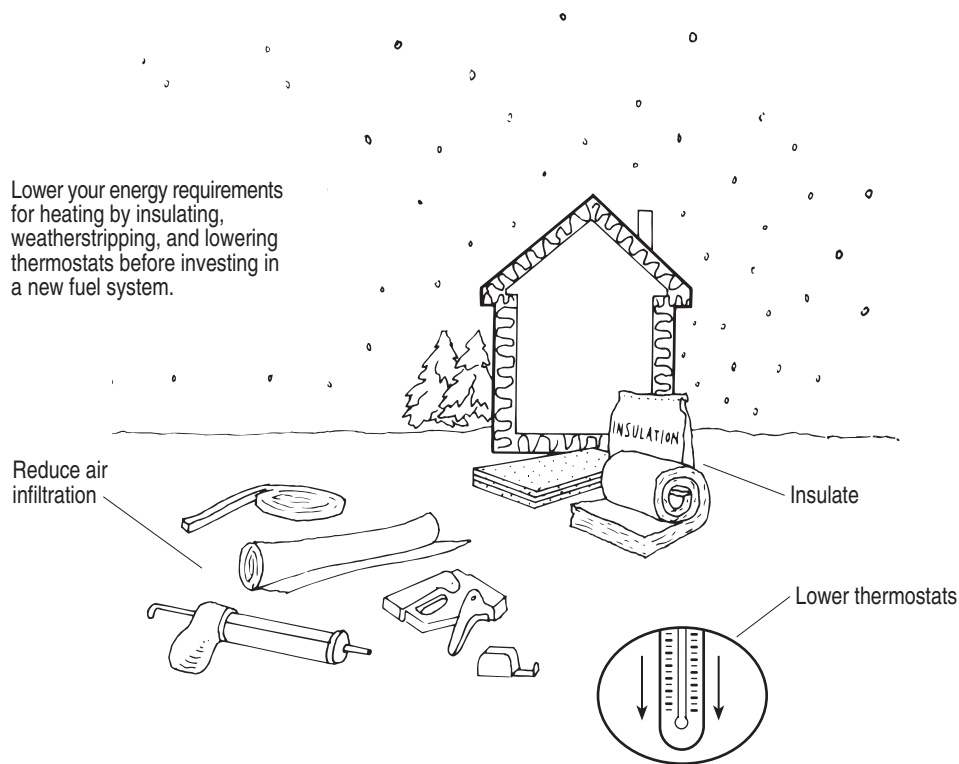

Insulate and Save

Before deciding to alter or replace your present heating system, reduce heat loss in your home as much as possible. Conservation measures can cut former energy use by 30 to 60%. At the same time, a tight house with good insulation makes living conditions more comfortable in winter **and** summer. Insulation investments can be returned within two years and thereafter give you annual savings. No fuel and heating system will be economical in a drafty, poorly insulated house.

Figure 1a. Consider energy conservation first

Chapter 1: Evaluating Solid Fuels

Advantages and Disadvantages

With the recent wide swings in the price of fossil fuels, wood and coal may sometimes be much less expensive and at other times somewhat more expensive. It depends on where you obtain your supply.

Depending on where you live, wood and coal may always be somewhat less expensive than natural gas, oil, and electricity, because they are less convenient to use and do not provide as even and controllable heat output. Heating with solid fuels involves a daily commitment of labor and attention—to store and handle the fuel, tend the fire, and remove the ashes.

Both wood and coal (particularly coal) are difficult to burn efficiently at the beginning and end of winter without overheating the house. Burning solid fuels cannot be fully automated, so without a backup heat system, relying entirely on solid fuels presents the risk of frozen pipes and costly repairs. For these reasons they are often used to supplement an existing system using oil, gas, or electricity.

Wood, Coal, or Other Solid Fuel?

Wood

Wood is more readily available outside of urban areas. But even in rural areas, wood, which was once almost free except for labor, is now becoming expensive and more difficult to obtain. It is important to arrange for a reliable wood supply.

Wood is classified as either hardwood or softwood (see table 7–2, page 45). Since there are so many variables in wood (type of wood, amount of moisture, amount of labor to get it fire-ready, etc.)—and in its “delivered” measurement (cord, face cord, truckload,

etc.)—it pays to shop around. Experienced wood burners and local forestry agencies in your area can often suggest excellent sources of firewood and steer you clear of sources where they have been “burned.”

Purchased wood prices are directly related to the number of times it is handled and the trucking distance. Table 1–1 gives you an idea of how the cost is determined for a cord handled in a conventional manner. Other ways wood can be purchased include:

- Directly in the woods as standing timber
- Four-foot lengths at the farm—you load and deliver
- Tops and cull logs delivered in 20-foot lengths with a logging truck (usually seven or eight cords per load)
- Slabwood from a sawmill
- Scrap wood from a furniture-manufacturing plant

If you own or have access to a woodlot, consider your time or cost to prepare the wood for fuel. Cutting, hauling, and stacking your own wood supply is hard work, time-consuming, and potentially dangerous. On the other hand, some people find the physical exercise, shared family responsibility, and sense of independence relaxing and enjoyable.

Table 1–1. Value added to a cord of firewood at different stages

In the woods	\$5–\$15 *
Cut to 4-foot lengths	\$35–\$45
Delivered to the fuel yard	\$10–\$15
Cut to stove length	\$25
Split	\$10–\$20
Loaded and delivered to home (nearby)	\$20
Seasoning	\$10–\$15

* 2002 Connecticut prices

The moisture content of freshly cut wood can be as high as 60%, so wood must be cut in advance and properly seasoned. It should be stored under cover, either in a woodshed or covered with a tarp or metal roofing. Seasoning may take six months or longer depending on seasonal temperatures and the initial moisture content. Compared to coal or oil, wood is relatively bulky for the amount of heat derived, so a large storage area is needed, unless the wood is in pellet form.

Wood is relatively easy to ignite, so stove designs have been relatively simple. But in the past ten years, many advances have been made in woodstove design to get more heat from the fuel and to reduce creosote and emission problems. The stove, including pipes and chimneys, needs periodic cleaning to remove ash, soot, and creosote.

Coal

Coal, while not renewable, represents approximately 85% of the U.S. fossil fuel reserves. Anthracite (hard coal), the preferred coal for home heating, is available in most parts of the United States. Bituminous coal (soft coal) is used mainly for industrial heating and power generation. The revival of coal burning has not been as rapid or widespread as the revival of wood burning. It is generally turned to for practical reasons, such as its hard-to-beat cost, availability, compactness, and lower labor requirements.

The moisture content of coal is much lower than that of wood, so less heat is wasted to drive off moisture. In addition, creosote does not form during combustion of hard coal. But the kindling temperature of coal (790–975°F) is much higher than that of wood (550°F), so coal fires are harder to start, and more heat must be maintained within the fuel bed to keep the fire burning.

Some mining companies prewash their coal before bagging to reduce the dust. Because coal has a higher ash content than wood (2–3%), the ash pan needs more frequent cleaning. Fly ash and soot in the chim-

ney means regular chimney cleaning to maintain the strong draft necessary for coal burning.

On the other hand, coal is more compact, requiring about one-third the storage space of wood with an equivalent heat value. Coal fires also have a more even heat output than wood fires. Coal is less labor-intensive; the fire will burn for longer periods than a wood fire, without loss of efficiency and potentially dangerous creosote formations. Another advantage of coal furnaces and boilers is that they can be used to burn both coal and wood, whereas wood-burning units can only be used for wood. Coal-burning units can also be more fully automated for fuel loading and ash removal than their wood-burning counterparts. Figure 1–1 illustrates the advantages and disadvantages of burning wood compared to burning coal.

Pellets

Pellets are an environmentally friendly alternative fuel that has been developed since the 1980s. Their use has increased significantly over the past few years due to the availability of better stoves that don't require a conventional chimney, and because they are a more uniform, convenient fuel. Materials such as sawdust, paper, and peanut and sunflower hulls are oven-dried, ground, and screened to a standard size. The material is then pressed into pellets, about $\frac{1}{4}$ inch in diameter and 1– $1\frac{1}{2}$ inches long. They are usually packaged in 40-pound bags and sold through stove dealers, feed stores, and nurseries. They have a low moisture and ash content and a high heat value. The premium grade has less than 1% ash content, and the standard grade less than 3%. Pellets tend to be more expensive than other fuels due to the equipment and energy needed to manufacture them and the transportation cost.

Corn

Corn is also used as fuel. It is shelled from the cob and packaged into bags. Heat value, moisture content, and ash are similar to pellets. Cost can vary depending on

the distance the corn has to be shipped.

Comparing Heating Fuel Costs

The cost of various forms of energy are evaluated in different ways, making comparisons difficult. Figure 1–2 (page 6) will enable you to compare the market value of various heating fuels on the basis of their heating equivalent as expressed in dollars per million British thermal units (\$/MBtu). Heater efficiencies are included in the listed values.

To use the chart, determine the local market value of the fuel you wish to compare, and read across the fuel price columns to the heating equivalent column to determine the price per MBtu.

For example, if anthracite is available for \$120 per ton, the heating equivalent cost is approximately \$8.00 per MBtu. Fuel oil at \$1.10 per gallon has a heating equivalent cost of \$10.60 per MBtu. In this case, it may pay to switch to coal because the cost of coal is significantly lower than the cost of oil.

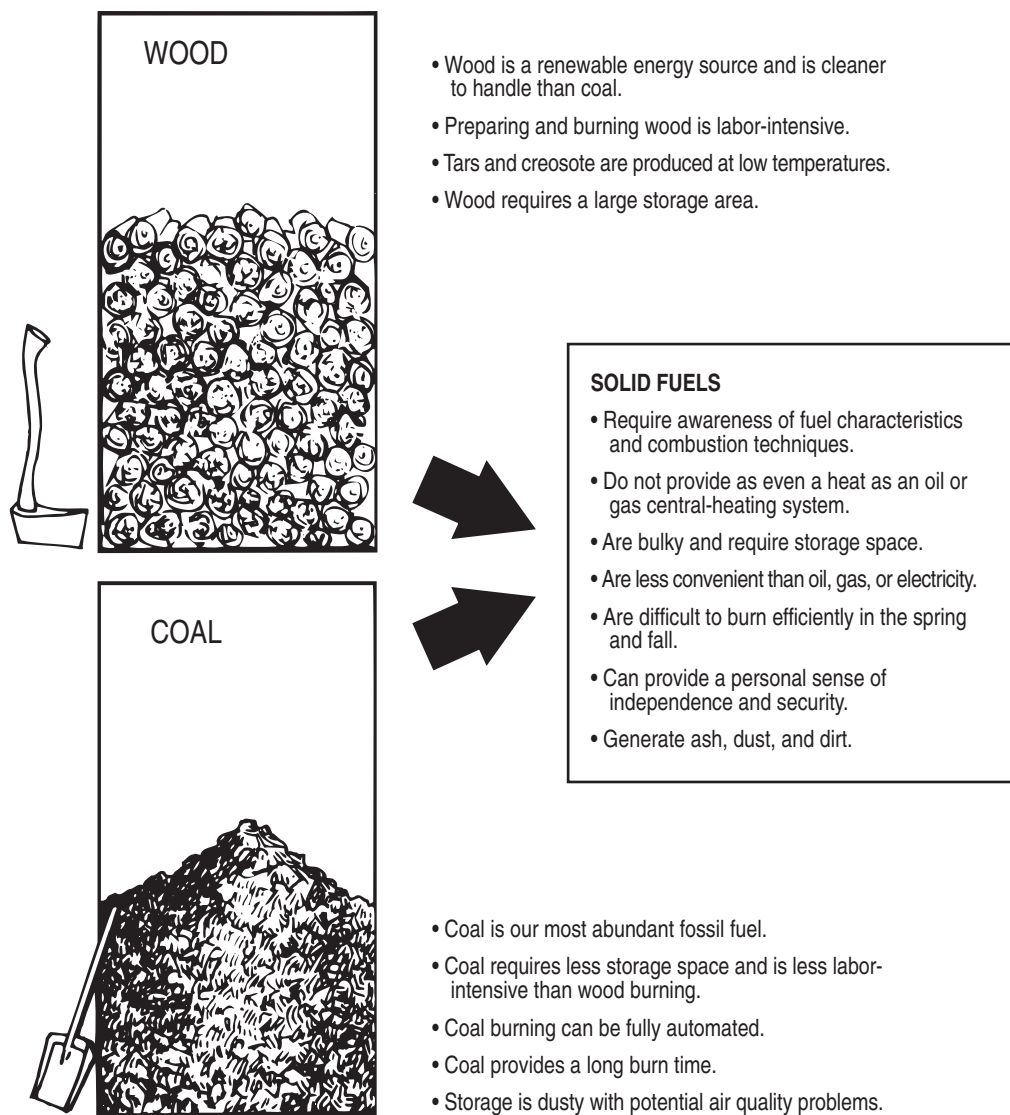
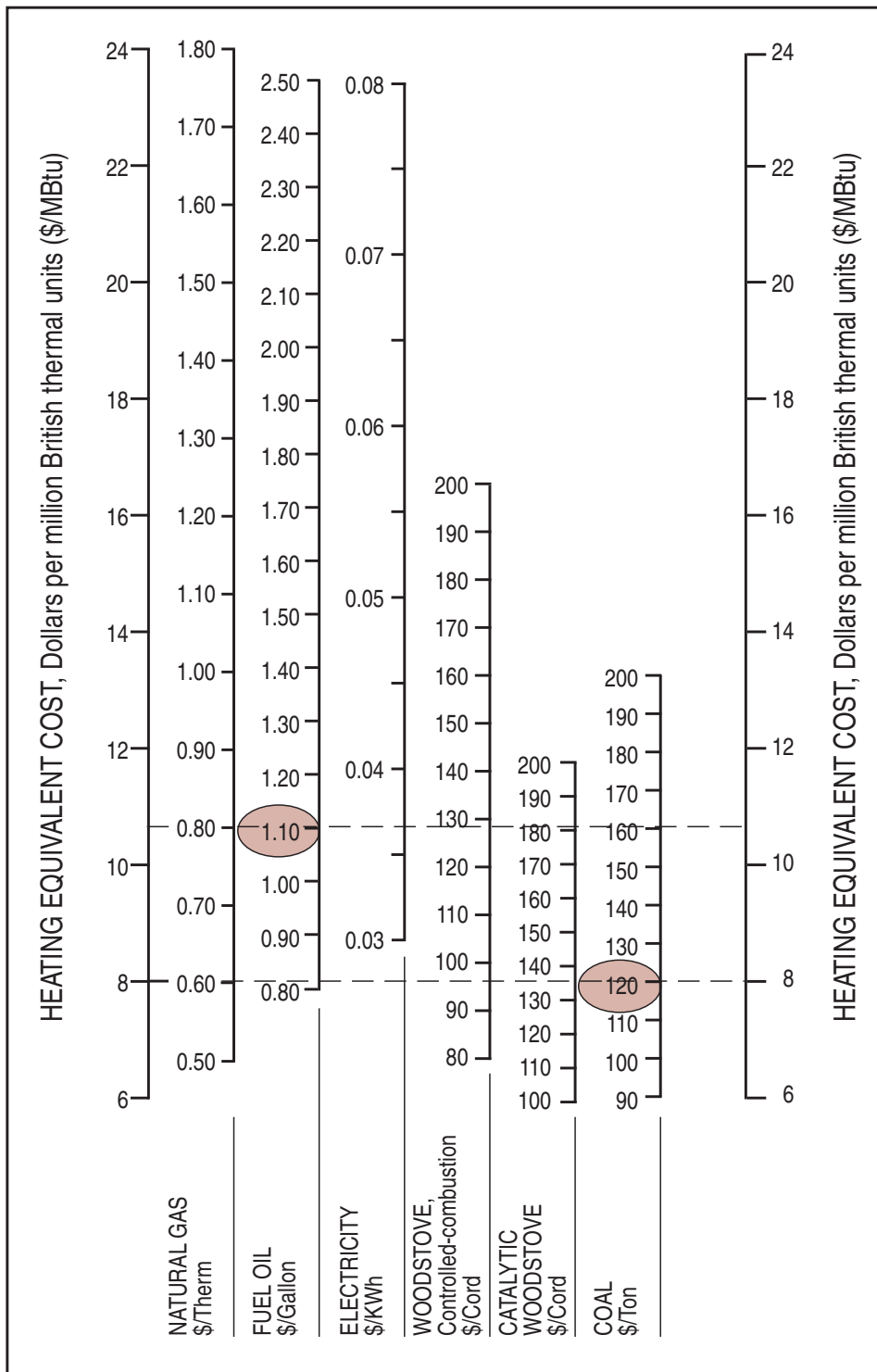

Figure 1–1. Comparing wood and coal



To use this chart, determine the local market value of the fuel you wish to compare, and read across the fuel price columns to the heating equivalent column to determine the price per MBtu.

For example, if anthracite is available for \$120 per ton, the heating equivalent cost is approximately \$8.00 per MBtu. Fuel oil at \$1.10 per gallon has a heating equivalent cost of \$10.60 per MBtu. In this case, it may pay to switch to coal because the cost of coal is significantly lower than the cost of oil.

ASSUMPTIONS

NATURAL GAS—Therm = 100,000 Btu = approximately 100 cubic feet
75% Efficiency \$/MBtu = 13.33 x \$/therm

FUEL OIL—138,000 Btu/gallon
75% Efficiency \$/MBtu = 9.96 x \$/gallon

ELECTRICITY—3,412 Btu/kWh (kilowatt hour)
100% Efficiency \$/MBtu = 293 x \$/kWh

MIXED HARDWOODS (Dry)— 24 MBtu/cord
Controlled-combustion stove:
50% Efficiency \$/MBtu = \$/cord/12
High-efficiency or catalytic woodstove:
70% Efficiency \$/MBtu = \$/cord/17

COAL—12,500 Btu/pound
60% Efficiency \$/MBtu = \$/ton/15

PELLETS or CORN—8,200 Btu/pound
80% Efficiency \$/MBtu = \$/ton/13

Figure 1–2. Comparing heating fuel costs

It is important to determine the total cost of converting the typical home or business to supplemental wood or coal heating. Many economic comparisons consider only relative fuel costs and neglect the expense of purchasing, installing, and maintaining an additional heating unit. For those cutting their own wood, there are equipment costs and personal time involved. At \$10 per hour, a winter's supply of six cords of firewood may be worth about \$720 in an individual's time.

Those considering conversions must be ready for a change in lifestyle. To many, working up a fuel supply and tending a woodstove are enjoyable activities; to others, this is just hard work that detracts from other activities. Those who do convert are making a long-term commitment to paying more attention to their heating needs.

Before purchasing a new solid-fuel system, first decide how it will be used. Consider the total cost of installing a stove. Remember, you may need to buy stovepipe, floor and wall protection, and a chimney as accessories. A complete installation can have an upfront cost of over \$1,000. In determining your economics, consideration for long-term savings must be factored into the equation.

A knowledge of combustion basics and commonly used solid-fuel terms will help you evaluate the options presented in the following chapters on fireplaces,

stoves, and central heating systems.

Combustion Basics

The combustion of wood and coal involves the mixing of carbon and hydrogen from the fuels with oxygen from the air to form carbon dioxide, water, and heat. Combustion has three requirements—fuel, air, and **heat**. If any of these three is removed, burning ceases. When all three are available in the correct proportion, combustion is self-sustaining, because the fuel releases more than enough heat to initiate further burning.

The rate at which wood or coal burns is controlled by the amount of available air. Little or no air causes wood to smolder and produce pollutants, or it stops combustion. Too much air will cool the fire, remove the heat, and essentially blow the fire out.

Another important aspect of combustion is the energy content of the fuel. Energy content is a measure of the available chemical energy per pound and is normally expressed in British thermal units (Btu). Heating value is the amount of heat actually available from a fuel. Heating value will be directly related to the energy content, but other factors, such as moisture content of the fuel, also affect the heating value. Table 1–2 shows heating values for several common fuels.

Table 1–2. Heating value of common fuels

TYPE OF FUEL	BRITISH THERMAL UNITS (BTU)/POUND
Hardwood and softwood, 50% moisture	Approximately 4,700
Hardwood and softwood, 20% moisture	Approximately 6,200
Wood pellets, 10% moisture	Approximately 8,100
Wood chips	Approximately 8,000
Compressed paper	Approximately 8,000
Coal	11,000–14,000
Shelled corn	7,800–8,500
#2 Fuel oil	19,700 (138,000 Btu/gallon)
Natural gas	22,800 (100,000 Btu/therm)
Propane	21,630 (91,700 Btu/gallon)

Combustion of Wood

Combustion transforms wood into heat, chemicals, and gases by the chemical combination of hydrogen and carbon in the fuel with oxygen in the air. Complete combustion produces water vapor and carbon dioxide along with heat and noncombustible ashes. When incomplete combustion occurs, carbon monoxide, hydrocarbons, and other gases are formed. Figure 1–3 illustrates the stages of wood combustion.

Approximately 50–60% of the heat available from burning wood is in the volatile gases. All three phases of burning may occur at the same time. However, the first two phases usually occur when the fire is started or when wood is added. For efficient burning, the volatiles must be mixed with air and kept at a high enough temperature to burn completely inside the heating unit.

Wood varies in size, density, and moisture content; it is not a simple, uniform fuel like natural gas, propane, or fuel oil. Gas and oil can be burned at fairly high efficiencies, because the burner always operates

at full output, and the fuel can easily be started and stopped. Wood-fueled heaters operate most efficiently when they are burning at high temperatures. This also reduces creosote formation in the chimney.

In spring and fall, it is difficult to operate woodstoves at full output to create high enough temperatures for good combustion without overheating the room. If the stove is normally operated at reduced draft in order to achieve a comfortable room temperature, or in order to hold the fire overnight, the efficiency of the stove is decreased.

Combustion of pellets and corn is similar to that of wood with the exception that the fuel has a lower moisture content. Control of the fire is also easier due to the uniform-sized product that can be fed either from a hopper or with an auger.

Combustion of Coal

The combustible portions of coal are fixed carbon, volatile matter (gaseous compounds of hydrogen and carbon), and small amounts of sulfur. Before a mate-



<p>FIRST STAGE</p> 	<p>The wood is heated to evaporate and drive off moisture.</p> <p>This heat does not warm the stove or room.</p>
<p>SECOND STAGE (500°F–1100°F)</p> 	<p>The wood starts to break down chemically at 500°F and volatile matter is vaporized.</p> <p>The vapors contain between 50 and 60% of the heat value of the wood.</p> <p>At 1100°F, these vapors burn. This high temperature must be maintained for maximum efficiency of combustion.</p>
<p>THIRD STAGE (over 1100°F)</p> 	<p>Following the release of volatile gases, the remaining material (charcoal) burns at temperatures exceeding 1100°F.</p>

Figure 1–3. Combustion of wood

rial will ignite with oxygen, its ignition temperature must be reached. The ignition temperature occurs when a fuel starts to change from its solid state to a combustible gas.

This temperature varies with different materials, as shown in table 1–3. Complete combustion means burning all the gases and all of the carbon or solid

Table 1–3. Ignition temperatures of various fuels and combustible gases

FUEL	IGNITION TEMPERATURE (°F) *
Compressed paper	350
Wood and pellets	550
Fuel oil	560
Soft charcoal	650
Cannel coal	668
High-volatile bituminous coal	765
Low-volatile bituminous coal	870
Anthracite	925
Hydrogen	1,031–1,130
Carbon monoxide	1,200–1,292
Propane	914
Methane	1,202
Sulfur	470

*The ignition temperature is the lowest temperature at which burning is self-sustaining.

portion of the fuel that is possible under ordinary conditions. Figure 1–4 illustrates the basic principles of coal combustion.

When coal starts to burn, volatile matter is driven off. This may take only a few minutes with anthracite, slightly longer with low-volatile bituminous coal, or ten to fifteen minutes with softer coals. Volatile matter does not exist in coal, as such, but it is produced by the decomposition of coal when heated. It consists chiefly of the combustible gases—hydrogen, carbon monoxide, methane and other hydrocarbons, tar vapors, volatile sulfur compounds, and some noncombustible gases, such as carbon dioxide and water vapor.

Ignition of the volatiles takes place above the fuel bed. It requires a high enough temperature for the gases to ignite and a sufficient quantity of oxygen to complete their combustion.

Efficiency

Efficiency is the percentage or fraction of chemical energy available from the fuel that heats the room. Efficiency depends on the fuel used, the skill of the

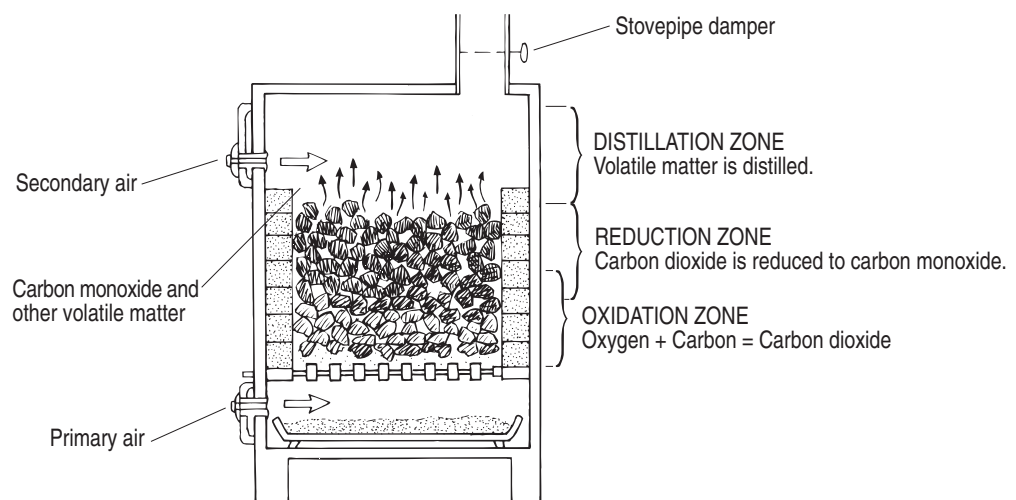

Figure 1–4. Combustion of coal

operator, and the design of the stove and chimney.

For a stove to have high overall energy efficiency, it must perform two jobs well. First, the fuel must be burned as completely as possible so very little smoke goes out the chimney (combustion efficiency). Second, the stove must transfer the heat in the stove to the room (heat transfer efficiency).

Increased heater efficiency has been a major concern of most solid-fuel stove manufacturers. In addition to burning less fuel for a given amount of heat, efficient stoves produce fewer emissions and less creosote. However, the lack of consistent rating methods among manufacturers makes comparisons difficult for the consumer. Table 1–4 shows the range of energy efficiencies you can expect from various types of available solid-fuel burners.

Pollution and Air Quality

Continued improvement in the efficiency of woodstoves has significantly reduced the amount of pollu-

tion generated to less than 15% of that produced by older conventional stoves. Woodstoves manufactured since July 1988 have had to meet standards set by the U.S. Environmental Protection Agency (EPA), which limit the amount of particulate matter that can be emitted. They must also have an air-to-fuel ratio of less than 35:1, a firebox volume less than 20 cubic feet, and a minimum burn rate of less than 11 pounds of wood per hour.

Wood burned in a hot fire creates very little smoke. What you are left with is carbon dioxide, some carbon monoxide, a number of other gases, bits of partially oxidized hydrocarbons, and water vapor. An added benefit is an increase in the amount of heat that is obtained from the wood.

Wood smoke from a smoldering fire contains, among other things, carbon monoxide, nitrogen oxides, methane, formaldehyde, and particulates, or solid unburned hydrocarbons.

Incomplete combustion of coal can release carbon monoxide, other volatile gases, and particles of carbon into the atmosphere. Burning anthracite is essentially much cleaner than burning wood in terms of potential for atmospheric pollution, since anthracite has a very low sulfur content. Soft coal, particularly high-volatile bituminous coal, has much greater potential for pollution than anthracite, which usually contains less than 8% volatile matter (figure 1–5).

Certain meteorological conditions, such as severe temperature inversions, aggravate problems associated with stove emissions. In this condition, an upper layer of warm air traps a lower layer of colder air and smoke, reducing visibility and creating health hazards (figure 1–6, page 12). In some areas, notably Montana, Oregon, and Colorado, communities with recurrent air pollution problems have restricted the types of woodstoves homeowners may install, or they have imposed stringent fines for burning wood when air-monitoring devices indicate high pollution levels.

Table 1–4. Energy efficiency for various heating units

TYPE OF HEATING UNIT	EFFICIENCY RANGE
Masonry, manufactured or freestanding fireplace	–10%–20%
Fireplace with heat exchanger and outside combustion air	10%–30%
Modular concrete heat-storing fireplace	35%–40%
Fireplace with “airtight” stove insert	35%–50%
“Airtight” stove	50%–70%
“Airtight” stove with add-on catalytic converter	55%–70%
Catalytic stove	65%–75%
Pellet stove	75%–85%
Wood furnace	50%–70%
Gas or oil-fired furnace	65%–85%
Electrical heat	100%

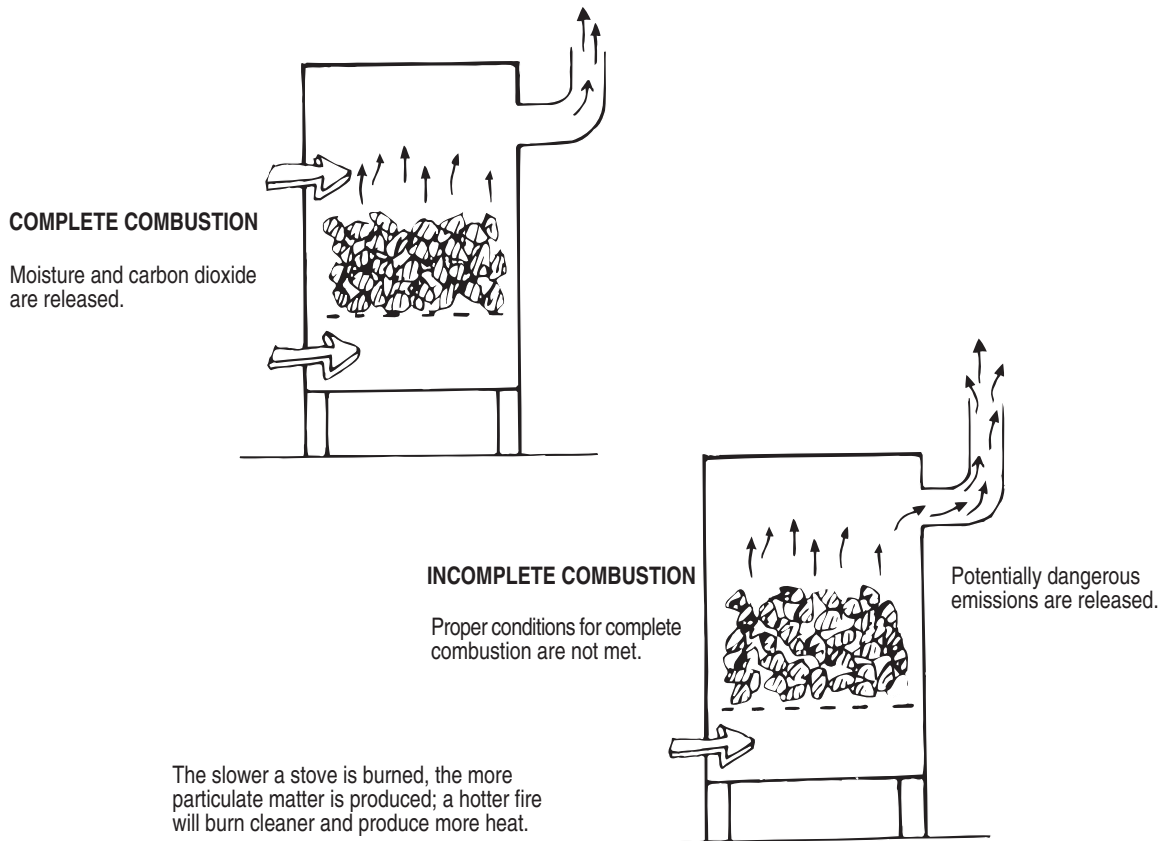

PARTICULATE MATTER (Soot)

Particulates produce pollution, which reduces visibility, smells bad, and reduces heating system efficiency.

1. LARGE AIRBORNE PARTICLES of carbon can be caught in the nostrils and upper respiratory system.
2. TINIER AIRBORNE PARTICLES of carbon are more dangerous, since they lodge in the lungs and can aggravate respiratory problems such as bronchitis, emphysema, asthma, and tuberculosis.

VOLATILE MATTER

3. CARBON MONOXIDE, formed by incomplete combustion of carbon, is odorless, colorless, and tasteless. Air containing only one-half of 1% of carbon monoxide would, after sufficient time, cause death.
4. NITROUS OXIDES contribute to smog formation.
5. SULFUR OXIDES. Sulfur combines with oxygen to form sulfur dioxide. It then reacts with moisture and oxygen in the atmosphere to produce an airborne sulfuric acid, which is harmful to humans and vegetation and corrosive to metals and mortar.

Figure 1–5. Potentially dangerous emissions from solid fuels

Most wood smoke problems that occur are not due to the nature of the fuel so much as the manner of the stove's operation. Under conditions of low heat demand, people adjust controlled-combustion woodstoves to restrict the airflow to the firebox and produce a slow-burning, air-starved fire. This practice produces comfortable levels of heat and a long burn, but it also produces volumes of smoke. Much of the heat potential goes up the chimney as smoke, which forms creosote deposits (necessitating costly chimney

cleaning and producing a fire hazard).

Some people are sensitive to the smell of smoke. Others have allergies that are affected by the chemicals in smoke. These can lead to irritable eye, throat, and sinus conditions. Before purchasing a stove, review family medical history related to these problems. An air filter operating in the room with the stove can alleviate most of the smoke fumes.

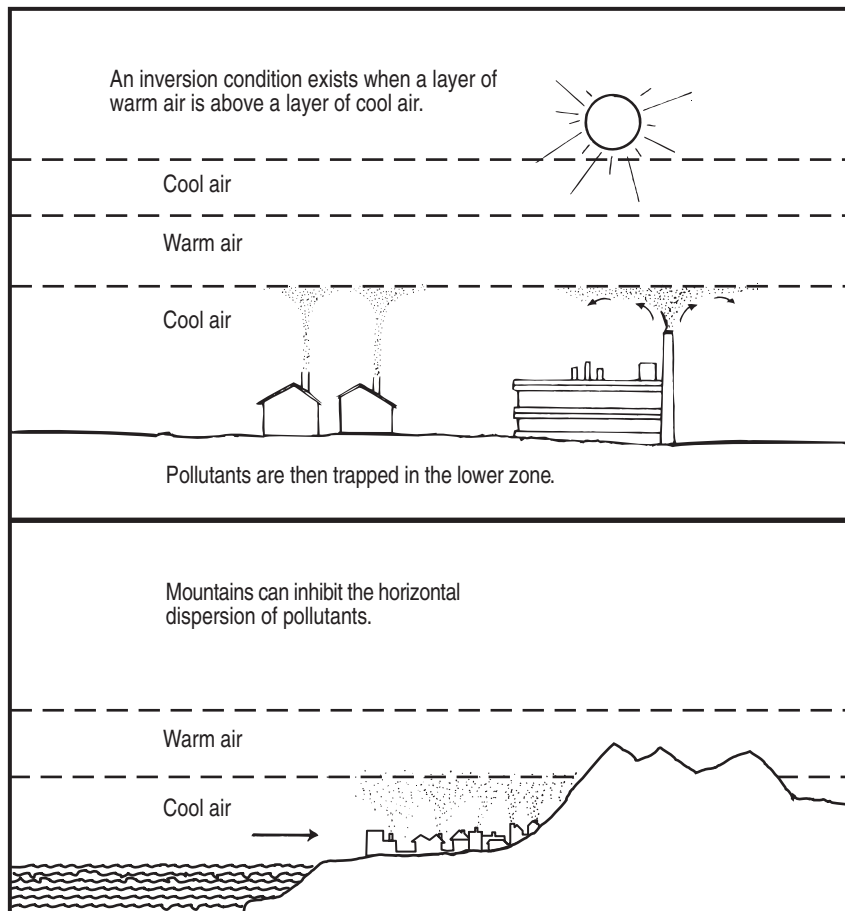

Figure 1–6. Pollution problems can be aggravated by weather and geographic conditions

Chapter 2: Fireplaces

A **masonry fireplace** supplies radiant energy to bring quick comfort to a cold room. However, it is a very inefficient heater. In addition, air that supports combustion in the fireplace is drawn from the room and must be replaced by cold outside air. **The heat radiated to the room may be less than the heat contained in the air that is drawn up the chimney** (figure 2–1). Additional heat can be lost if the flue damper is left open after the fire dies out. Fireplaces should be used to take the chill off the room during mild spring and fall weather.

At the time of construction, a **metal fireplace heat exchanger** can be installed in a masonry fireplace to capture heat by circulating air from the room behind the metal firebox and out into the room, either along the edge or above the fireplace mantle. A fan can be placed in the duct in some of these units. A heat

exchanger can double the heat that reaches the room from a conventional fireplace (figure 2–2, page 14).

Tightly fitting **glass doors** on a fireplace greatly reduce the radiation that reaches the room. However, the doors also reduce the amount of warm air from the room that is lost up the chimney. Probably the most heat will be gained if the doors are opened during the hotter stages of the fire and closed as the fire dies out. The greatest savings occur when the closed doors control the loss of heat overnight.

Factory-built fireplaces are an alternative to masonry fireplaces. They are usually front-loaded and have glass in the door to view the fire. They need to be installed according to the manufacturer’s specifications.

Fireplace designs that feature **heat-storing concrete or stone** (Russian fireplaces) have been tested in independent laboratories at 35–40% overall efficiency and 95% combustion efficiency. This type of fireplace works on the principle of a hot, brisk fire generating high temperatures that warm a large thermal mass. The mass then radiates into the room to provide heat after the fire dies down. The hot fires burn clean, emit very low levels of particulates into the air, and cause little creosote buildup.

Many **fireplace stove inserts** have been developed that fit inside and increase the efficiency of the fireplace. They are available in a wide range of styles for both wood and coal. They may be constructed with heavy plate steel, have firebrick liners, and contain double or triple walls with a fan. Their main advantage is that inserts do not require installing a new chimney or rearranging the living space. Their disadvantage is that there is really no good way to clean the chimney

The heat radiated to the room may be less than the heat contained in the air that is drawn up the chimney.

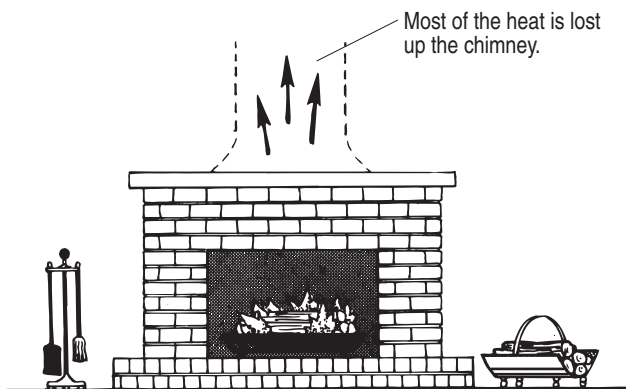

Only 10% of the potential heat available goes to the room.

Figure 2–1. Heat output from a masonry fireplace is usually low

HEAT EXCHANGER

Outlets may be located in an adjacent room or second story.

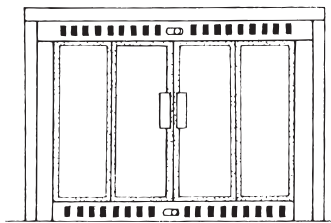
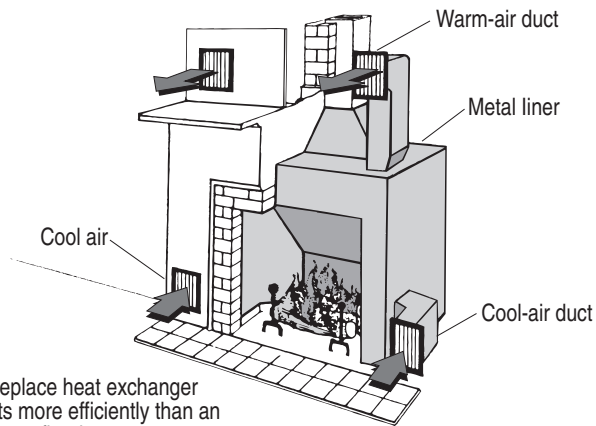

GLASS DOORS

Glass doors reduce the amount of warm air from the room that is lost up the chimney. They also reduce the amount of heat that is radiated to the room.

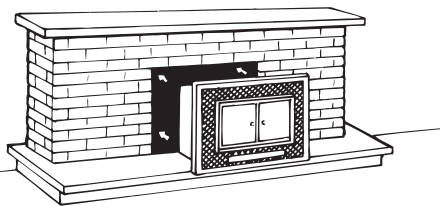

STOVE INSERTS

A fireplace can be converted to an efficient heater with a solid-fuel, controlled-combustion insert.

without removing the heavy insert. Some weigh 400 pounds or more.

Before buying an insert, have the chimney professionally checked to see if the chimney is safe. Carefully measure the fireplace width, height, and depth to be sure the insert will fit. Then follow the manufacturer's instructions for installation. In a typical appliance-to-flue conversion installation, the original damper is removed and replaced with a metal flue plate. A flexible stainless steel connector is inserted up into the first section of the flue liner. A better installation—and one required where the cross-sectional area of the chimney flue is greater than three times the cross-sectional area of the flue collar of the stove—is to use a full-length stainless steel liner. This requirement is expected to be changed to a 2:1 ratio for an exterior chimney. The decision on which system is required is usually left to the local building inspector or fire marshal. Be sure the steel cover panels that close off the space between the insert and the fireplace opening form a good seal. Use fiberglass and high-temperature silicon sealant to seal gaps between bricks or between a large stove and the cover.

A stove may also be set in front of a fireplace and connected to the existing chimney. The same type of stove-to-chimney connections as described above for an insert are acceptable (figure 2-3).

If the stove is too tall for the stovepipe to be inserted directly into the fireplace, the connection can be made above the fireplace. A thimble may have to be installed. This connection may require drilling and cutting the tile flue liner, and that is not easy to do. Hire a qualified mason for this job. Be sure proper clearances to combustibles are kept.

In some instances, creosote may accumulate in the original fireplace shelf area. If ignited, this can create a hot chimney fire. Check frequently for creosote accumulation. Always have a chimney fire extinguisher available.

Figure 2-2. Fireplace options

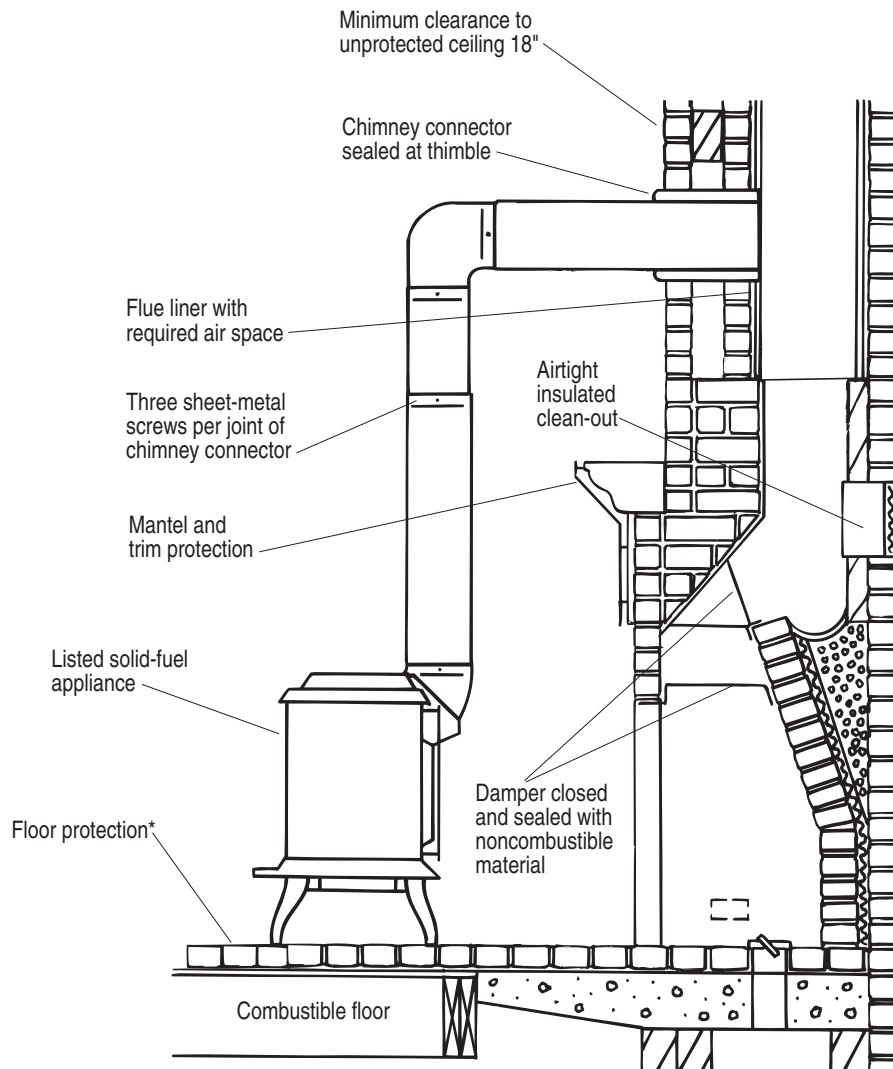

*Floor protection in accordance with solid-fuel appliance listing

Figure 2-3. Installing a stove in front of a fireplace (continued on next page)

Used by permission of the HEARTH Education Foundation.

NOTE: Installation of a fireplace insert or any wood or coal heating unit is best done by a professional with knowledge of and experience with techniques and codes. The National Fireplace Institute® (NFI), a division of the HEARTH Education Foundation (1601 North Kent Street, Suite 1001, Arlington, VA 22209), has developed certification programs for installers and planners of gas, wood, and pellet fireplaces, inserts, and stoves. Search for an NFI-certified specialist in your area and learn more about NFI at < www.nficertified.org >.

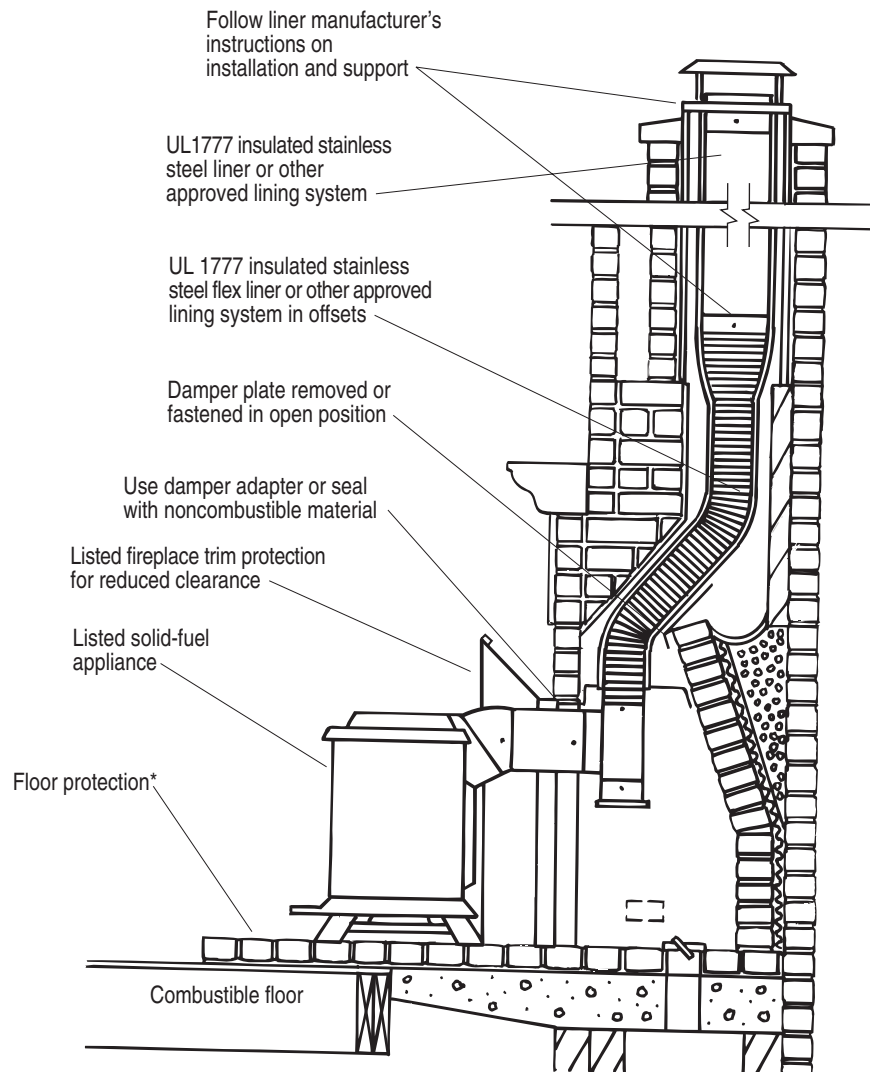

*Floor protection in accordance with solid-fuel appliance listing

Figure 2–3 (continued). Installing a stove in front of a fireplace

Used by permission of the HEARTH Education Foundation.

NOTE: Installation of a fireplace insert or any wood or coal heating unit is best done by a professional with knowledge of and experience with techniques and codes. The National Fireplace Institute® (NFI), a division of the HEARTH Education Foundation (1601 North Kent Street, Suite 1001, Arlington, VA 22209), has developed certification programs for installers and planners of gas, wood, and pellet fireplaces, inserts, and stoves. Search for an NFI-certified specialist in your area and learn more about NFI at < www.nficertified.org >.

Chapter 3: Stoves

There are many manufacturers of wood and coal stoves throughout the world. Size, appearance, style, finish, construction, materials, weight, durability, and ability to burn the fuel efficiently for maximum heat are just some of the characteristics to be evaluated before purchasing a stove.

Stove Size

There is no simple, consistent method to rate stove heating capacity. Various methods include the number of cubic feet the unit will heat, the heat output in British thermal units, or the amount of fuel the stove will hold.

Factors that influence the size of the stove needed are:

- Outside environment—Winter temperature, duration of low temperatures, wind speed and direction
- Construction of home—Ceiling and wall insulation, weathertightness, size and configuration of the rooms to be heated, location of the chimney
- Type of fuel used
- Function—Is the stove the primary heat source, or is it to supplement the existing central heating system?

Oversizing is the most common and serious problem. Not only is there a higher initial cost for a larger stove, but it also will be difficult to burn the fuel efficiently without overheating, particularly during the fall and spring. If the stove is sized for average winter use rather than for the coldest possible conditions, it will be easier to maintain the fire to burn the fuel efficiently. If there is an adequate backup heat source, a moderately undersized stove is better yet. A local, established stove dealer should have the best

experience to help you select the right size stove for the area you want to heat.

Materials of Construction

Plate steel stoves are made from steel $\frac{1}{8}$ inch thick or thicker. These stoves are of welded construction. The firebox is usually lined with firebrick to protect the metal and to provide more even heat.

Cast-iron stoves hold up well under heat, have a long life, spread the heat away from hot spots in the fire, and generally do not warp. Used cast-iron stoves should be thoroughly inspected by persons knowledgeable in their construction to determine if there are any cracked, broken, or missing parts, or areas that are warped or thin.

Soapstone, an attractive, soft stone composed essentially of talc, is used as decoration and the walls for some stoves. Because it has about twice the heat-holding capacity of steel, it provides even heat over a long period. Granite stone may also be used.

Some stoves contain high-temperature **ceramic glass** in the door to be able to view the fire. The design of the stove may provide streams of air that wash over the glass on the inside of the stove to help keep it clean.

Stoves may be finished with a **metallic paint** or a **porcelain enamel**. Trim around doors may be finished with a silver or gold plating.

Stove Types

There are two types of stoves, radiant and circulating, and many styles to fit almost any location and decor (figure 3–1, page 18).

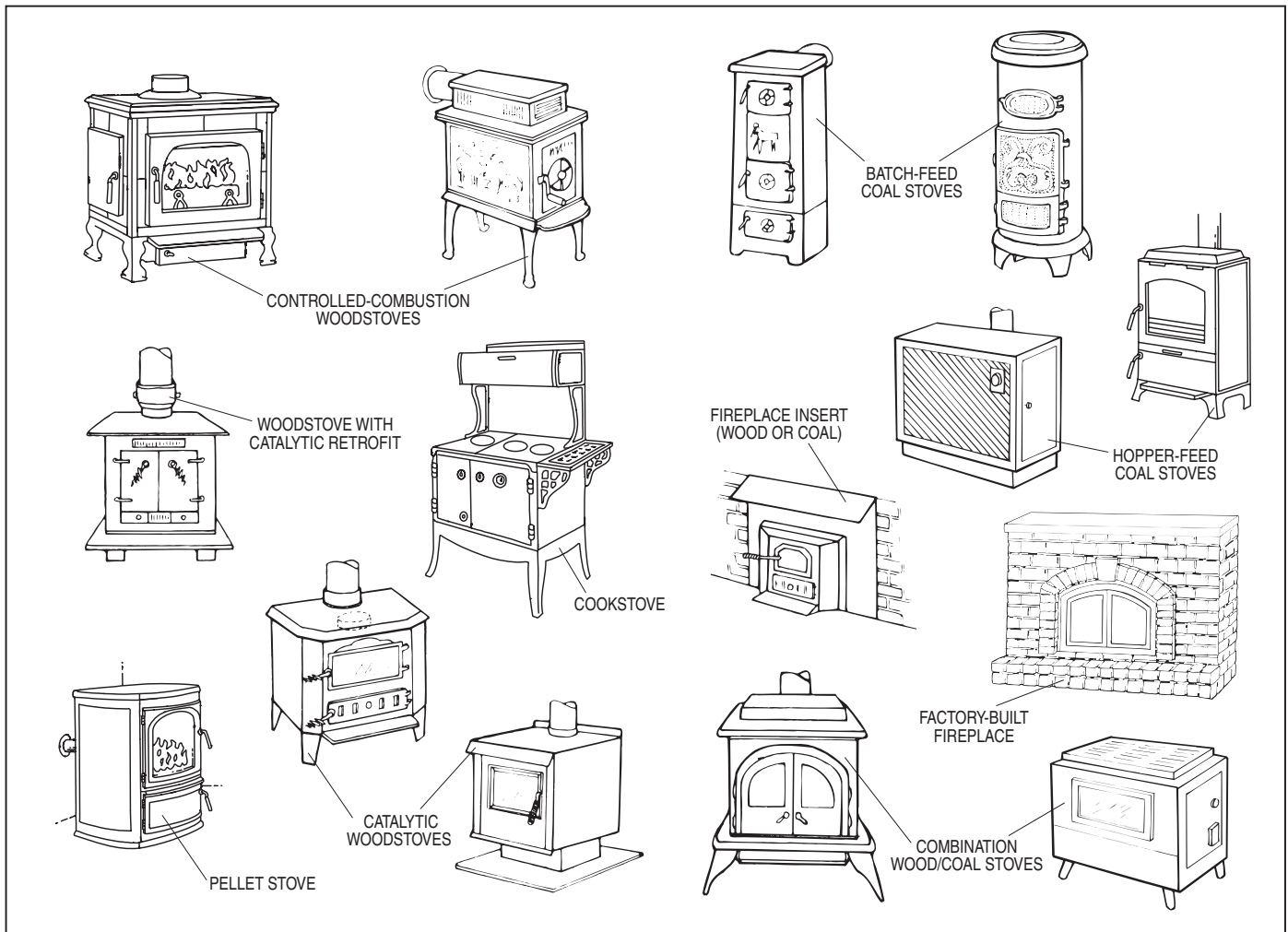

Figure 3-1. Types of stoves

Most wood and coal stoves transfer heat to the room by radiating heat from the hot surface of the stove. **Radiant heaters** produce heat that is most intense at close proximity and diminishes rapidly with distance from the stove. Surfaces in direct line with the stove will be heated. Many people find the comfort of radiant heat hard to beat and enjoy the fact that the family activities tend to center around the fire.

Circulating stoves are constructed with a metal box spaced about 1 inch from the wall of the firebox. Vents in the top and bottom of the outer box allow natural or fan-forced air currents to carry the heat away from

the stove. Circulating stoves can be installed closer to combustible material than radiant stoves, because their outer surface is not as hot. A circulating stove is better suited than a radiant stove to heating a large room.

The **combination stove** can be operated as an open fireplace or a closed stove. Most of these are manufactured of cast iron and are large enough to heat one or two rooms. Some of the stoves are built with tight doors and good draft control. Combination stoves are not manufactured anymore, as they cannot meet U.S. Environmental Protection Agency (EPA) standards.

Some older stoves were described as **dual-fuel** or **solid-fuel stoves**. But because of the differing combustion requirements for coal and wood, you can expect that these units will not burn either fuel as efficiently as a stove designed specifically for one fuel. On the other hand, they do provide the option to switch fuels. On some of these stoves, conversion from one fuel to the other is quite difficult and is generally done only once or twice per season.

Controlled-combustion Stoves

Stoves are often categorized as controlled-combustion stoves to describe appliances that have relatively tight joints and seals so that the rate of combustion can be controlled.

Many older heaters of all types and many Franklin stoves are considered “nonairtight,” as the joints may allow air to enter. Controlled-combustion heaters, available since the early 1970s, are designed with sealed or welded joints. They allow for control of the heat output by careful adjustment of the air inlet controls. Long, even burns are readily obtainable with controlled-combustion heaters, but they should not be operated with a smoldering fire, as high levels of creosote accumulation can occur.

The primary air supply may not be adequate or in the correct position to supply air to support the combustion of the volatile gases, so some stoves have an additional air inlet to introduce secondary air above the flame.

To meet the EPA standards, some manufacturers have added baffles that direct the volatile gases to a hotter area of the fire where they are burned, or to catalytic combustors that reduce the temperature at which the flue gases burn. These features reduce the pollutants and increase the heat recovered from the wood.

Catalytic Woodstoves

An alternative method of burning the volatile gases is

to draw them through a catalytic combustor. Catalytic converters are a standard part of the exhaust system on cars and small trucks. A comparable product has been developed for woodstoves. A precious-metals catalyst makes the flammables in wood smoke burn at lower-than-normal temperatures. The catalyst is a thin coating of platinum or palladium applied to a honeycomb disc.

Several companies manufacture catalytic-combustion stoves, as well as add-on combustors for existing controlled-combustion stoves (figure 3–2). Catalytic

CATALYTIC ADD-ONS

Catalytic add-ons are often mounted on the stovepipe close to the stove.

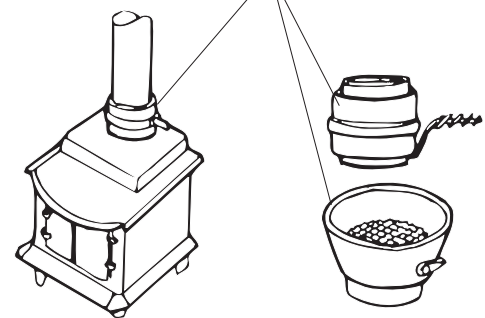

CATALYTIC STOVES and FIREPLACE INSERTS

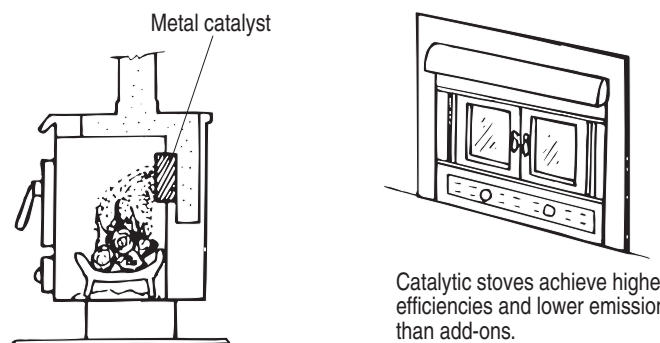

Precious-metal catalysts make the flammables in wood smoke burn at lower-than-normal temperatures.

Catalytic stoves achieve higher efficiencies and lower emissions than add-ons.

Figure 3–2. Catalytic woodstoves and add-ons

systems have the potential for clean burns when the stove is filled to capacity, dampered down, and left for eight to ten hours until the next refueling.

The catalyst effectively reduces the normal temperature at which the flammable gases burn from 1,200°F or above to as low as 450°F. Once the reaction begins, the temperature in the catalytic unit soars. Wood smoke is reduced, so almost no creosote or air pollution is created, and overall energy efficiencies are dramatically increased. Some testing labs have shown a 25–30% increase in efficiency for catalytic-combustion stoves over older-model stoves.

All catalytic combustors must be replaced, usually every few years. They can be damaged when anything other than wood or newspaper is burned in the stove. Wrapping paper, painted wood, artificial logs, lighter fluids, and chemical chimney cleaners are **not** to be used.

Pellet-burning Stoves

Another type of stove designed to consume its own smoke burns dry, pelletized wood, so air pollution is virtually eliminated. Unlike woodstoves, pellet stoves have a hopper to hold the fuel. Some will hold up to 50 pounds, enough for more than 24 hours of operation. Pellets are fed to the stove's firepot by gravity or a motorized auger. A blower or fan supplies air to the fire to obtain a clean burn. Ash has to be removed less frequently, as the fuel is cleaner and burns more completely than chunk wood.

Heat output is controlled by an electronic panel that regulates the flow of pellets into the firepot. The panel may also regulate the air supply to the fire and the blower that circulates room air past the heat exchanger. Some stoves operate with a thermostat similar to the one on a central heating furnace. The exhaust from the firepot is vented outdoors through a 3-inch-diameter chimney or vent pipe. In most models, air for combustion is drawn from outside

and doesn't create cold floor drafts as other types of stoves commonly do.

Pellet stoves require electricity to operate the fan and auger motors. Some models have a battery-operated backup should the power be interrupted; otherwise a backup generator is a good investment. Although a pellet stove costs more than a woodstove, installation costs are lower.

Pellet stoves and fireplace inserts are found in several outputs. Pellet furnaces and boilers, designed for whole-house heating, are also available. When purchasing a pellet stove, look for a model that will burn a variety of pellet materials, as manufacturers mix fuels depending on availability and price. As the electronics on most stoves is warranted for only one to two years, you may want to opt for a service contract.

Coal Stove Design

Coal stove design must meet important requirements for ignition and combustion, and each coal stove is designed to burn a particular type of coal. Coal requires large amounts of sustained heat for ignition and continued combustion. A **deep firebox** is necessary to encourage "back radiation" through the coals to sustain these high temperatures.

Cast iron, firebrick, or fireclay protect the metal firebox, retain heat, and help to maintain a uniform heat output. Firebrick held in place with metal brackets or cemented in place is preferred to a liner cast in the shape of the firebox, as any liner or firebrick will deteriorate eventually and require replacement.

The combustion air must be able to pass up completely through the bed of burning coals. The coal is supported on a **cast-iron grate** to permit even air distribution and allow for ash removal without disturbing the fire.

Two basic types of coal stove designs are the **batch-feed stove** and the **hopper-feed stove** (figure 3–3). In the batch-feed stove, a charge is placed in the firebox, is heated, and burns down. In the hopper-feed stove, coal feeds slowly and continuously from the hopper until it is empty. The batch-feed stove design is simpler and its price generally lower than the hopper-feed stoves. Batch-feed stoves are generally loaded from the top or side of the stove and require more care when loading to ensure that the fire is not smothered.

Hopper-feed stoves are loaded from the top into an inner hopper which feeds the coal by gravity into the fire chamber. The burning rate is controlled more exactly, since the depth of the burning coal remains relatively

constant regardless of how hot the fire is burning. The coal in the hopper does not ignite, because it is sealed at the top to exclude combustion air, and no heat or flue gases pass near it. A longer flame path for the flue gases gives higher heat transfer efficiency.

Ash-removal systems that include shaker grates or slicers are necessary to remove the ashes. Coal produces seven to ten times as much ash as an equivalent amount of wood, making ash removal a daily fire-tending chore. Approximately 1 gallon of ash is produced for every 40–50 pounds of coal burned. If you choose a stove with a large, well-designed **ash pan**, ash removal can be done less frequently.

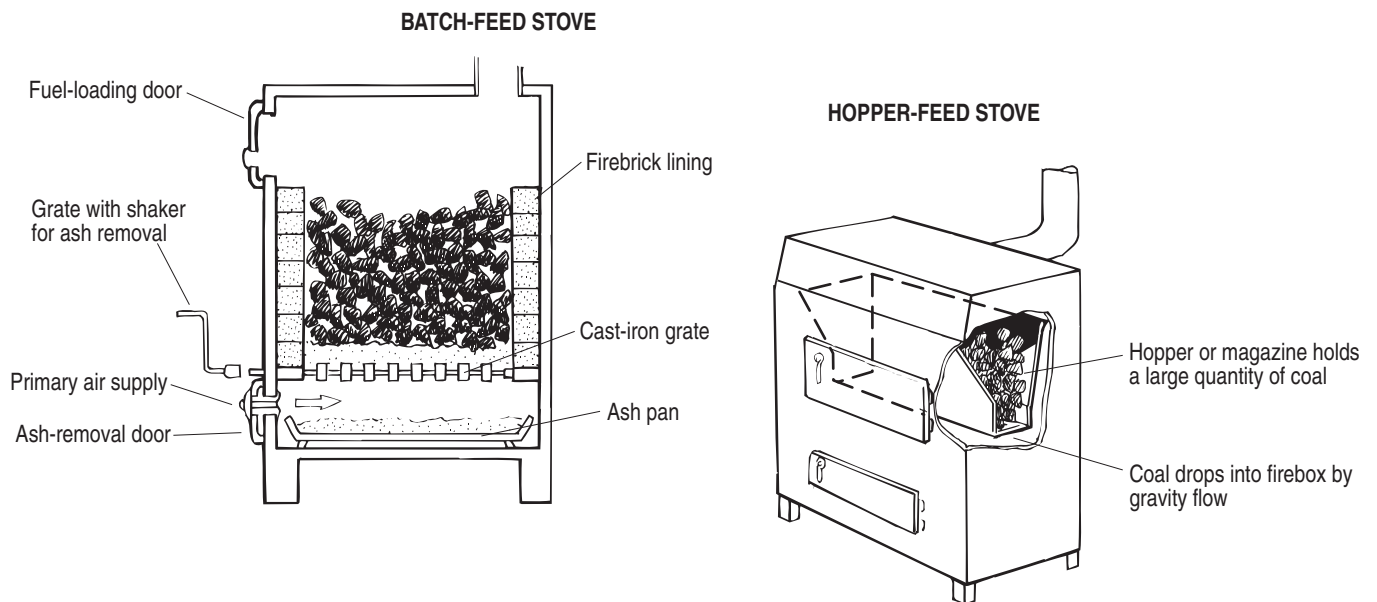

Figure 3–3. Two basic types of coal stove designs: batch-feed and hopper-feed

BLANK

Chapter 4: Furnaces and Boilers

A central heating system, although more expensive, has several advantages over a stove. Located in the basement, it provides longer, more efficient burn cycles and more uniform temperatures throughout the house. It also keeps the ash and dust out of the living area. Automatic controls make a central heating system safer to operate.

Furnaces are available that heat air and distribute it through a duct system. Boilers heat water and distribute the heat through radiators. Units are available that are stand-alone or attached to the present heating system (figure 4-1).

Central Heating Options

An **add-on furnace or boiler** is attached to and supplements an existing heating system. This type of unit costs less than a complete system, because the existing heat distribution system is used. But add-on systems require additional space for the new unit, including clearance from combustible materials, space for loading and servicing, and a separate flue in the chimney. A larger or additional expansion tank and a heat-dump zone may be necessary when an add-on boiler is installed. The heat-dump zone is a zone of radiators in the home in which hot water from the coal or wood boiler can be circulated should the boiler overheat.

ADD-ON UNITS

Additional protection may be required around pipes or ducts due to higher temperatures.

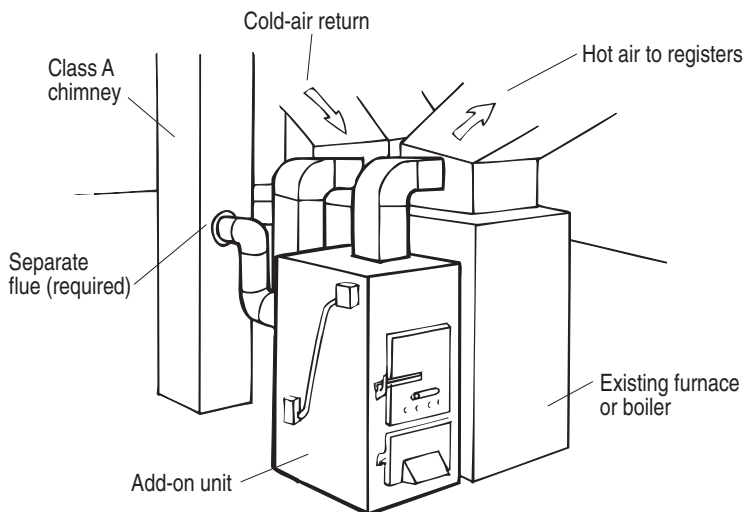

Additional space is required for the add-on unit and for servicing and loading. Add-on units are usually less efficient than independent units.

MULTIFUEL UNITS

Multifuel systems cost more than conventional systems but allow for a choice between fuels based on expense, convenience, or fuel availability.

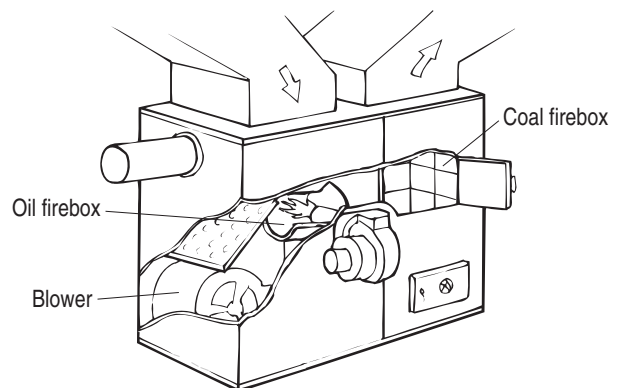

Fireboxes designed for each type of fuel are usually more efficient than a single firebox.

Figure 4-1. Solid-fuel central heating

The **multifuel furnace** or boiler can be a good choice in new homes or as a replacement to an old heating system. These units burn wood and/or coal in combination with oil, gas, or electricity. Multifuel systems are generally more expensive than conventional furnaces, but they allow a choice between fuels based on expense, convenience, or availability. And by automatically switching to the alternate fuel, they keep the house warm when no one is home to keep the fire burning.

Multifuel units are similar to other solid-fuel units in operation and controls, except for the design of the firebox. Some have separate fireboxes for each fuel burned; others use only one. A firebox designed for each type of fuel is usually more efficient than a single unit. A firebox designed to burn wood efficiently may be too large for burning oil. Fouling of the gas or oil burner from soot or creosote formation is one of the problems that can occur in the dual design.

Advantages to the multifuel furnace or boiler as compared to an add-on unit are that less space is needed, only one chimney is required, and installation is simpler.

Wood-chip and pellet furnaces, stoked from a hopper or by a small auger, are very efficient, and the firing rate can be controlled to match the heating load. Wood-chip furnaces are generally restricted to commercial applications, as chips are not readily available in most areas, and they must be stored under cover.

Outdoor wood-fired boilers keep the dirt and ash outside the home. The unit is usually located within 200 feet of the house, where fuel can be easily supplied and where the heat can be piped to the home (figure 4–2).

An outdoor wood boiler usually consists of a large firebox surrounded by a water jacket. Large fuel doors

allow big pieces of wood to be used, which reduces the amount of splitting needed. It also can extend the burn time to more than 24 hours between recharging.

The heated water (about 185°F) from the boiler is pumped to the dwelling through insulated pipes buried about 12 inches below ground, and heat is distributed in the home by wall or floor radiators or a water-to-hot-air heat exchanger. A thermostat on the water jacket activates the draft or combustion blower to increase the intensity of the fire when the water temperature starts to fall. When heat is needed in the home, a thermostat located in the living area activates a circulating pump that moves hot water through the radiators.

Tests conducted by the U.S. Environmental Protection Agency (EPA) to determine emissions from the chimney found that outdoor wood-fired units are similar to other wood-burning appliances. But operation is generally a large factor in how much

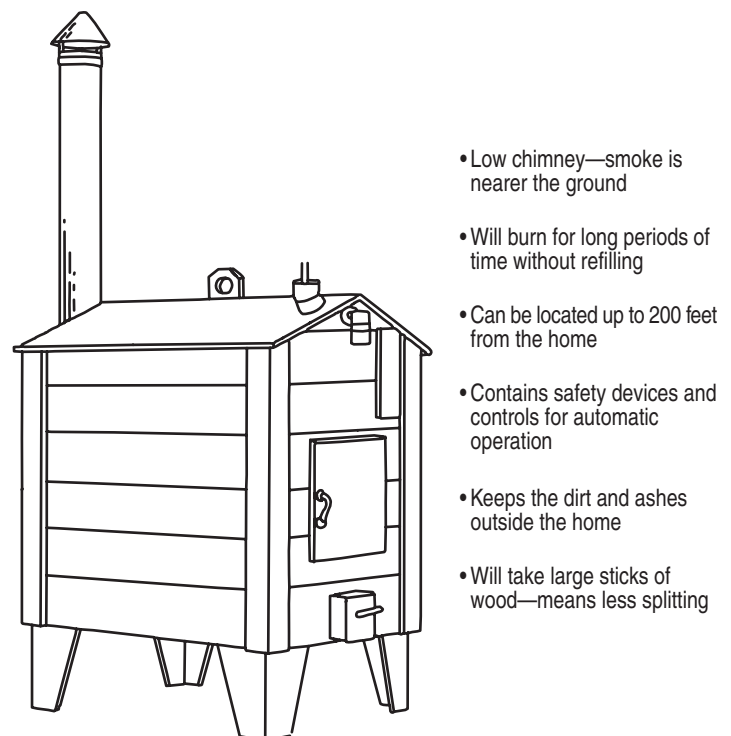

Figure 4–2. Outdoor wood-fired boiler

smoke is generated. Units that are too large for the home or units that cycle infrequently build up a layer of creosote that burns off when the fire is rekindled. Also, as the most complete combustion takes place at fire temperatures above 1,000°F, large steel surfaces backed by 150°F water tend to chill the gases and form smoke. Because of this, delivered efficiency may be in the 50% level, whereas most of the EPA-certified stoves operate with an efficiency of 60–80%. This means that more wood is needed.

Here are a few more things to consider before purchasing an outdoor boiler:

- The fire will burn hotter and create less smoke if the firebox is lined with firebrick.
- The boiler should have a well-insulated jacket, preferably with fiberglass insulation.
- Insulated or cast-iron doors will not warp and will therefore provide a tighter seal and better control.
- A forced draft maintains a hotter, more efficient fire and decreases creosote and ashes. This reduces the need for a water jacket with a large capacity, as temperature recovery time is reduced.
- A pressurized, closed-loop distribution system with rust inhibitor added to the water and a piping system with an oxygen barrier will reduce rust formation.
- The economics of installing a system needs to be studied, as residential systems cost \$4,000–\$12,000. Payback may be long if the wood has to be purchased.

Features

Most furnaces and boilers require less stoking than stoves because of the large fuel capacity and controlled burning. Some of these units have a storage hopper, which holds a large charge of wood and feeds it slowly into the combustion zone. Others have extremely large fireboxes that permit the stoking of quantities of large chunks of wood—as large as 13 inches in diameter and 5 feet long. Though burning large chunks is not

as efficient as burning small sticks, there are savings in fuel preparation costs.

Most furnaces and boilers are thermostatically controlled. When the thermostat is not calling for heat, the primary air supply is very low, and the fire continues with a very low heat output. When heat is demanded by the thermostat, the primary and secondary air supplies are activated, and the fire then burns at a high rate with near complete combustion.

In addition to stoking the fire, solid-fuel furnaces require more maintenance than gas- or oil-burning furnaces. Ash removal and periodic chimney cleaning are required. The boiler or heat exchanger may need cleaning to remove deposits. Boilers may require the homeowner to understand the distribution system and controls. Before purchasing a solid-fuel furnace, talk to someone who already has one to learn more about their pros and cons (see figure 4–3).

Consider the following features when selecting a furnace or boiler:

- Choose a unit approved and listed by a nationally recognized testing agency, i.e., Underwriters

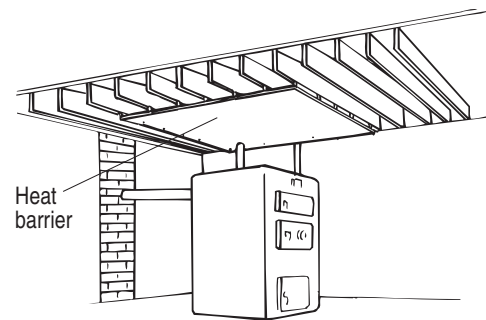

Installation of a heat barrier above the furnace or boiler may be necessary; separate the barrier from joists with noncombustible spacers.

Central heating systems keep the fuel and equipment out of the living area, but you also lose the efficiency and comfort of a radiant heat source in the most used living area.

Boilers may require the homeowner to understand the distribution system and controls.

Figure 4–3. Pros and cons of a central heating system

Laboratories Inc., Energy Testing Laboratory of Maine, or others. Many states require that only approved units be installed. Check with the local building inspector or fire marshal before purchasing a unit, since installations of all heating systems require a permit.

- Steel is the most common material used for fireboxes. Some fireboxes use firebrick or cast-iron liners to increase the life of the steel and increase the temperature maintained. A few fireboxes are made of stainless steel for longer life.
- Choose a unit that has both primary and secondary air supplies. Many new designs have electronic controls that regulate the rate

of firing, draft inducers that provide the right amount of air, heat storage that absorbs extra heat, and heat reclaimers to capture the heat of combustion before it escapes up the chimney.

- Check whether the unit can be operated during a power failure. Most solid-fuel furnaces, like conventional furnaces, depend on electricity to operate thermostats, controls, and pumps or fans to distribute heat. The units that can be operated during a power failure usually utilize the thermosiphon or gravity principle.
- Domestic hot-water coils are available for many heaters and boilers. Of course, to provide hot water year around, the unit must be fired in summer as well as in winter.

Chapter 5: Installation

An improperly installed solid-fuel heating unit can cause a fire. A permit and inspection are required for all heating-system installations, including fireplace inserts. Before you buy and install a stove, check with your local building inspector. If you live in a rural area that does not have a building inspector, check with the local fire marshal.

Home insurance should also be considered when installing a stove. Currently, there is no uniform national policy for insurance firms regarding stove installations. All insurance companies stress the importance of safe installations, even though they do not inspect heating systems on their own. That job is usually left to the local building inspector.

Ordinarily, there are no changes in insurance policy premiums due to the addition of a properly installed stove, although some companies impose a surcharge. However, if the appliance is improperly installed, it may be considered an unreasonable added risk, and the insurance policy could be canceled. Because of potential conflict with an insurance company policy, it is advisable to notify your insurance agent before you purchase or install a stove.

Stove Testing and Certification

Starting in 1988, woodstoves—except pellet stoves, antique stoves, cookstoves, and wood-fired central heating furnaces—have to be tested and certified to meet U.S. Environmental Protection Agency (EPA) standards for air pollution emissions. These standards limit the emission of particulate matter to 4.1 grams per hour for appliances with a catalytic combustor and 7.5 grams per hour for appliances without a catalytic combustor. Stoves that meet these standards use less wood and reduce the need for chimney cleaning. They also lower the amount of particulate matter that gets

into the atmosphere. Stoves that were manufactured before July 1, 1988, are not required to meet these standards and can still be installed in most states.

All new stoves, factory-built fireplaces, and furnaces are tested, listed, and labeled to Underwriters Laboratories, Inc. (UL) standards for safety and installation by one of a number of recognized testing laboratories. The installation procedure and wall and floor clearances are particular to each model of stove and are included in the operator's manual that comes with the stove. These should be followed when installing the stove.

Stove Clearances

As this book is being revised, the new International Mechanical Code is being adopted across the United States to replace regional codes, such as BOCA, UBC, and SBC.

If you have an older stove that does not have a UL listing, the National Fire Protection Association (NFPA) standard NFPA-211 generally applies and is the basis of many local codes. These govern the distance that the stove and stovepipe must be located from combustibles. They also recommend alternate materials and procedures that allow the distance to be reduced (figure 5-1, page 28).

Floor Protection

Protect combustible floors from radiant stove heat, flying sparks, and hot ashes by extending the material used to protect the floor. Noncombustible materials commonly used to improve the appearance of the installation, such as stone, tile, brick, or marble chips, can be placed over the basic NFPA-recommended materials (table 5-1, page 29).

Wall Protection

If your stove does not have a UL listing, or if you don't have an instruction manual, the NFPA or International Mechanical Code standards generally apply. Locate a stove or heater at least 36 inches from unprotected woodwork, other combustible materials, or furniture.

Maintaining minimum clearance is critical, because wood that is continually reheated will ignite at a much lower temperature than fresh wood. A new wall will start to burn at between 500°F and 700°F. If this wall is continually heated and dried out over time, the ignition temperature can drop to 250°F. For this reason, an improper installation becomes a time bomb.

Many noncombustible or fire-resistant materials, such as plaster, cement-fiber board, gypsum board, and brick, are good conductors of heat. This means that the

The National Fire Protection Association (NFPA) or International Mechanical Code standards for clearances from combustibles, as outlined in this chapter, can be used if your stove is unlisted or does not have an operator's manual outlining installation procedures.

side touching the studs may be just as hot as the side exposed to the heat. Any combustible touching one of these materials can char and eventually catch fire.

The 36-inch clearance between the stove and combustibles can be reduced considerably if the walls and ceilings are protected with mineral fiber, masonry, or 24-gauge sheet metal spaced out 1 inch from the combustible wall. The space allows air to circulate behind the panel to cool the wall. The spacers must be made of noncombustible material, such as a stack of washers, small-diameter pipe, electrical conduit, or tubing. The appearance of the approved materials may be improved with fire-resistant paint or a facing of tile or Z-brick attached with high-temperature adhesive (see table 5-2; table 5-3, page 30; and figure 5-2, page 31).

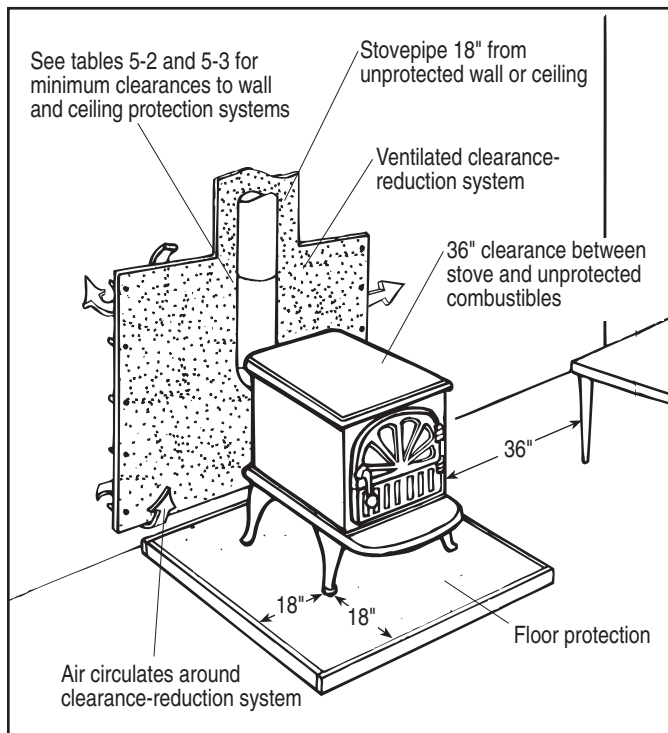

Figure 5-1. Minimum clearances from combustibles for unlisted stoves

Furnace Duct Clearances

Hot-air furnace ducts require the following clearance from combustibles—18 inches for the first 3 feet from the furnace plenum, 6 inches for the next 3 feet, and 1 inch when more than 6 feet from the plenum (figure 5-3, page 31).

Keep hot water or steam pipes 1 inch from combustibles. The clearance may be reduced to $\frac{1}{2}$ inch where a pipe passes through a floor, wall, or ceiling.

Stovepipe

The chimney connector or stovepipe used to connect the outlet of the firebox to the chimney is sold in various lengths. Building codes require it to be 24-gauge or thicker; lower gauge numbers indicate

Table 5–1. Recommendations for floor protection under an unlisted stove*

TYPE OF UNIT	PROTECTIVE MATERIAL
Stove has less than 2 inches of open space beneath the fire chamber or base.	May not be placed on floors of combustible construction.
Stove has 2–6 inches of open space beneath the fire chamber and base.	Protect combustible floors with 4-inch hollow masonry block, laid with ends unsealed and joints matched to allow air circulation. The masonry must extend 18 inches on all sides of the unit and be covered with 24-gauge sheet metal.
Stove has legs that provide over 6 inches of open space beneath the fire chamber or base.	Protect combustible floors with 2-inch-thick closely spaced brick, concrete, or stone. The masonry must extend 18 inches on all sides of the appliance and be covered by 24-gauge sheet metal.

* Adapted from NFPA–211

Table 5–2. Minimum installation clearances from combustible walls and ceilings for unlisted solid-fuel heaters and furnaces*

TYPE OF PROTECTION	AS WALL PROTECTION	AS CEILING PROTECTION
None	36 inches	36 inches
3/2-inch-thick masonry (brick) wall without ventilated air space	24 inches	Does not apply
1/2-inch-thick noncombustible insulation board over 1-inch fiberglass or mineral wool batts, against the combustible assembly without an airspace	18 inches	24 inches
24-gauge galvanized sheet metal with or without insulated backing, 1 inch off the combustible assembly	12 inches	18 inches
3/2-inch-thick masonry (brick) wall with ventilated air space	12 inches	Does not apply
Two layers of 24-gauge galvanized sheet metal having 1-inch air space or 1-inch fiberglass insulation between layers, spaced 1 inch off the combustible assembly	12 inches	18 inches

* Adapted from the 2000 International Mechanical Code

Table 5–3. Minimum installation clearances from combustible walls and ceilings for stovepipes*

TYPE OF PROTECTION	STOVEPIPE CLEARANCE FROM CEILING	STOVEPIPE CLEARANCE FROM WALL
None	18 inches	18 inches
24-gauge galvanized sheet metal with or without 1-inch fiberglass insulation backing, spaced 1 inch off the combustible assembly	9 inches	6 inches
Two layers of 24-gauge galvanized sheet metal with 1 inch air space or 1 inch fiberglass insulation between, spaced 1 inch off combustible assembly	9 inches	6 inches
½-inch inorganic insulating board, over 1-inch fiberglass or mineral wool batt, against the combustible assembly	12 inches	9 inches
3½-inch brick wall, spaced 1 inch off the combustible assembly	Does not apply	6 inches
3½-inch brick wall, against the combustible assembly	Does not apply	12 inches

*Adapted from 2000 International Mechanical Code

Notes:

1. Spacers and ties shall be noncombustible.
2. A chimney connector (stovepipe) shall not pass through any floor or ceiling unless the connector is labeled for such. If a single wall connector passes through a masonry wall, maintain ½ inch open ventilated air space between the connector and the masonry.
3. Required air space for clearance protection shall be open around the edges to allow air circulation.

thicker metal. The diameter of the connector should be the same diameter as the firebox outlet. Most woodstoves use either a 6-inch or 8-inch connector; a smaller diameter than the firebox outlet will possibly cause improper draft.

Some stove installations require a damper in the pipe near the stove to control draft and loss of volatile gases. Check the recommendation of the stove manufacturer. Add-on catalytic converters can be inserted into stovepipes to increase the efficiency of and reduce emissions from older stoves without controlled combustion.

Stovepipes should be short and straight and enter the chimney higher than the outlet of the stove’s firebox. A rule of thumb is to keep the connector less than 10 feet long to avoid excess heat loss from the flue gases and reduce creosote accumulation.

Avoid horizontal runs. Instead, use 45-degree angles to create an upward slope in the connector. Try to have no more than one right-angle turn between the stove and chimney.

Stovepipe connections should be tight and held together with three sheet-metal screws at each joint.

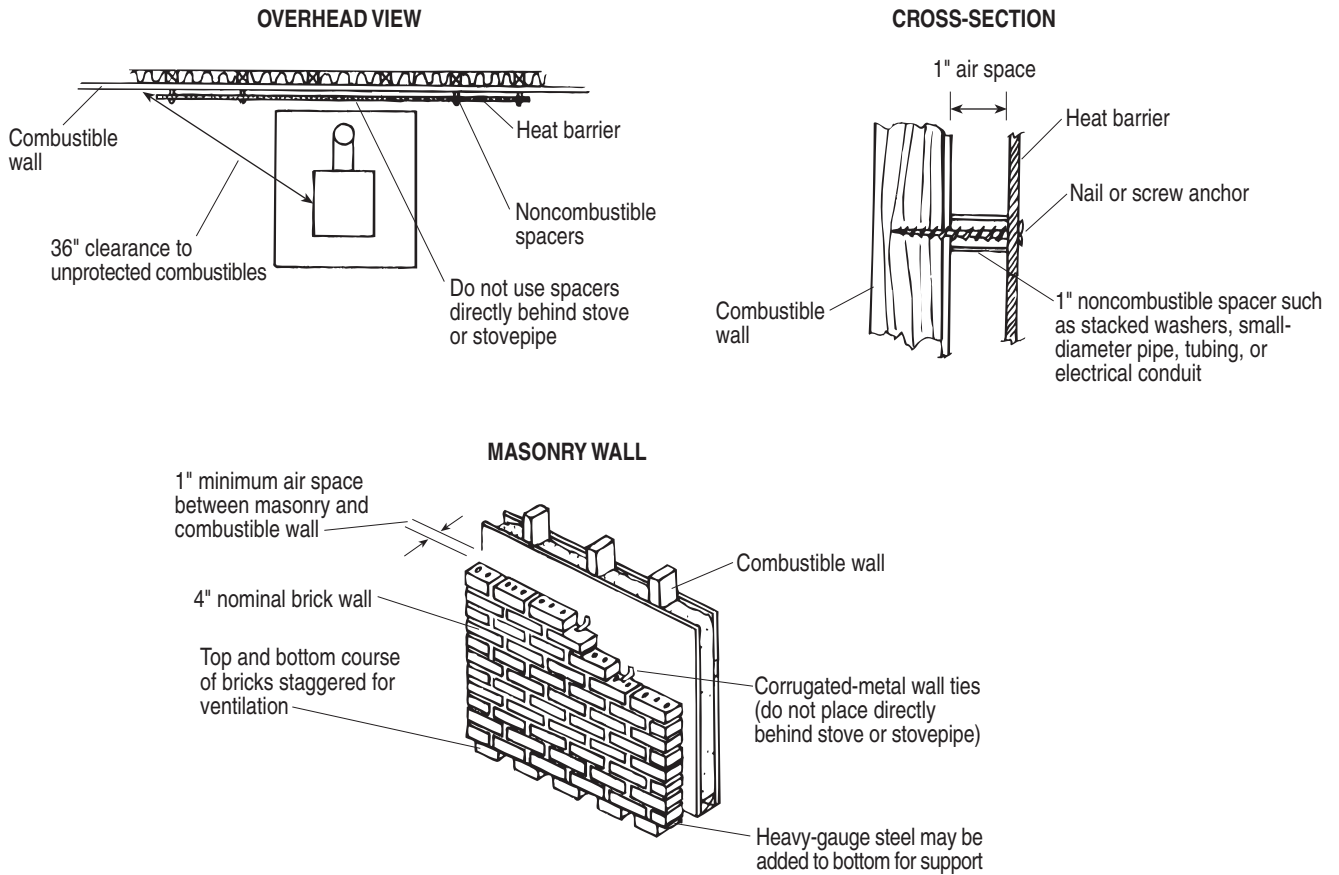

Figure 5-2. Provide air circulation around heat barriers

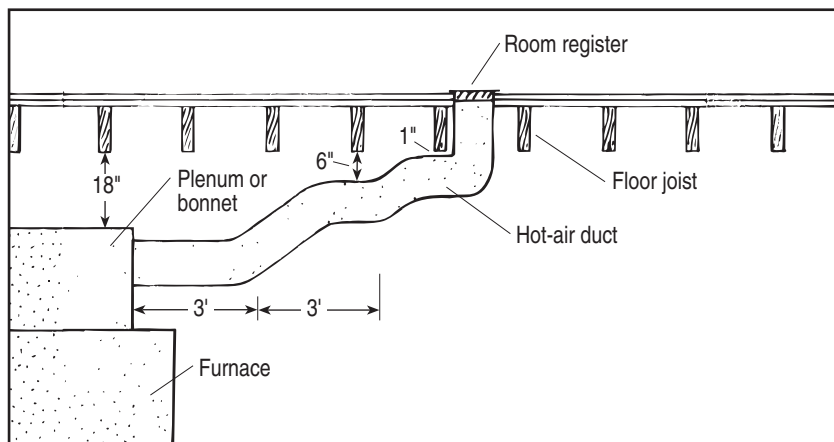

Figure 5-3. Furnace duct clearances

Forced-draft systems and all portions of induced-draft systems under positive pressure should be installed so as to be gas-tight to prevent leakage of combustion products into the house.

Unlisted Stove Installation Checklist

Refer to the stove manufacturer's installation manual for procedure and instruction details. If you have purchased a used stove, try to obtain a copy of the installation manual. If you do not have the stove manufacturer's installation instructions, use this checklist **before** starting the first fire to improve the safety of the installation. This checklist also applies to stoves without instructions or labels.

- A stove installation permit has been obtained from the building inspector or fire marshal.
- The stove has no broken or missing parts or cracks that make it unsafe to operate.
- The stove is located on a noncombustible floor, or an approved floor protection material is placed under the stove. Floor protection extends out 18 inches on all sides of the stove.
- The stove is spaced at least 36 inches away from combustible material (walls, furniture, draperies, wood box, etc.), or if it is listed, it is installed in accordance with the conditions of the listing or label. For reduced clearance, fire-resistant materials such as brick, inorganic insulation board, or galvanized sheet metal are installed in compliance with the building code.
- The chimney connector (stovepipe) of 22- or 24-gauge metal is sealed and secured with three sheet-metal screws per joint and properly supported.
- The chimney connector diameter is not reduced between the stove and the chimney.
- The total length of the chimney connector is less than 10 feet.
- There is at least 18 inches between the top of a horizontal chimney connector and the ceiling or other combustible material.
- The chimney connector slopes upward at least $\frac{1}{4}$ -inch rise per foot of length toward the chimney and enters the chimney horizontally through a thimble that is higher than the outlet of the stove firebox.
- The chimney connector does not extend into the chimney flue lining.
- A noncombustible seal is used where the connector enters the thimble.
- The chimney connector does not pass through a floor, closet, or concealed space, nor does it enter the chimney in the attic.
- A safe-clean masonry chimney that does not serve another heating appliance is used. All previous breaches (flue connections) have been properly sealed. As an alternative to a masonry chimney, a UL-approved ALL FUEL OR HIGH-TEMPERATURE (HT) factory-built chimney is installed in accordance with the manufacturer's instructions.
- The chimney flue lining is not blocked.
- The chimney flue lining and the connector are clean and in good condition.
- A stove shovel, poker, heat-resistant gloves, and metal container with tight-fitting lid are available for ash disposal.
- The building official or fire marshal has approved the installation.
- The company insuring the building has been notified of the installation.
- In addition to smoke detectors located in the hallway outside sleeping areas, a smoke detector is installed on or near the ceiling in an area adjacent to the stove.
- A fire extinguisher (with at least 1A:10B:C rating) is near the entrance to the room with the stove.

Chapter 6: Chimneys

The chimney has two main purposes—to create a draft and to vent the gases of combustion. It also discharges some of the heat generated by the fire.

The draft works on the principle that a column of hot air or gas is lighter than a column of cooler air. As the flue gases are heated, they rise in the flue and are replaced by air drawn in through the openings in the stove.

A strong draft is particularly important for coal burning to draw air through the deep, tightly packed coal bed (particularly with the smaller sizes of coal). Do not install a stove in a chimney with a history of backdrafting or flow reversal, since the stove will not operate well, and carbon monoxide and other pollutants may enter the house. Consult a certified hearth specialist or chimney professional for help in diagnosing possible causes and remedies.

Factors Affecting the Draft

- Increasing the height of the chimney increases the draft. For this reason, basement heating units often burn better than those located in the upper stories.
- The higher the flue gas temperature, the greater the draft. For most chimneys, if the average temperature of the flue gases is kept 200°F above the outdoor temperature, there should be adequate draft to burn coal. Interior chimneys or insulated chimneys (either metal or masonry) help keep flue gas temperatures high enough to ensure good draft.
- If the chimney is too large for the size of the stove, the flue gases will be cooled, and the draft may not be adequate to keep the fire going. In this case, a reliner, usually a stainless steel pipe of 6 to 8 inches in diameter, may be

inserted the length of the chimney and 4 inches beyond the top of the chimney. A fabricated cap covers the chimney top between the pipe and the flue.

- A sooty or dirty chimney will restrict the draft. Periodic cleaning is necessary.
- Well-sealed stovepipe connections and an air-tight stove help achieve a better draft.

If the draft is insufficient, purchasing a unit with a forced draft, usually a small blower, can solve the problem. The joints on the positive-pressure side of the blower should be sealed to prevent flue gas leakage into the house.

Chimney Types

Factory-built Chimneys

Factory-built chimneys are easier to erect than masonry ones (figure 6–1, page 34). Tests at the National Bureau of Standards have shown that metal and masonry chimneys differ little with respect to draft when used under similar conditions. Factory-built chimneys used with solid-fuel-burning appliances must be UL listed as HIGH TEMPERATURE (HT) chimneys. An exception to this is for some factory-built fireplaces and fireplace stoves. Follow the manufacturer's requirements for these. Do not use the UL-listed “vent” chimney, as it is not insulated or ventilated enough for wood or coal burning. A vent for a pellet-burning stove should be listed and labeled for such use.

There are two types of metal chimneys, an insulated chimney and a triple-wall chimney. Insulated factory-built chimneys are made of a stainless steel outer casing, 1 inch of insulation, and a stainless steel inner liner.

Triple-wall chimneys are constructed either with dead

INTERIOR INSTALLATION (Preferred)

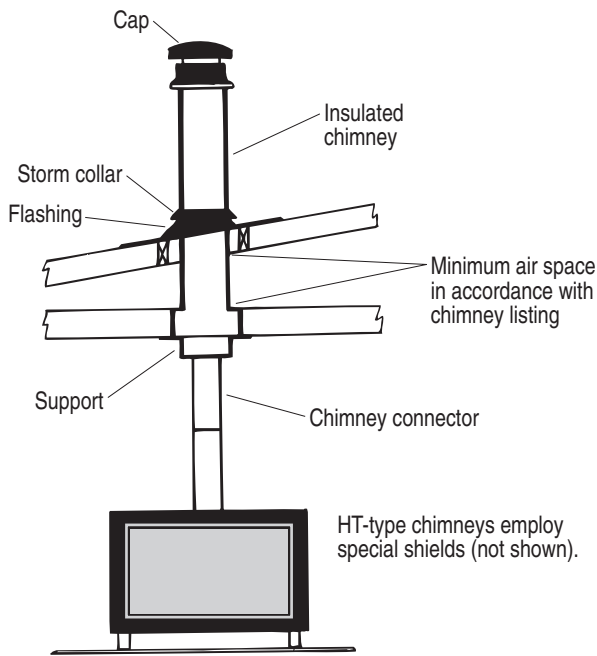

OUTSIDE INSTALLATION

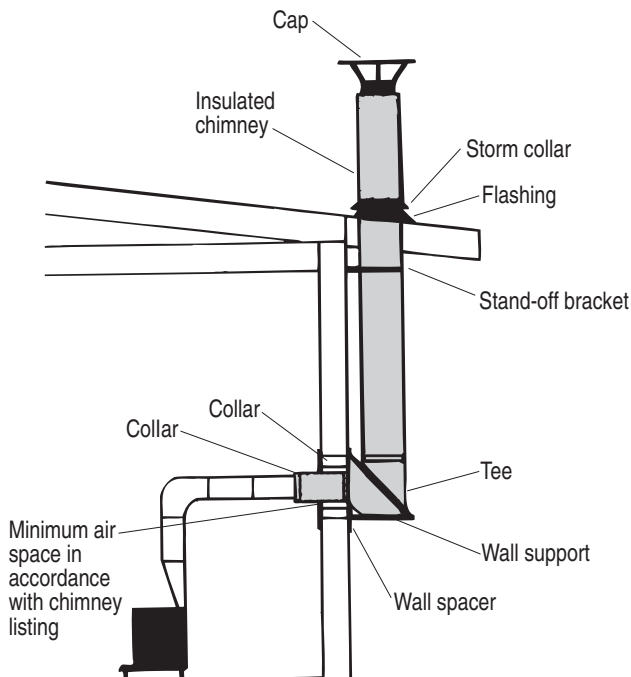

Figure 6–1. Factory-built chimneys

air spaces between sections or such that outside air passes down between their outer walls and up along their interior walls. This movement of air cools the chimney and may add to creosote formation.

Masonry Chimneys

The material cost for masonry block chimneys is less per foot of length than factory-built chimneys, but much more labor is required for construction. A masonry chimney acts as a large heat sink to radiate warmth into the room after the stove cools—if it is inside the house and not on an outside wall.

Existing chimneys that are unlined or in need of repair should not be used. They should be rebuilt or sometimes can be insulated and restored to function safely for solid-fuel appliances. One such restoration scheme uses a lightweight, acid-resistant cement and volcanic ash compound which is inserted around an inflated rubber “flue former” sized to match your appliance capacity. Multiple flues can be created within a single large chimney, and flues that bend up to 45 degrees can also be lined. Another system utilizes stainless steel pipe inserted in the chimney and surrounded with vermiculite.

A thimble may be permanently cemented into the chimney to facilitate removal of the connector for cleaning. Leave a small gap between the thimble and the wall-covering material to allow either the house or the chimney to settle slightly and not crack the thimble. The gap can be covered with a decorative flange (figure 6–2).

If no thimble is used, securely fasten the chimney connector to the chimney with high-temperature cement. It must extend flush with the inner face of the liner. In both cases, remove combustible material within 18 inches of the pipe. For a 6-inch-diameter pipe, this requires a 6-inch + 2 x 18-inch = 42-inch-diameter opening in a combustible wall. The opening may be closed in or covered with noncombustible

materials such as masonry or sheet metal. Refer to the International Mechanical Code for systems that allow reduced clearances (see table 5–3, page 30).

Chimney Requirements

An existing masonry fireplace should meet the following standards:

- Brick or concrete chimney walls must be at least 4 inches thick and have a flue lining. Walls of stone chimneys with a flue liner must be at least 12 inches thick.
- All masonry chimneys should have an intact fireclay liner at least $\frac{5}{8}$ inch thick to keep the chimney smoke-tight and prevent overheating of the chimney wall. Creosote stains on the chimney's exterior or smoke coming through the interior chimney wall suggests a liner damage or cracked masonry.
- All mortar joints should be solid. If you can probe with an awl into the mortar joints more than $\frac{1}{4}$ inch, have the chimney repaired.
- Unused thimbles are a problem with old masonry chimneys. It is common to find thimbles connecting the chimney flue to every room the chimney passes through. Often these thimbles are covered with metal plates and then paneling,

plaster, or wallpaper. Not only will they conduct heat to combustible materials, but they could also pop out during a chimney fire. Locate all thimbles, and fill them with mortar and masonry built up to the same thickness as the chimney wall.

- Where the fireplace chimney passes through floors and ceilings, be sure the 2-inch clearance between the chimney and surrounding wood structure is fire-stopped with a noncombustible material such as sheet metal.

Two or More Connections to One Chimney

The International Mechanical Code and NFPA-211 do not allow connecting a solid-fuel stove to a flue serving appliances burning other fuels. There are three reasons for this rule. First, each time the furnace shuts off, a small amount of unburned fuel enters the chimney. A spark from the woodstove could ignite the gas and cause a small explosion. Second, the chimney is often not large enough for proper operation of the two heaters. Third, gases from one unit may come into the house through the other unit so that dangerous fumes may accumulate in the house.

The standard does have an exception, though. If the gas or oil appliance is listed for such an installation and is installed according to the listing, it may be connected to the flue.

Chimney Caps

A chimney cap is sometimes used to help prevent downdrafts where the chimney top is subject to wind turbulence caused by roof shape, trees, terrain, or other buildings, as well as to keep out rain and snow. Any cap adds resistance to the system and reduces draft. Often the disadvantages outweigh the advantages, and caps are not used. If a cap is necessary, a removable flat disk cap is simple to install and slows gas flow very little.

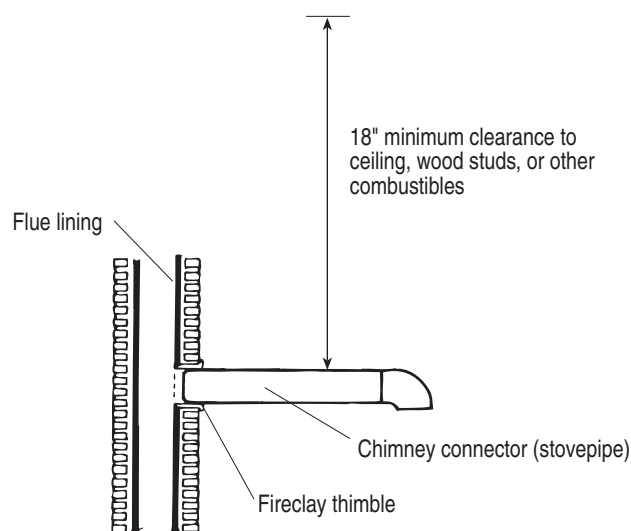

Figure 6–2. Chimney connection

Chimney Height

The codes suggest that chimneys extend at least 3 feet above flat roofs, and at least 2 feet higher than any point on a pitched roof within 10 feet of the chimney. In locating and designing the chimney, consideration should be given to system performance. Avoid locations that will create short chimneys (under 15 feet), as adequate draft may not be developed. Also avoid a chimney location that can be affected by other higher sections of the house, trees, or other buildings. These may create wind turbulence resulting in downdrafts. Installations at high altitudes require greater draft (figure 6-3).

The flue lining of a masonry chimney should extend 4 inches above the top course of brick or stone. Two-inch-thick cement mortar at the outside edges of the chimney top and sloped to the flue lining directs air currents upward at the top of the flue and drains water from the top of the chimney.

Chimney Inspection

Inspect stovepipes and chimney flues frequently for creosote buildup, especially during the first wood-burning season. One method for checking stovepipes is to tap on the pipe with a metal object. The sound will change from a metal ping to a dull thud as materials build up inside the pipe. Usually creosote buildup is

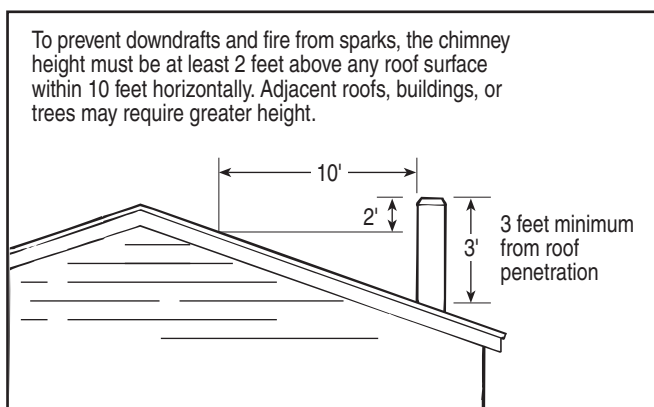

Figure 6-3. Chimney heights

greatest in the horizontal sections of the stovepipe. The chimney may be inspected from the roof. If you use a controlled-combustion stove, check the stovepipes frequently (weekly) until you gain experience with the stove.

Chimney Cleaning

Chimney cleaning prevents chimney fires and improves the draft. How often a chimney needs to be cleaned depends on how frequently the stove is used and how it is operated. Some need cleaning only once or twice a year; an improperly operated stove can plug up a chimney in a week. Any time an inspection shows a $\frac{1}{8}$ - to $\frac{1}{4}$ -inch-thick layer of soot or creosote, the chimney should be cleaned.

One of the advantages of coal over wood is the absence of a creosote problem. However, burning coal does deposit fly ash and particles of solid carbon in the stovepipe and flue. This soot reduces the heat value of the fuel by interfering with the draft, and can hold sulfuric and hydrochloric acids along the flue pipe and chimney. This corrosive mixture can cause rapid deterioration of steel chimneys and slower deterioration in masonry chimneys. While not as readily flammable as creosote, soot can ignite and fuel a chimney fire, which could damage the chimney or spread to other parts of the house.

Chimneys are usually cleaned by mechanical means to scrape off any loose creosote buildup. Stiff chimney-cleaning brushes constructed to match the size of the chimney flue are pushed through the chimney with extension rods or pipe, or pulled with ropes on either end of the brush. In some cases a weight attached to the bottom of the brush will drag the brush to the bottom of the chimney, from where it is then pulled up with a rope (figure 6-4).

If you clean the chimney, be very careful when climbing on high, steep roofs. You may instead want to hire a chimney sweep who has the proper safety equipment

and is knowledgeable in chimney inspection. Many professionals carry large vacuum cleaners to clean up the soot.

Fireplace flues present additional cleaning problems. Where possible, remove the fireplace damper so scrapings do not lodge behind it during the cleaning. Then cover the fireplace opening by taping a plastic cover over it. **Be sure to clean or vacuum the smoke shelf above the fireplace where scrapings accumulate.**

Chemicals such as sodium chloride or table salt are sometimes used as chimney cleaners. The chemical combines with water released from a hot fire to form a weak acid that dissolves small amounts of creosote. Some chemicals may corrode metal chimneys and stove parts. Some of the newer chemical products have proven more effective in chimney cleaning and even in removing glazed creosote. They must not be used in catalytic woodstoves because they will damage the catalytic converter.

Do not rely on chemical chimney cleaners alone. If chemicals are used, check that they are noncorrosive, and continue frequent inspection.

Heating System Maintenance

Following these basic maintenance routines will help ensure a properly operating system, as well as minimize risk of fire.

Daily

Check the ash level, and remove ashes when they start to build up.

Weekly

Use a wire brush to clean the heater's interior and flue when soot builds up to a $\frac{1}{8}$ -inch thickness. A buildup of soot and ash on the inner surfaces of the stove or furnace and stovepipe acts as an insulator, inhibiting the transfer of heat to the house.

Monthly

Check stovepipe for soot and creosote; clean if it is greater than $\frac{1}{8}$ inch. Inspect and clean furnace air filters. Clean and lubricate bearings in blowers and fans.

Seal any cracks between stovepipe connections and castings with furnace cement. Draft leaks affect both the operation and safety of the installation.

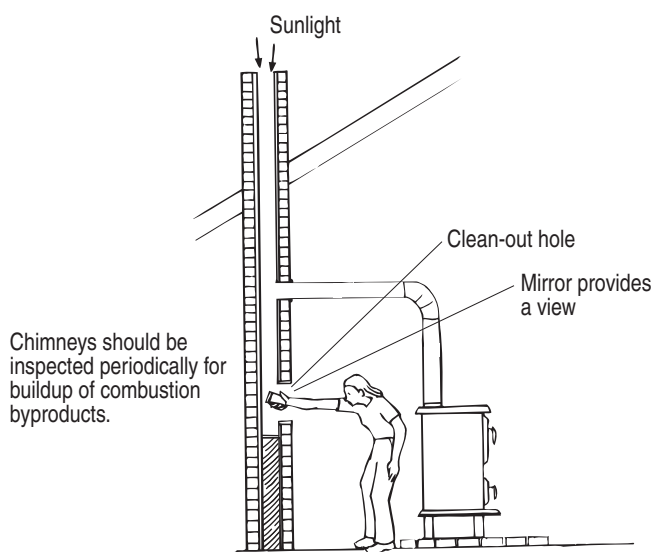

A clean chimney is a safe chimney.

Usually steel wire brushes are used for masonry chimneys and polyethylene brushes for prefabs.

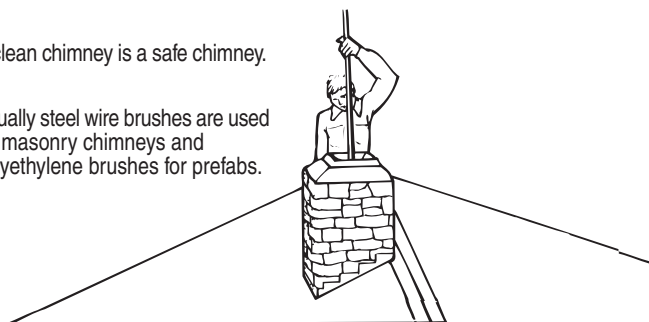

Figure 6-4. Chimney cleaning

End of Heating Season

Have the chimney and stovepipe cleaned. Check operation of heating system controls.

Remove all fuel and ashes, and clean the interior of the stove, or the heat transfer surfaces of a furnace or boiler, for rust protection during the summer. An open coffee can of silica gel inside the heater will absorb moisture.

Chimney Fires

Even with the most conscientious cleaning habits, stove owners still face some danger of fire. A properly installed stove and chimney can withstand an **occasional** chimney fire. Although the ignition temperature of new house framing is about 500°F, over a period of years, as the wood that is near the stove and chimney is repeatedly heated, the ignition temperature may become lower. Care should be taken to reduce the frequency of such fires.

Prepare for a fire by having an emergency plan for family members (figure 6–5). Designate exits and an outside meeting place; discuss special problems you anticipate. Have on hand, and know how to use, several multipurpose (ABC) dry-chemical extinguishers. Locate them between the stove and exit and between the stove and your bed. Install smoke detectors in the vicinity of bedroom areas and near the basement stairs. Be alert to a roaring noise and sparks from the chimney.

When you realize a chimney fire has started, arouse everyone in the house, and start your emergency plan. Get everyone out.

If the fire is restricted within the chimney, close stove openings, draft controls, and dampers to cut the air supply to the fire. Then call the fire department from a cell phone or from a neighbor's home.

As part of your emergency planning, decide how

you would fight a chimney fire. The best attack point would be through the clean-out door of the chimney or through the fuel door.

First open the damper, then **cautiously** open the door. Be careful of flames that may flash back toward you. Step back from the stove, and use a fire-extinguishing chimney flare, available at most stove dealers, or a dry chemical fire extinguisher. To activate the chimney flare, remove the end cap, and scratch the ignition material across the primed end of the extinguisher. Place it inside the firebox, and close the door and drafts. To activate the fire extinguisher, hold it upright, and spray in short bursts until the extinguisher is empty. To avoid breathing fumes from these chemicals, hold your breath for several seconds. Leave the door open for a few seconds to allow the chemicals to be drawn up into the chimney, then close everything again.

If you don't have a fire extinguisher, empty a large box of baking soda on the fire. Sodium bicarbonate is a traditional fire-extinguishing chemical.

The use of water on a hot chimney or stove can crack the stove and damage the chimney. Make dry-chemical extinguishers part of your original stove installation!

After the chimney fire is out, have the chimney inspected by a chimney sweep or mason, and make any needed repairs. If a metal chimney is involved, check for damage. Discoloration or bulges in metal and gaps at the joints can indicate a potential source of future trouble.

Many chimney fires start because the fire in the stove gets out of hand. This can happen if you use your stove as a trash burner or let the flames from a large mass of paper go up the chimney. Many chimney fires result from heavy loading of a stove and then reducing the air supply for a long burn. The wood dries out, the volatiles evaporate, and a full load of material remains to burn fast and furiously.

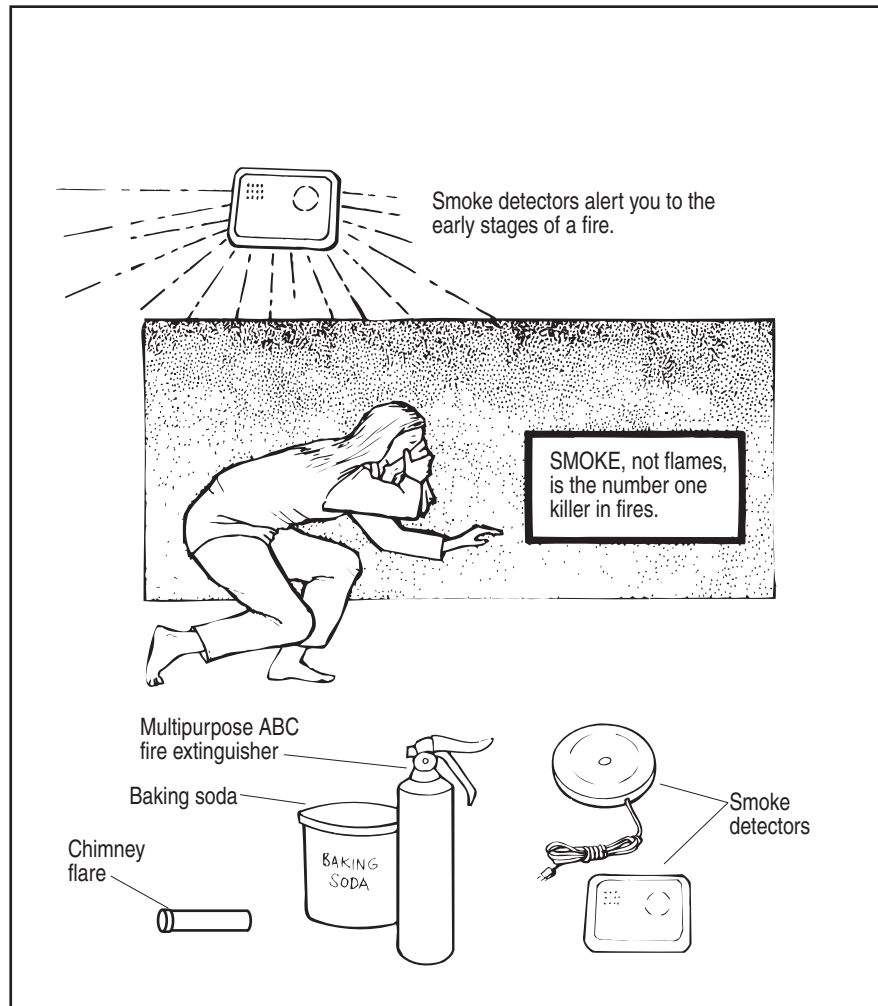

Figure 6-5. Fire extinguishers and smoke detectors should be part of every stove installation

Blank

Chapter 7: Wood as a Fuel

Buying Firewood

Measurement Units

When purchasing firewood, one is often faced with a confusing array of measurement units. Firewood is normally sold by the face or standard cord or by a fraction of a cord (a requirement in many states). A standard cord is a compact stack 8 feet long, 4 feet high, and 4 feet wide (figure 7–1). Be sure you have a clear understanding with the seller, preferably in writing, of the amount of wood being sold. In some states firewood dealers must provide documentation of the amount of wood being sold in cords or tons.

The measurement units include the air space between the sticks. Thus the amount of solid woods depends upon whether the sticks are straight or crooked, round or split, and large or small in diameter. The variation

is considerable, as a standard cord may contain from 60 to 110 cubic feet of solid wood. A commonly used conversion from gross volume to solid wood content of hardwood sticks 3–8 inches in diameter is 80 cubic feet per standard cord. Larger diameters of round wood or split wood, neatly stacked, usually yield more solid wood per cord.

Other factors to consider when buying wood are:

- A standard cord cut into shorter lengths will always stack in less space than originally because many of the crooks are eliminated, and some wood is lost as sawdust.
- A standard cord contains about two to four times as much wood as a face cord, depending on stick length. A face cord is 4 feet x 8 feet x 12–24 inches, depending on the length of wood used in the stove.
- A cord of green wood (freshly cut trees) will shrink at least 8% in volume as it dries during seasoning.

Firewood is sometimes sold by the load or by weight. Of course, the amount of wood in a “truckload” varies greatly depending upon the type of vehicle. A pickup truck with a bed 4 feet wide, 19 inches deep, and 8 feet long will hold one 16-inch face cord. A dump truck may hold up to four standard cords. Large pulpwood or logging trucks with wood racks will hold from six to nine standard cords.

When buying wood by weight, try not to buy water; that is, **look for the driest wood possible**. In general, when dried to about 20% moisture content (air-dry basis), dense hardwoods (oak, hickory, and maple) weigh about 3,500–4,000 pounds per standard cord, while softwoods weigh half that amount. A cord of green wood weighs up to a ton more than dry wood depending on the species.

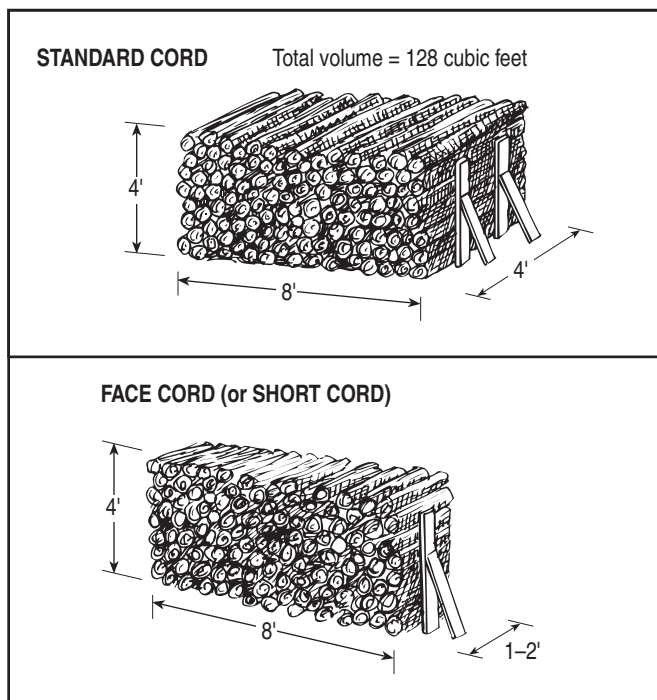

Figure 7–1. Wood measurement units

The price fuelwood dealers charge varies depending upon the amount of wood, species, length of pieces, seasoning, whether it is split or unsplit, whether it is delivered, whether it is stacked on site, and the geographic location. Sometimes one can buy economically by ordering well in advance and in large quantities. Green wood is usually less expensive than seasoned wood. Industrial wood scraps (slabs, trim, and edging) can often be purchased directly from a sawmill or other wood-using business. These sticks are usually small enough for small fireplaces and stoves, or they may be split for kindling.

Heating Value

The heating values per air-dried standard cord of numerous woods compared to other fuels are given in table 7–1. The heat derived from wood combustion depends on the density or concentration of woody material, resin, ash, and water in the wood. The first three features vary depending on the tree species and its growth rate, while the latter depends on the species, the season in which the tree was cut, and the seasoning procedures used. In general, the heaviest or most dense woods, when seasoned, have the greatest heating value. Lighter woods give about the

Table 7–1. Heat value of various woods compared to other fuels

A CORD OF AIR-DRIED WOOD	=	TONS OF COAL	GALLONS OF FUEL OIL	THERMS OF NATURAL GAS	KILOWATT HOURS OF ELECTRICITY
Hickory, hop hornbeam (ironwood), black locust, white oak, apple		0.9	127	174	3,800
Beech, sugar maple, red oak, yellow birch, white ash, black walnut		0.8	115	160	3,500
Gray and paper birch, black cherry, red maple, tamarack (larch), pitch pine		0.7	99	136	3,000
American elm, black and green ash, sweet gum, silver and bigleaf maple, red cedar, red pine		0.6	90	123	2,700
Poplar, cottonwood, black willow, aspen, butternut, hemlock, spruce		0.5	75	102	2,200
Basswood, white pine, balsam fir, white cedar		0.4	63	87	1,900

Assumptions:

WOOD: 1 cord = 128 cubic feet of wood and air or about 80 cubic feet of solid wood at 20% moisture content. Net or low heating value of 1 pound of dry wood is 6,200 Btu. Efficiency of the burning unit is 50%.

COAL: Heating value is 12,500 Btu per pound. Efficiency of the burning unit is 50%.

FUEL OIL: Heating value is 138,000 Btu per gallon burned at an efficiency of 75%.

NATURAL GAS: One therm = 100,000 Btu = 100 cubic feet. Efficiency of burning is 75%.

ELECTRICITY: One kWh = 3,412 Btu. Efficiency is 100%.

same heat value per pound as heavier hardwoods, but because they are less dense, they give less heat per cord or cubic foot.

Cutting Your Own Wood

The romantic notion of “firewood gathering” should actually be thought of as timber harvesting. It may indeed be healthy exercise, but it is also one of the most dangerous professions in the United States. Proper education on safe chainsaw and ax operation and proper tree-felling techniques cannot be learned entirely from a book or film; only many hours of supervised practice will suffice. Appendix A: Cutting Firewood with a Chainsaw (page 63) will introduce you to some of the basics of safe chainsaw operation.

For those owning a woodlot, cutting trees for firewood can improve the quality and rate of growth of the remaining trees, and it is the least expensive means of obtaining firewood. But cutting trees is dangerous work that takes personal time and a vehicle for hauling. It generally takes about four to ten hours of work to ready a standard cord of wood for the fire. The beginner may take longer.

A typical woodlot has a sustaining yield of about $\frac{1}{2}$ cord per acre per year. A tree with a diameter at breast height (dbh) of about 15 inches will generally yield $\frac{1}{2}$ a standard cord— $\frac{1}{4}$ cord from the trunk, and $\frac{1}{4}$ cord from the branches. A 20-acre woodlot can easily provide a continuous supply of firewood for most households.

To obtain the most economic value from future sawtimber sales, cut low-value trees that will give more room for the growth of the best remaining trees in the woodlot (figure 7–2). Crooked trees with many branches are often the trees that should be removed for firewood, although they require more time and energy per volume of wood produced and support a more diverse wildlife habitat. Utilize diseased, dead, and otherwise damaged trees, unless wildlife habitat

is an ownership objective. Many birds and animals rely on trees with cavities for nesting and den sites. Sometimes, of course, straight trees are removed to reduce crowding of equally good or better trees. Try to space future timber trees so that their crowns are 3–5 feet apart. It is best to seek guidance from a professional forester before harvesting any timber. The forester can provide you with local harvesting regulations.

The art of “culling” or thinning a woodlot requires good judgment. Woodlot owners unfamiliar with woodlot improvement techniques and sawtimber management may obtain technical advice and service through the state conservation department, the state forester, an extension forester, or a consulting forester.

If you do not own a woodlot, it is sometimes possible to buy cutting and salvage rights on municipal, state, federal, or privately owned lands at a nominal cost.

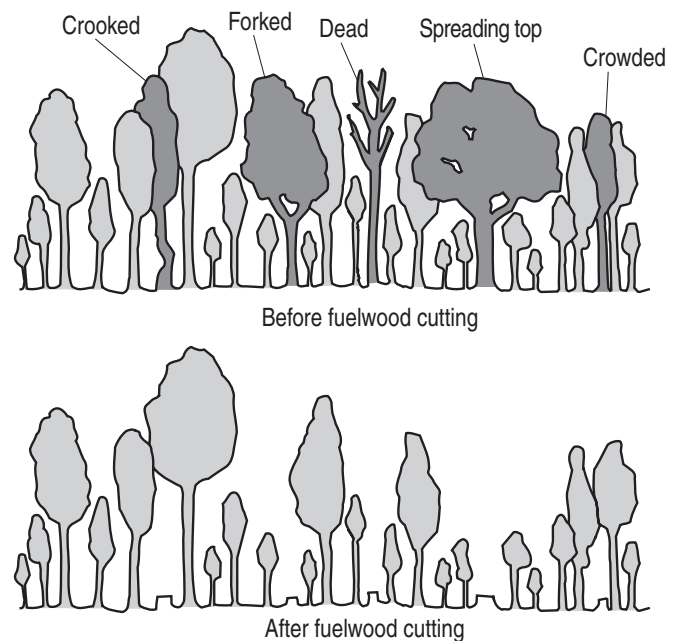

Figure 7–2. Improve the sawtimber value of your woodlot while gathering fuelwood

Some of these cuttings involve thinning public woodlots, while others are salvage operations in logged areas. Utility company rights-of-way, land-clearing operations, and areas that have recently been logged are other sources to be considered. Generally, the distance that a person is willing to hand-carry wood to a road dictates the extent of public thinning operations. Some state agencies and private companies have limited firewood sales due to limited accessibility.

Be resourceful. Look for as many sources as possible for your fuel supplies. But start early—the fall is not the best time to work up a firewood supply for the forthcoming winter. Try to cut your wood six months to a year ahead. Keep it under cover, and it will burn much better. Remember, wood needs to properly season before it is burned.

Characteristics of Wood

When considering the type of wood to burn, other characteristics in addition to heat value are often important. These characteristics include ease of splitting, ease of ignition and burning, extent of smoking, extent of sparking, and coaling qualities, or the ability to form long-lived coals. Table 7–2 lists the characteristics of commonly used fuelwoods. Moisture content of the wood and the number of knots also affect these characteristics.

If you cut your own firewood or split kindling and logs, the splitting characteristics of wood are very important. Short lengths of straight-grained, knot-free wood will split easily. Green wood and softwoods usually, but not always, split more easily than dry wood and hardwoods. Sometimes frozen wood splits easily. Straight-grained cottonwood, aspen, fir, and pine split easily and are best for kindling, although the high content of resin in this wood leads to “sparking” when heated. In contrast, woods with interlocking grain, such as American elm and sycamore, may be very difficult to split.

Softwoods

Softwoods, being resinous, are easy to ignite and burn rapidly with a high, hot flame. However, they burn out quickly and require frequent attention. Some resinous softwoods, such as cedar, juniper, larch, hemlock, and spruce contain moisture pockets that can be troublesome. Upon heating, trapped gases and water vapor build pressure in these pockets resulting in “pops” that throw sparks. Such sparking can be a potential fire hazard, especially in fireplaces without proper screens. Sparking is another reason to reduce the moisture content of wood as much as possible before burning.

Hardwoods

Hardwoods are generally more difficult to ignite, burn less vigorously and with a shorter flame, but last longer and produce more coals than softwoods. White birch typically is easy to ignite because of its papery, resinous bark. Oak gives the most uniform and shortest flame and produces steady, glowing coals. Hardwoods have a greater Btu output and less creosote formation.

Artificial Logs

Artificial logs (composites of sawdust, chips, wax, chemicals, and starch binder) are used in fireplaces for their convenience and ease of starting. Most of these logs should not be burned in a stove, as their combustion characteristics and gaseous output are considerably different from wood logs. Be sure to read and follow the log manufacturer’s instructions.

Pellets

Pellets are manufactured from hardwood and softwood waste and biomass. Due to the low moisture content, high density, and high heat value, less storage space is needed per year as compared to firewood. Pellets also require less handling and less time tending the fire. The standard grade has less than 3% inorganic ash content, and the premium grade contains less than 1%. The convenience of burning pellets is offset by

the higher cost, most of which is due to the machinery needed and the distance they are shipped.

Seasoning and Storing Wood

Eliminating moisture from firewood before storing it indoors or burning it greatly reduces potential insect pest nuisances, firewood ignition problems, and creosote buildup in the chimney. Any moisture in the wood reduces the recoverable heat, because water absorbs heat in the process of being changed to steam. When air-dried under cover, most types of wood will reach approximately 20% moisture content.

The moisture in the wood of living trees varies among species, within species, and even within a single tree. Frequently, there is a significant difference between the quantity of moisture contained in the central column of heartwood of a tree and the outer layer of sapwood, which is surrounded by bark. For example, freshly cut American beech has been found to have a heartwood moisture content of 72%. In contrast, heartwood moisture contents in American elm, northern red oak, and white ash are 95%, 80%, and 46%, respectively.

Table 7–2. Characteristics of commonly burned woods

SPECIES	SPLITABILITY	EASE OF STARTING	HEAVY SMOKE	SPARKS	COALING QUALITIES
Hardwoods					
Apple	Hard	Hard	No	Few	Excellent
Ash	Medium	Fair	No	Few	Good
Beech	Hard	Hard	No	Few	Excellent
Birch	Medium	Easy	No	Moderate	Good
Cherry	Medium	Hard	No	Few	Excellent
Cottonwood	Easy	Easy	Medium	Moderate	Good
Elm	Hard	Fair	Medium	Few	Good
Hickory	Medium	Fair	No	Moderate	Excellent
Locust, black	Hard	Hard	No	Few	Excellent
Maple	Medium	Hard	No	Few	Excellent
Oak	Hard	Hard	No	Few	Excellent
Poplar, yellow	Easy	Easy	Medium	Moderate	Fair
Sycamore	Medium	Fair	Medium	Few	Good
Walnut	Medium	Easy	No	Few	Good
Willow	Medium	Easy	No	Moderate	Poor
Softwoods					
Cedar	Easy	Easy	Yes	Many	Poor
Hemlock	Hard	Easy	Medium	Many	Poor
Pine	Easy	Easy	Medium	High	Fair–Poor
Spruce, Norway	Medium	Easy	Yes	Many	Poor
Tamarack (larch)	Easy	Easy	Medium	Moderate	Good
Juniper	Medium	Easy	Medium	Moderate	Fair

The greater the surface area without bark that is exposed to air, the more rapid the drying. Short sticks dry more rapidly because moisture moves freely along the grain. Wood greater than 8 inches in diameter or longer than 4 feet dries very slowly. Reduce the size of such sticks by splitting and/or sawing, and stack them in loose piles raised off the ground to increase air circulation.

Seasoning can be accelerated greatly by stacking fuelwood in a sunny location and covering the top of the pile with clear plastic sheeting, sheet-metal roofing, or lumber covered with asphalt tar paper. A solar wood dryer (figure 7-3) will greatly reduce drying time. In sunny weather, temperatures under the cover will rise much higher than outside temperatures, warming the wood and evaporating the contained moisture. The water vapor produced is removed by the wind currents.

A small scale can be used to check if firewood is still seasoning. Weigh a basket or bag of a few pieces of

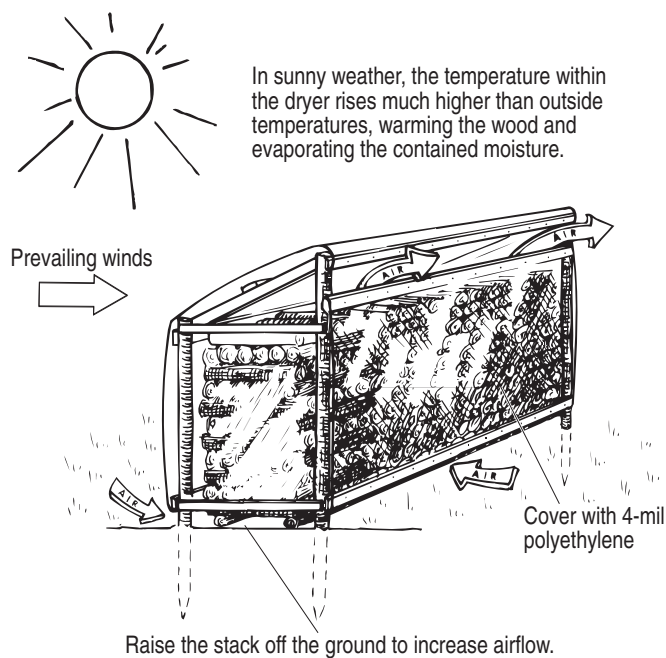

Figure 7-3. Solar wood dryer

firewood. Mark them, and place them back in the woodpile. Then weigh them again in about a month. If they have lost weight, the wood is still drying. Cracks that appear at the ends of logs are good signs that the wood is seasoning.

Generally, wood that is cut during the winter, split, and stacked in the open, preferably with a cover, should be seasoned by the next heating season.

Firewood is best stored outdoors, under cover, and near the house so that valuable space in the house is not used, insects are kept outside, and the dirt problem is reduced. It can be stored in a woodshed (figure 7-4), utility building, garage, or under a sheet of plastic or sheet-metal roofing.

If sufficient space is available under a roof, seasoning and storage can be accomplished in one handling. This practice eliminates the extra handling of moving wood dried outside into a covered storage area.

Outside, wood will dry to between 14% and 25% moisture content, depending on humidity, temperature, and wind. In a garage or woodshed, it may dry to about 18% moisture content; and wood may dry to about 12% in the house.

End braces can be used if you have difficulty stacking wood and if the pile collapses at either end. Constructed with two-by-fours, end braces are like bookends and can be built to accurately measure a standard cord. The planks, two-by-fours, or pallets beneath the woodpile keep the bottom row above wet ground.

In some homes, a wood box can be constructed inside the house, convenient to the woodstove and which has loading access outside.

Operating Techniques

Review the section on combustion in chapter 1. The combustion rate is controlled by the amount of air that is supplied to the fire. With more air, the rate of burn increases, and more heat is generated. The rate of burn is also governed by the size of the fuel. Small kindling wood burns rapidly to start a fire, and large pieces burn slowly to sustain a fire overnight.

If only the exact amount of air needed for combustion were fed to the fire, maximum efficiency would not be

reached. In reality, the air and combustibles cannot be perfectly mixed, so some unburned particles escape without coming into contact with the oxygen. Some excess air, usually 20–50%, is needed to get more complete burning. On the other hand, excess air cools the fire and takes more heat up the chimney.

Creosote

Smoke forms because the combustion process of wood is never absolutely complete. The smoke contains the chemicals that form a dark brown or

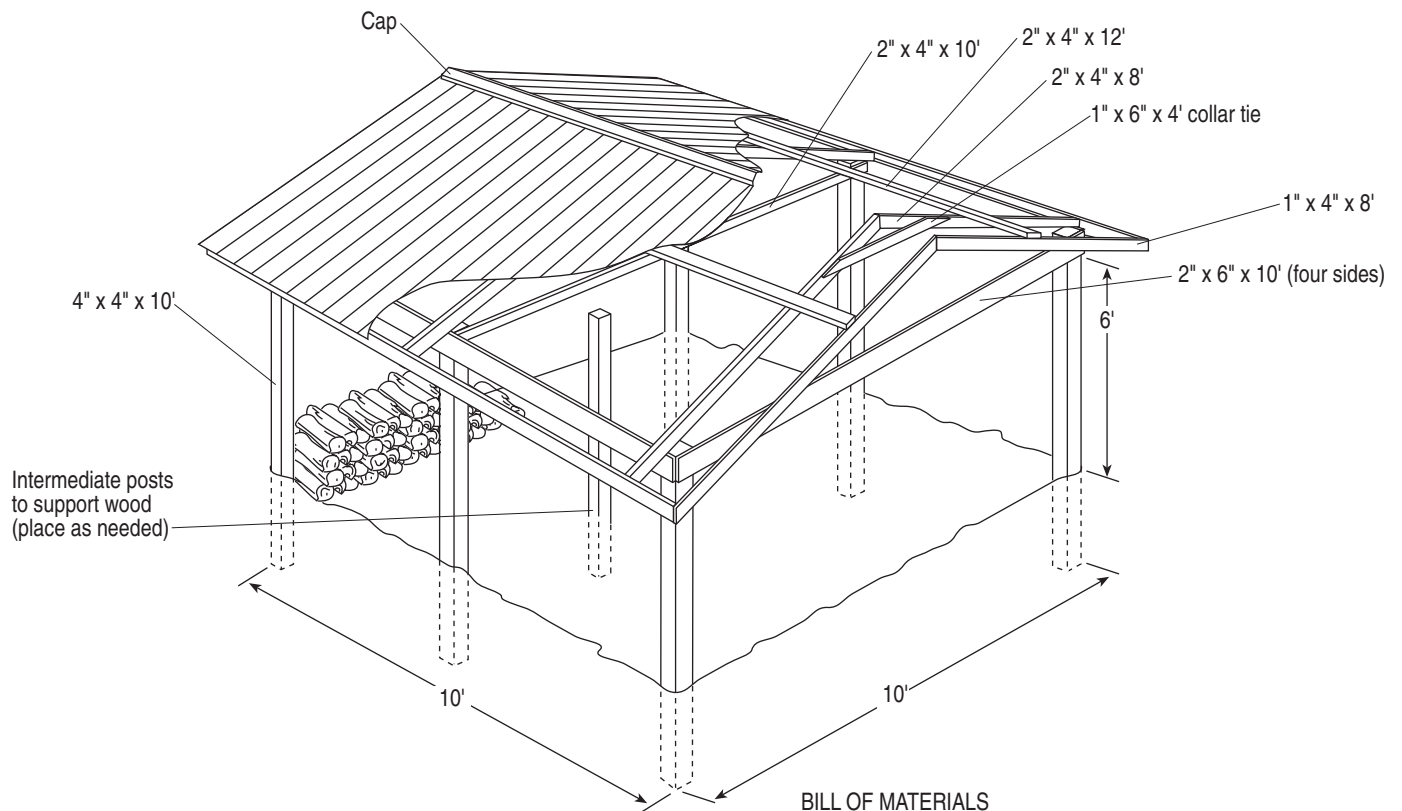

BILL OF MATERIALS

6 pieces	4" x 4" x 10' (pressure-treated)
4 pieces	2" x 6" x 10'
6 pieces	2" x 4" x 8'
8 pieces	2" x 4" x 12'
1 piece	2" x 4" x 10'
4 pieces	1" x 4" x 8'
1 piece	1" x 6" x 12'
	Nails
	192 square feet fiberglass-reinforced plastic or sheet-metal roofing
	12 linear-foot roof cap
	Intermediate posts (if desired)

Figure 7-4. Woodshed for five cords

black substance called creosote, a complex mixture of compounds.

Flue gases leaving the fire cool as heat is absorbed by the stovepipe-chimney system. If the flue gas temperature drops below about 270°F, these unburned volatiles and water vapor condense. In time, the water evaporates, leaving dark, highly combustible creosote on the stovepipe and chimney walls. That is why it is important to burn seasoned wood from which much of the moisture has been removed.

The amount of creosote condensing on the surfaces of the system varies according to the density of the smoke, the temperature of the chimney's surface, and the type and moisture content of the wood being burned. Dense smoke from a smoldering fire is most likely to form large amounts of creosote (figure 7–5).

Ignition of accumulated creosote in the chimney and stovepipe is likely to occur during a very hot fire. A very intense fire results, creating a roaring noise and producing flames and sparks from the top of the chimney. Chimney fires may crack the chimney tile, loosen mortar, and burn the roof; they are not a safe way to remove creosote from a system.

A low or smoldering fire tends to build up creosote. When there is no flame or only a very small flame to ignite the volatiles, these unburned combustibles go up the chimney. When a fire is first started, the chimney surfaces are relatively cool, so creosote accumulates rapidly. When only burning coals remain, little creosote is formed. If you are buying your first wood-burning stove, choose the smaller rather than the larger model. A small stove with an actively burning fire will produce less creosote than a large stove dampered down to restrict rapid burning. Even though a small stove requires more frequent loading, the wood burns more efficiently because the fire is hotter.

Stove design, as well as operation, affects creosote formation. Stoves that have a long flame path are working

to keep the volatiles in the stove and at a high-enough temperature to ignite before leaving the stove. The catalytic stoves and add-ons discussed in chapter 3 are designed to burn volatile gases at lower temperatures and to eliminate most of the creosote problems.

Reduce creosote formation in a stove by the following procedures:

- Open the air inlet to establish a hot fire quickly; then close it to the desired position. Remember that heat is absorbed by the new fuel to heat the wood and drive off water and combustible volatiles. Leave the air inlet open until the new charge of wood is burning well; then restrict inlets to allow continued **active burning** instead of a roaring fire.
- A stovepipe thermometer is a useful and inexpensive device to help you monitor combustion temperatures and reduce creosote formation. It should read above 270°F to eliminate the formation of creosote.

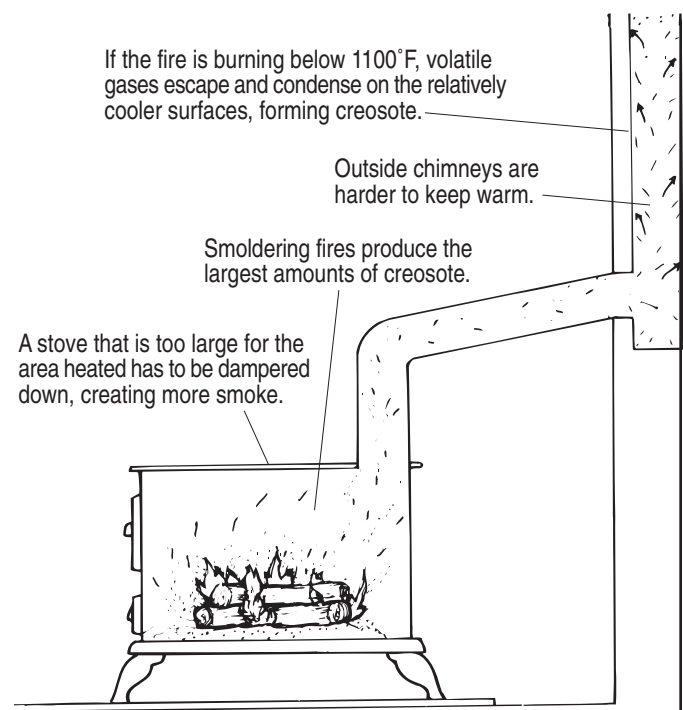

Figure 7–5. Creosote formation

-
- Do not try to increase the time between refueling by restricting the wood's air supply and/or by filling the firebox as full as possible. Add a partial load (about one-third capacity) when refueling. Loading more than one-third of capacity cools the stove, so combustion gases driven from the wood are not ignited and are lost up the chimney. Lengthening the time before refueling tends to increase creosote buildup.
 - Learn how to burn all types of wood. Air-dried hardwood burns best. However, when you must use softwood or wood that is green or wet, mix some dry wood with the green wood.
 - **Starting with a clean chimney**, open all air inlets in an airtight stove for 15–30 minutes every day. The resulting hot fire will safely remove the small amounts of creosote formed in the chimney. **Do not** get the pipe or stove red hot. Follow this practice every day after the chimney is cleaned; an infrequent hot fire can start a serious chimney fire.

The preceding steps encourage you to maintain a hot fire and chimney so that combustion is nearly complete and creosote formation is reduced to a minimum. These practices will sometimes overheat the room, particularly in late spring and early fall. To maintain a comfortable room temperature and make the wood last longer, woodstoves are often operated at reduced draft, so they produce creosote in greater amounts. For better results with moderate outdoor temperatures, burn small pieces of wood to produce a quick, hot fire. Then let it burn out instead of maintaining a slow, smoldering fire.

Stove Operation

Before starting the fire, open the drafts, stovepipe damper, and baffle bypass damper, if present, to allow for removal of the large amount of smoke generated when a fire is started.

If there has been a fire in the stove before, check the ash level. Reduce the ash level on top of the grate or firebox bottom to about 1 inch. The thin ash layer insulates the bottom of the fire and reflects the heat upward. Also, any small pieces of charcoal left from the previous fire will provide heat for the new fire.

To start the fire, lay one larger piece of dry wood along the edge of the firebox. This will contain the fire and reflect heat until the fire is started. On larger fireboxes, two pieces with space between for the newspaper and kindling may work better. Crumple several pieces of newspaper and form a 2- or 3-inch layer over the bottom of the firebox. Avoid slick magazine pages, as they do not burn well. Dry pinecones also work well as a fire starter. Place about a half dozen on top of the paper.

Add a layer of kindling, crisscrossing the pieces so that air and heat can get through. The best kindling is dry softwood, such as pine, spruce, or hemlock. Dead twigs, scrap lumber, and small pieces of pressed logs also work well. The drier they are, the better. Try to keep a good supply under cover at all times. Kindling must be less than 1 inch in cross-section to ignite and burn rapidly. Split sticks work better than round because they have a greater surface area. Before lighting, add one or two larger split pieces on top. Light the paper, and close the door to establish the draft and keep the heat within the firebox. Do not burn pressure-treated lumber or driftwood.

Refueling

When the kindling is burning and after a bed of coals forms, add a few more pieces of dry wood. Again, smaller pieces of split wood will catch more quickly. Leave about 1 inch between pieces to establish flame paths and to reflect heat from one piece to the other to keep up the temperature. **A single large piece of wood does not burn well, because the heat spreads through the piece and radiates away to the metal surfaces of the stove.** The wood surface temperature

does not stay high enough, so the fire does not grow.

If your fire fails, move the logs to one side of the firebox, add more paper and kindling, and relight. The logs should ignite this time, as some drying and charring has occurred, and they are already warm. Do not pour on any flammable liquid, as the glowing embers could cause an explosive fire.

After the fire is burning brightly and you feel some heat from the front, add another layer of wood. Until the stove is fully warmed, use split pieces up to 4 or 5 inches across. Save large pieces for cold weather when the stove will be run at full capacity or when you want to carry a fire overnight. Large chunks burn well when they are placed to one side of the firebox and smaller pieces are fed next to it. The smaller pieces dry out the chunk and eventually turn it to charcoal, which burns with even heat for an extended period.

On manual draft systems, keep an eye on the fire so you can reduce the draft once the unit gets up to temperature. Automatic control systems adjust themselves as the thermostat is satisfied.

If you have been operating a controlled-combustion stove at reduced draft for some time, do not immediately open the door. Open the air inlets and wait for 20–30 seconds before opening the door. Wood burning with a low air supply could cause flames to shoot out through the opening toward the oxygen source. Stand to the side of the door, and keep the door between you and the firebox, if possible.

Smoky Fires

Watch the smoke leaving the chimney when you are burning wood. In a properly operated stove, most of what you see is water vapor, which dissipates within a few feet from the chimney. If the smoke lingers on or trails across to your neighbor's property, the wood is not burning completely.

Six main causes and cures of smoky fires are:

- **Wet wood.** Green or wet firewood causes smoke problems, as much of the heat of the fire is used to dry the wood. The cure is to keep a hot fire going and to use seasoned dry wood. If green or wet wood must be burned, split it finer, and mix it with dry wood. Softwoods may cause smoky fires because of the resin in the wood.
- **Flue too large.** Many older houses have a large central chimney with several fireplaces and flue openings. If this chimney is used with only one stove or heater, the flue gases are cooled rapidly, and there may not be adequate draft to keep the column of smoke rising. By reducing the cross-sectional area of the top of the chimney or installing a stovepipe through the center of the flue, the smoke problem should be solved.
- **Obstructed flue.** Often stovepipes or flues become partially filled with soot and creosote. Cure this problem by checking flues and stovepipes once a month during the heating season and cleaning them when a buildup starts to occur.
- **Downdrafts.** Nearby trees, buildings, or roof projections often cause downdrafts during windy periods. Raising the height of the chimney, removing the obstruction, or placing a cap on the chimney may correct the problem.
- **Lack of oxygen.** A fire needs oxygen to burn properly. In the past, most installations relied on air infiltration from the outside through cracks around doors, windows, and vents. In a tight, well-insulated home, infiltration has been reduced to a minimum. This problem can be compounded if there are several large appliances requiring venting, such as an oil or gas furnace or water heater. This lack of air can sometimes cause smoke to be pulled back into the house through an adjacent flue. Opening a nearby win-

dow an inch or installing a 4-inch-diameter air inlet pipe from an outside wall to near the stove will generally eliminate this problem. Screen the outside of an air inlet, and provide a damper on the inside.

Ash Removal and Disposal

Too many ashes in the firebox restrict airflow and reduce the burning area. A layer 1–2 inches deep is desirable to support the fire and insulate the bottom of the firebox. Excess ash should be removed, usually once or twice a week, depending on the size of ash pan and the use of the stove.

The disposal of wood ash is not a major problem, since the volume of ash is small—about a bushel of ashes per standard cord of firewood. Ash residue is beneficial as a lime substitute for lawns and gardens, as it is high in potash and increases soil pH when applied. A normal application rate is 10 pounds per 100 square feet per year.

Many house fires have started when ashes thought to be cold were placed in a paper or plastic container, and hot embers ignited the container and the house or garage where they were stored. **Store ashes in a noncombustible container away from combustibles.** Hot coals may stay hot and smolder for several days.

Blank

Chapter 8: Coal as a Fuel

Coal is formed from the slow decomposition of vegetative matter subjected for millions of years to heat and pressure underneath the surface of the earth. The changes that take place in the formation of coal result in the production of various intermediate products, as follows: cellulose → peat → lignite → bituminous coal → anthracite. The process through which the cellulose has passed in the formation of coal is known as carbonization.

The combustible portions of coal are fixed carbons, volatile matter (gaseous compounds of hydrogen and carbon), and small amounts of sulfur. In combination with these are noncombustible elements—moisture and mineral impurities that form ash. The various ranks and grades of coal differ in the proportions of these elements and in the heat content (figure 8–1).

Types of Coal

Anthracite (hard coal), the preferred coal for home heating, is hard, compact, and shiny black. It produces little or no smoke in burning and does not soften and fuse together, so firing and ash removal can be automated. Although it is more difficult to ignite, it is longer burning than other coals. Most anthracite comes from a relatively small region in Pennsylvania, so shipping costs limit its use generally to the Northeast.

The coal industry has standardized sizes of anthracite (table 8–1, page 54). Most heating units are designed to burn a specific type and size of coal, the most typical sizes being chestnut (“nut”) or pea for stoves, and stove coal for furnaces and boilers.

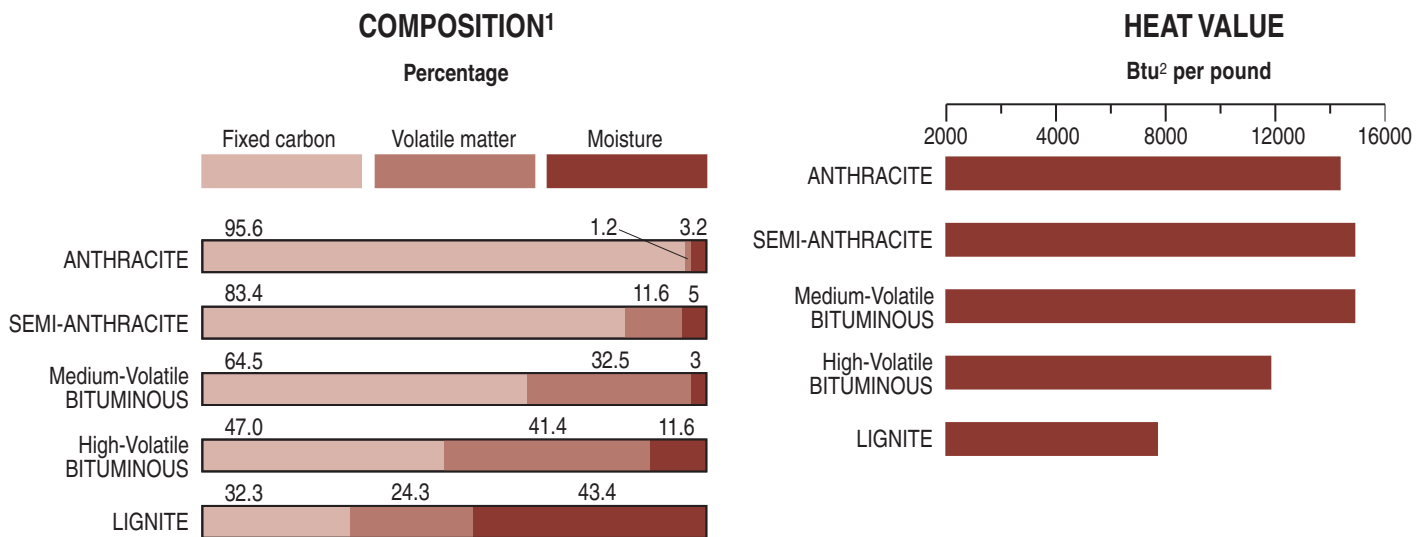

¹ The fixed carbon and volatile matter are calculated on an ash-free basis, because ash in coal varies without regard to rank.

² Btu, or British thermal unit, is the amount of energy required to raise the temperature of 1 pound of water 1°F.

Figure 8–1. Comparison of composition and heat value of various sample coals

Table 8–1. Standardized sizes of anthracite

NAME	SIZE (INCHES)	TYPICAL HEATER
Egg	$2\frac{7}{16}$ –3	Large furnaces and boilers
Stove	$1\frac{5}{8}$ – $2\frac{7}{16}$	Furnaces and boilers
Chestnut “nut”	$1\frac{3}{16}$ – $1\frac{5}{8}$	Stoves
Pea	$\frac{9}{16}$ – $1\frac{3}{16}$	Stoves with hoppers and other stoves in mild weather
Buckwheat, No. 1	$\frac{5}{16}$ – $\frac{9}{16}$	Stoves with hoppers and mechanical stokers

Note: Smaller sizes—Rice (No. 2 Buckwheat), Barley (No. 3 Buckwheat), and No. 4 Buckwheat—are rarely used in domestic heating.

Bituminous Coal

Bituminous coal (soft coal) is not as desirable as hard coal, since it creates dust when burned at a low rate and may contain a high percentage of sulfur. It is found in more areas of the country than anthracite and is, therefore, less expensive in most regions because of lower transportation costs. It is used domestically in areas where it is mined, but its primary use is in electric generation and in industry. Many states have rigid regulations regarding its use.

Cannel Coal

Cannel coal (fireplace coal) is a type of bituminous coal that ignites easily and burns with a luminous, smoky flame. It can be burned in fireplaces but must not be burned in a stove, since it tends to overheat the stove.

Coke

Coke is a high-grade bituminous coal from which the moisture and most of the volatiles have been removed. It has a high heat value, burns clean, and is most successfully burned in stoves and furnaces with large fireboxes. It is not readily available.

Lignite

Lignite (brown coal) is a fuel between peat and true coal. When it is mined, it contains a large percentage of water, sometimes as much as 50%. When dry, its

heat value compares favorably with soft coal. It occurs in immense deposits in North Dakota and Texas.

Purchasing Coal

Buy the exact type and size of coal suitable for your heating unit (e.g., chestnut-sized anthracite). While some stove and furnace manufacturers list the appropriate fuel type and size, many do not. You may have to rely on the advice of a stove or coal dealer or experienced coal burners using the same unit. If you are not sure about the size, purchase a small test quantity before purchasing in bulk.

Buy good quality coal. A written analysis of the characteristics of the coal you intend to buy may be available from your coal retailer. Even among the high-rank anthracites, you may have high ash content or low ash-fusion temperature.

Quality coal has the following characteristics:

- **Low ash content.** Having less ash means more combustible fuel per unit of volume, less frequent ash removal and disposal, and more heat per dollar spent. Two to 5% is excellent; 5–10% is good; 10–12% is fair. Avoid anything over 10% ash content.
- **Low sulfur content.** The lower the sulfur content the better. Sulfur combines with oxygen in the stove to form sulfur dioxide and sulfur

trioxide, which react with moisture and oxygen in the air to produce an airborne sulfuric acid. It is harmful to humans and vegetation, corrosive to stovepipes, and harmful to the strength of mortar in unlined brick chimneys. Sulfur content varies between 0.4 and 5.5%; below 0.6% is satisfactory.

- **High ash-fusion temperature.** A high ash-fusion temperature minimizes the formation of “clinkers,” or fused ash, which can block the grate and increase the amount of labor involved in tending the fire. An ash-fusion temperature above 2,500°F is preferable and usually obtainable in better quality anthracite.
- **Low volatile matter.** Volatile matter will ignite and be converted to heat only under the proper conditions. If this matter is not oxidized, it will be released as pollutants into the atmosphere.
- **High fixed-carbon content.** Fixed carbon is the carbonized residue (coke) that remains after the volatile matter has been driven off. Anthracite is the highest in fixed carbon, in the range of 80–98% on an ash-free basis.

Quantity

To estimate the amount of coal required per heating season to completely replace your present heating fuel, subtract the present annual fuel used for cooking and hot water, and refer to table 8–2.

Prices vary depending on the quality of the coal, the distance from the source of supply, and the means of transportation. Discounts are sometimes available if the coal is purchased well in advance of the heating season. Compare the price of coal among dealers; often there are significant differences.

At cash-and-carry coal yards, there is approximately a 30% savings if the customer bags and transports the coal, or provides the necessary vehicle for hauling bulk coal. Some dealers bag the coal in sizes ranging from 10–100 pounds; this convenience will substantially increase the cost. Handling the coal in bags reduces the amount of coal dust and is a convenient unit to move from storage to the heating unit. An additional fee for home delivery is common; some dealers will not deliver bulk coal in amounts below 2 tons.

Storage

Bulk coal can be stored indoors or outdoors, but any outside storage should be protected from precipitation; otherwise the coal will freeze together and be difficult to remove. Do not store wet and dry coal together.

A basement storage bin is one of the best storage arrangements (figure 8–2, page 56). A hinged or sliding door in a window opening facilitates loading by dump truck with a coal chute. Provide access for delivery

Table 8–2. Approximate coal equivalent of present heating fuel

Multiply gallons of **No. 2 Fuel Oil** by 0.006 to get number of tons of coal

Multiply therms of **Natural Gas** by 0.0043 to get number of tons of coal

Multiply gallons of **Propane** by 0.0038 to get number of tons of coal

Multiply kilowatt hours of **Electricity** by 0.00014 to get number of tons of coal

Multiply cords of air-dried **Hardwood** by 0.8 to get number of tons of coal

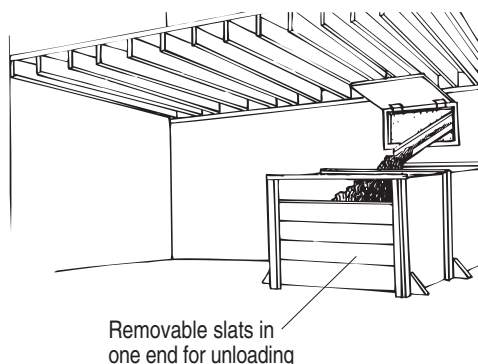

A basement storage room or bin with loading access through a window is a convenient storage arrangement.

Figure 8–2. Coal storage bin

trucks within 10 feet of the storage. You can expect the inevitable coal dust in the basement, so construct the bin carefully, and seal openings.

Coal requires 33–40 cubic feet of storage per ton. A storage bin 4 feet square and 4 feet high will hold approximately 2 tons. Generally more space is allowed so that another delivery can be made before the bin is completely empty.

Bagged coal is easier to handle and can be stored in any dry place. Place the bags off the floor on a pallet or planks.

Operating Techniques

General Operating Procedures

Size and Type of Coal

Always follow the stove manufacturer's instructions regarding the type and size of coal to burn, as well as the method of operation. These instructions are usually based on the manufacturer's tests and experience with the type of coal available in the area where the stove was built. Many manufacturers of coal stoves recommend anthracite only. Warranties often do not apply when types of coal other than those recommended are burned. **Do not** burn cannel coal in stoves,

furnaces, or boilers, as the volatile gases may cause dangerous explosions.

Stoves designed for the lower ranks of coal generally have large fireboxes and provisions for supplying more secondary air, compared to a stove for anthracite giving the same heat output. Furnaces or boilers with stokers are designed to burn either bituminous coal or anthracite, and the fuels cannot be switched. They generally require a small-sized coal (Buckwheat No.1).

Seasonal Operation

In the spring and fall, it is difficult to maintain a low heat output; either the house will overheat, or the fire may go out and require the tedious process of relighting. If the coal stove is used to supplement a central heating system using another fuel, you may choose to operate the coal stove only during the coldest part of the winter.

Another option would be to use wood in the stove during the milder part of winter; but to a lesser extent, the same problem of overheating versus low efficiency occurs with wood. If wood will also be burned, the operator must learn different techniques for proper wood combustion, and be aware of creosote problems.

Controlling the Rate of Burn

Do not attempt to decrease the heat output by reducing the amount of coal in the firebox. A deep charge of coal will give even heat and a long fire; it may take several hours before the whole bed is ignited. If the fuel bed is too shallow, the primary air will pass too quickly through the fuel and fail to break into tiny streams of air necessary for proper mixing with coal gases.

Increasing the fuel bed depth, decreasing the size of the coal used, or less frequent ash removal will cut down the airflow and produce a lower heat output when required. It is also important that a coal heater

not be filled with excess coal that might block the flue gas exit and cause carbon monoxide to enter the house.

Coal responds slowly to changes in draft settings. When a change in heat output is needed, make a small change in the setting, and wait for the temperature to stabilize.

Breaking in a New Stove

Break in new stoves slowly. If possible, light a small initial wood fire in the stove while it is outside to burn off any oils and their fumes. Once the stove is installed, a few wood fires and then a small coal fire will allow the cast iron to cure.

The Overheated Stove

Keep the ash-pit door closed, except during the start-up period, or overheating can result. If a stove is left with wide-open dampers, the stove and stovepipe can become red-hot, and the intense radiation may ignite nearby combustibles (figure 8-3).

If the stove or stovepipe becomes red-hot, adjust the dampers to reduce the air supply, but do not close the dampers completely. Allowing the stove to cool gradually will prevent further damage from thermal stress. **Never** use water to cool the stove, as this will increase thermal stress and likely damage the stove irreparably.

Ashes

Always protect the stove grate from direct contact with the fire by a layer of ash 1-2 inches thick to prevent grate overheating and keep unburned coal from dropping through the grate openings.

The single most common problem with coal stove operation is insufficient shaking and ash removal (figure 8-4). Shake down the ashes whenever the ash accumulation on the grate is excessive; generally once or twice a day is sufficient. If the ashes build up

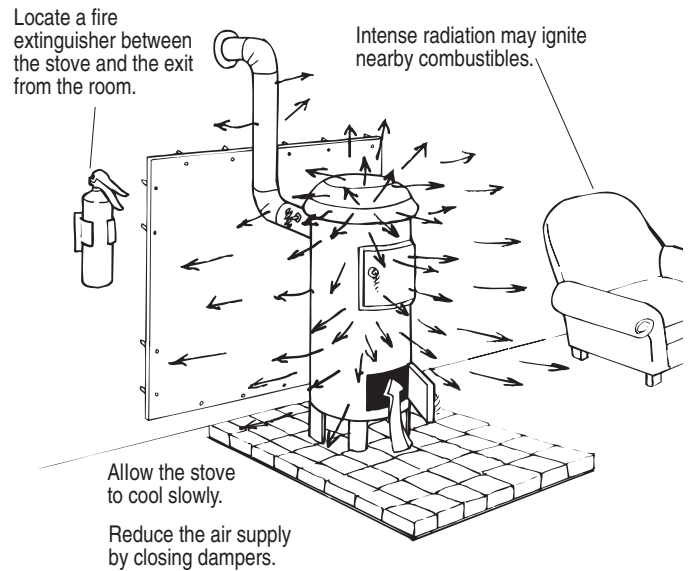

Figure 8-3. The overheated stove

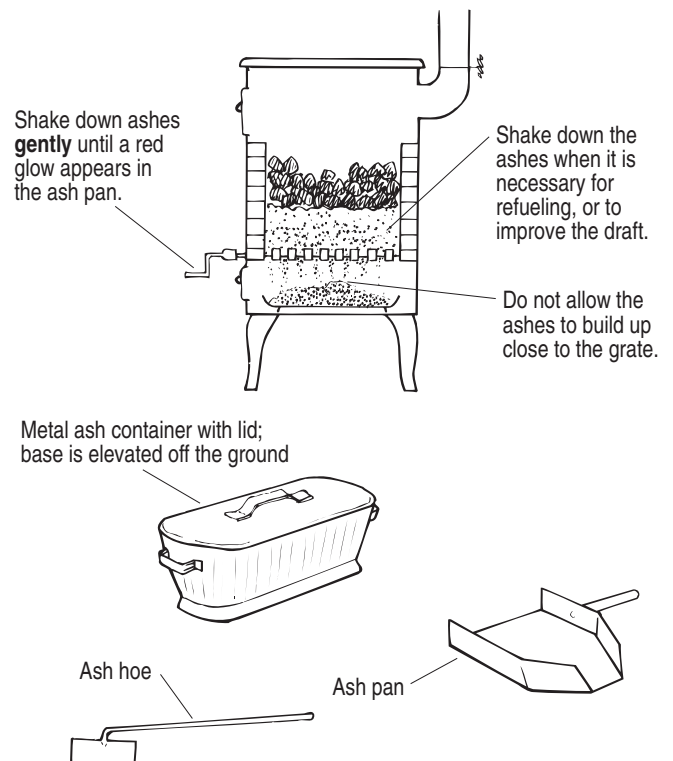

Figure 8-4. Ash removal

excessively, they eventually block the grate, inhibit the airflow, and put out the fire. If ashes are allowed to accumulate in the ash pan up to the grates, normal cooling of the grates is restricted, and this may cause their premature failure.

Shake the ashes down **gently**. The objective is to remove the ashes without disturbing the fire. Use a few short strokes and stop when the first red coals appear. Shaking down more than necessary after a long burn, usually in the morning or evening, is a good way to lose a fire through cooling. Also, poking and disturbing the fire tends to promote the formation of clinkers or fused ash, which block the draft, will not burn, and must be removed before refueling.

Remove ashes whenever the ash pan is nearly full. Do not let the pan overflow so the ashes are touching the grate. Any unburned coal that falls through the grate may be screened out through a piece of $\frac{1}{4}$ - or $\frac{3}{8}$ -inch hardware cloth. Store ashes in a metal container with a tight lid, and place it on a noncombustible floor or on the ground away from combustibles. Hidden embers may be present in the ashes. Coal ashes may have minerals detrimental to the soil, so they should not be used as mulch, soil conditioner, or fertilizer, as can wood ashes.

Clinkers

Clinkers are hard pieces of fused ash that form in the firebox. They can become large enough to inhibit the airflow and cause the fire to die. Once large clinkers are formed, they can be removed only from above the grates.

Clinkers are caused by a variety of conditions, the most important being poor-quality coal with excess ash content and/or low ash-fusion temperature.

Other causes of clinker formation are too hot a fire; too shallow or too deep a fuel bed; excess shaking or poking, which tends to mix the ash and molten coal;

and rapid adjustment of draft from high to a very low setting.

Burning Anthracite

Establishing the Fire

All coal fires must be initially started from the coals or embers of a wood fire or from charcoal. Wood ignites at 550°F, and anthracite ignites at 925°F, so building the fire slowly and patiently will produce the best results. Once the fire is established, the initial fire building need not be repeated for weeks, or even months, if the fire is properly maintained.

Leave a layer of ash on the grate, open the drafts, and build a wood fire. The best type of fire results from a mixture of paper, finely split softwood, and some hardwoods built carefully with air spaces. After 10–20 minutes, when the fire is burning briskly, add a very thin layer of dry, room-temperature coal, being sure to leave visible red spaces between the pieces of coal. Adding the coal too soon, or adding too much coal, could smother the fire. Leave the dampers open until this initial load of coal has definitely ignited and started to glow. When the coal has ignited, blue flames will appear above the bed of coals; this indicates that the volatile gases are being burned with secondary air (figure 8–5).

Now add another single layer to the fire, and close down the primary air supply to a low-to-medium setting. When a uniform bed of bright coals is distributed across the grate, fill the firebox up to the fire loading door, making sure to leave some red coals exposed to help ignite the gases given off by the new charge. Some people find it easier to build up the fire in three or four thin layers.

Maintaining the Fire

Once the fire is self-perpetuating, leave the drafts and flue damper only slightly open to permit slow, complete combustion. Anthracite has a small percentage of volatile matter. After a few minutes, these volatiles

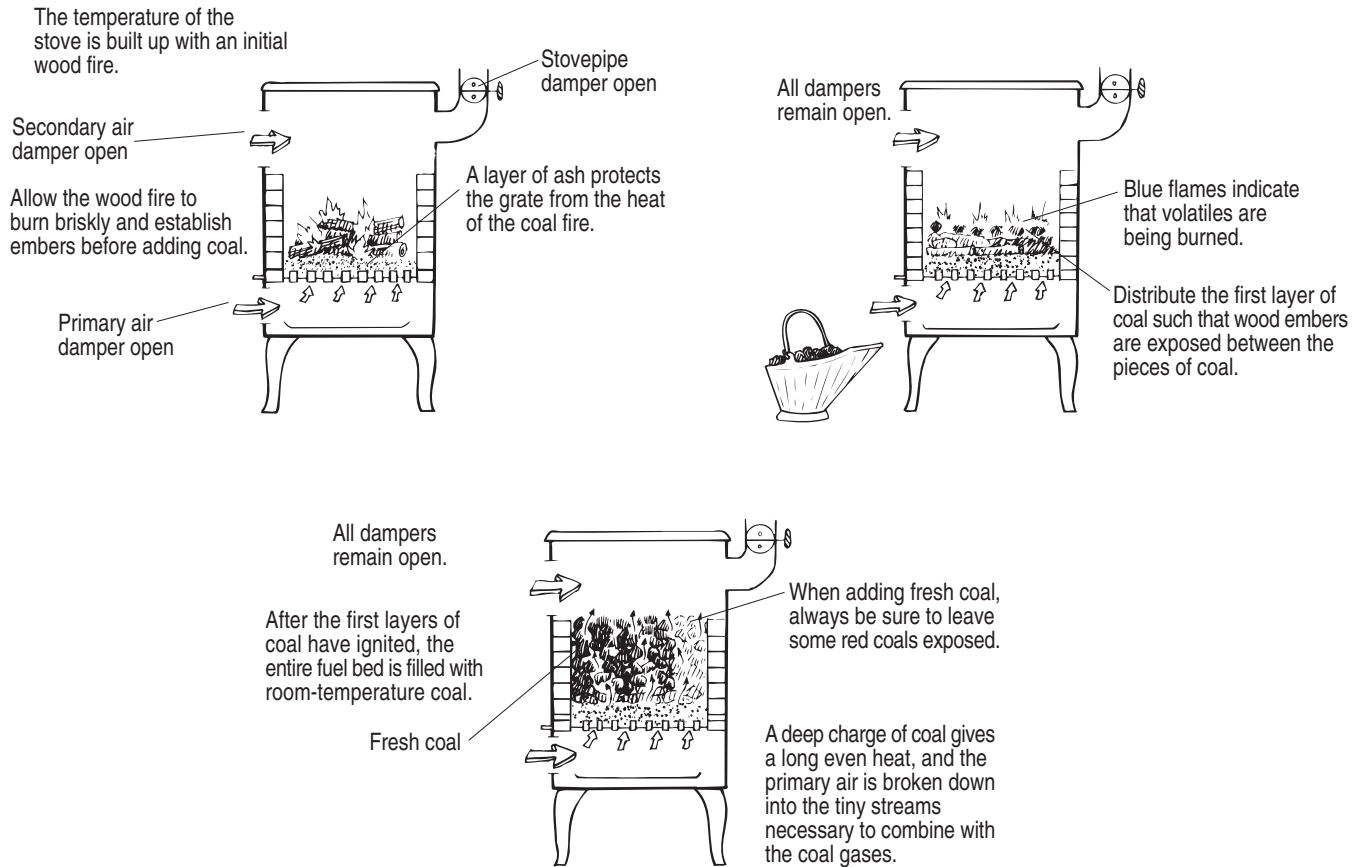

Figure 8-5. Establishing an anthracite fire

will be released; the coke or fixed carbon that remains requires very little air to burn, so the primary draft and stovepipe damper can be almost closed (figure 8-6). Keep the secondary air inlet slightly open to provide oxygen to change carbon monoxide to carbon dioxide. A small blue flame above the coal bed indicates that the volatiles are being combined with oxygen.

Refueling

If the fire is burning hot and there are several inches of bright coals, a full load of coal can be added. However, if there is not a deep bed, do not shake down the ashes until the fire has been built up with small amounts of coal.

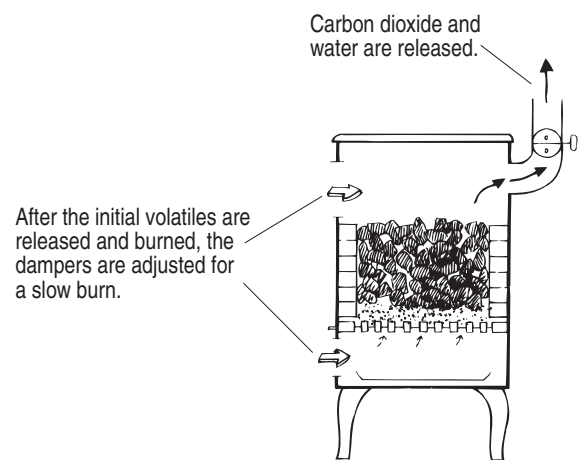

Figure 8-6. Maintaining an anthracite fire

Before opening the fire door, open the dampers to allow the fire to pick up a little and burn off any remaining gases. Check to see if it is necessary to shake down and remove ashes.

When refueling, always leave a portion of the red-hot coal exposed on the top. Scrape some of the red-hot coals toward the back, and add the new charge of coal to keep the fuel level. In this way, all carbon monoxide and unburned volatile matter from the new coal will be ignited as it passes over the coals.

If your stove has a hopper, fill it before the coal level drops to the bottom. When this is done, no adjustment of the draft controls is necessary.

Preparing the Fire for a Long, Slow Burn

To prepare the fire for an overnight or long burn, shake down and remove excess ashes, and open the drafts to ignite the new charge. Draw the red-hot coals to the front of the firebox, and bank or heap fresh fuel up the sides and back of the stove to cause more gradual burning (figure 8–7). Using a smaller size of coal will also reduce the combustion rate by impeding the flow of air. Allow the fresh fuel to establish itself and burn off volatiles, then adjust the dampers for a slow burn.

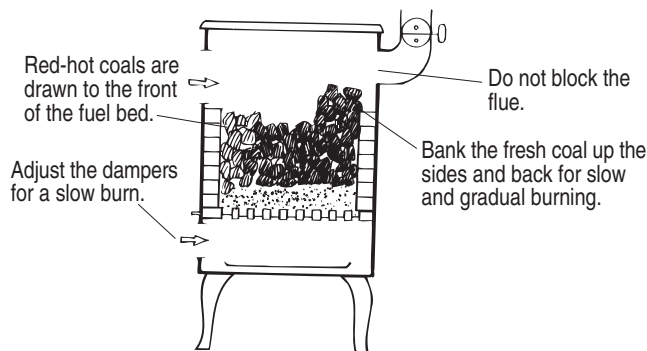

Figure 8–7. Banking the fire for a slow burn

Saving a Fire

If the fire has died down after being unattended, it may be necessary to ignite a thin layer of coal before adding a larger quantity. In some cases, it may be necessary to rekindle with wood before adding coal. This will eliminate the messy and time-consuming procedure of removing all the unburned fuel and starting from scratch. Open the ash door and stovepipe damper and close the fire-door damper to get a strong draft through the grate. Do not poke or shake down ashes at this time, as this will tend to cool the fire further. Start by adding small amounts of coal. After the fresh coal has ignited and there is a substantial bed of hot coals, the ashes can be shaken down and the dampers adjusted to a lower setting.

If the Fire Goes Out

Some stoves are equipped with dumper grates that expel the contents of the stove into the ash pan when desired. The unused coal can be screened out from the ash for reuse (figure 8–8). In most cases, however, it will be necessary to remove all the unburned fuel through the fire door without disturbing the ash layer. Then the fire must be restarted from scratch.

Burning Bituminous Coal

Bituminous coal burns differently from anthracite because of its higher volatile content. The first flames will be long, and generally orange or yellow. They will be accompanied by a considerable amount of smoke. As the gases burn off, the flames become shorter and may change color because of the types of

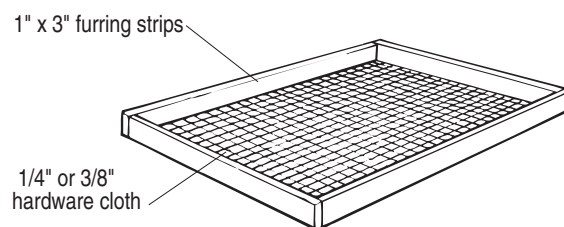

Figure 8–8. Screen for coal recovery from ashes

impurities present. The flame length also varies with the rate of burn, with the longer flames indicating a hotter fire.

Bituminous coal burning involves more maintenance than anthracite burning. Unless the coal is given a dustless treatment, there will be much more dust in handling. Certain measures, such as using an airtight stove with snug-fitting stovepipes and chimney connection, and creating as little agitation as possible when breaking up caked coal and removing ashes, will lessen the amount of dust that escapes into the house. The dust, which feels greasy, settles on everything, even vertical surfaces. It can be reduced, but it is difficult to eliminate. Also, more soot will collect on heating surfaces and in pipes, requiring more frequent cleaning.

Low-Volatile Bituminous Coal

Bituminous coal with less than 20% volatile content is generally fired with the conical method (figure 8–9). The first fire is built in the same manner as with anthracite. Once the fire is established, add coal to the center of the firebox to form a cone. More primary air flows around the perimeter when the fuel bed is shallow, creating a hot fire around the cone which drives off the volatiles and allows them to burn. After the volatiles are burned, the coke formed will burn more slowly, and you will get a long burn cycle.

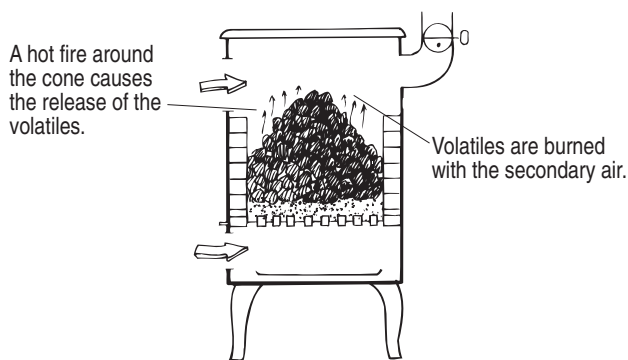

Figure 8–9. Firing low-volatile bituminous coal

Adjust the dampers about the same as for anthracite, except allow more secondary air to enter, and open the flue damper until the volatiles are burned.

Some coals cake and fuse as they burn, and this will eventually block the passage of oxygen through the coals below (figure 8–10). Before refueling, **gently** break up the caked bed of coals, being careful not to mix the coal, as this will increase the chance of clinker formation. When refueling, always leave some red coals exposed to allow the volatile matter released from the fresh coal to be burned. If the fresh coal covers the hot coals, the gases will be released, but the smothered fuel bed will not be able to ignite them.

If a flame does not start immediately after firing (because the live coals are not hot enough to ignite the gases), use paper or kindling to start a blaze. Failure to establish a flame after firing bituminous coal is likely to cause a minor explosion or “puffback.” To achieve maximum efficiency, leave the secondary damper open just enough to avoid puffbacks.

High-Volatile Bituminous Coal

High-volatile coal having more than 20% volatile content ignites easily and burns somewhat like wood with long, smoky flames.

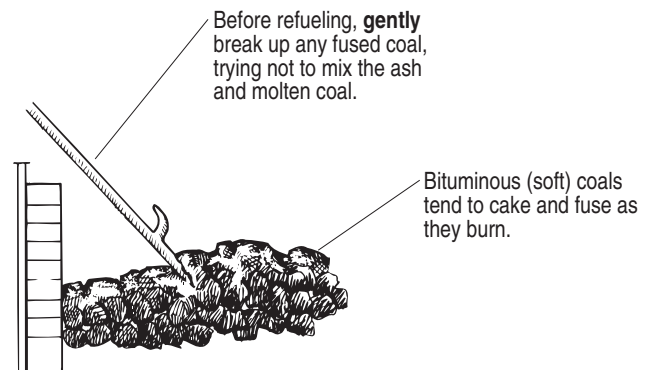

Figure 8–10. Soft coals tend to cake and fuse

One method for starting the fire is to pile fresh coal against the back or side of the firebox, allowing a little to cover the grate area. Paper and kindling are placed against the coal and ignited (figure 8–11). This ignites the coal pile from the outside and reduces the number of times that you have to add coal. When recharging, place coal where the kindling was, and heat from the burning coal will slowly penetrate the fresh coal, allowing for gradual distillation of the volatiles. It is important that any hot coals be removed from the empty half before refueling, leaving just a layer of

ash. Otherwise there will be partial burning and a lot of smoke.

The dampers are regulated the same as with other fuels, except that more secondary air is added to burn the volatiles coming off the top of the fire. For overnight operation, shake the fire and add coal. Allow the volatiles to burn off before closing the dampers in the fire door and flue. Close the primary air damper to the desired heat level.

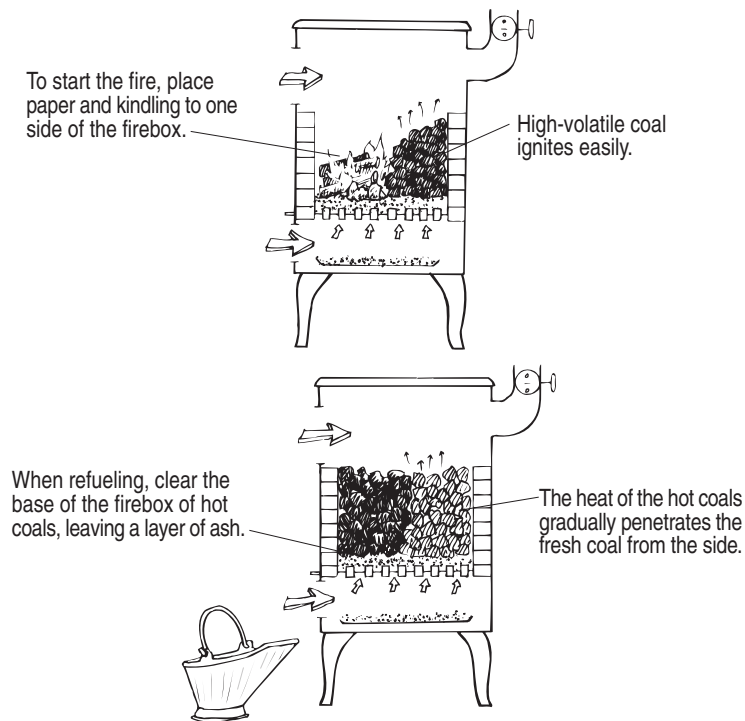

Figure 8–11. Firing high-volatile bituminous coal

Appendix A:

Cutting Firewood with a Chainsaw

You can cut wood with a handsaw, but a chainsaw can save considerable time and effort. Today's chainsaws are lightweight and have many features incorporated to make operation safer. Small saws with a 12- to 14-inch blade length are available for \$125–150. Larger saws with blades 16 inches or longer are several hundred dollars. Figure A-1 illustrates the parts of a chainsaw.

Unfortunately chainsaw accidents and injuries are quite common. **Inadvertent contact with the moving chain** is the leading cause of chainsaw accidents involving casual operators and helpers. Careless actions, such as reaching across or holding the wood near the moving chain, or loss of footing and subsequent loss of saw control, account for many accidents.

Kickback is the major unpredictable chainsaw hazard. Whenever the chain near the upper portion of the nose catches in the wood on an obstruction, it violently jerks the saw back and up. Kickback has caused many serious cuts to the chest and face. Low-kickback chain is available with depth gauges that keep the teeth from digging in too deeply. Some manufacturers also fit their saws with safety tip attachments.

In the last few years, most saw manufacturers have equipped their saws with chain breaks. Although this device does not prevent kickback, it does instantaneously stop the rotation of the chain if the saw is suddenly rotated backward.

In operation, watch for these kickback causes:

- Abrupt change of wood characteristics (i.e., green to dry, knots, etc.)
- Running the saw too slowly
- Buildup of damp sawdust

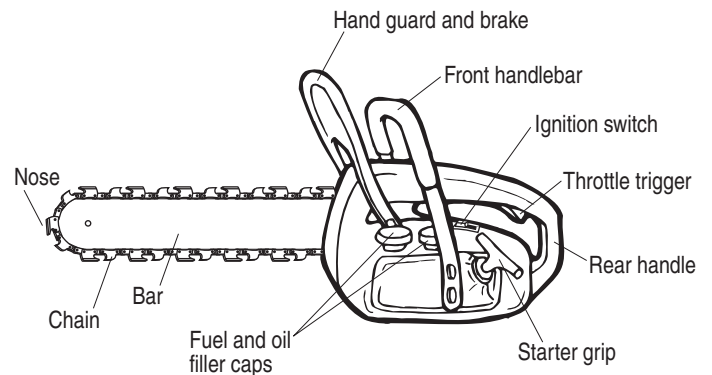

Figure A-1. Parts of a chainsaw

- A twig caught in the chain and jamming against the wood
- A branch or obstruction on the opposite side of the guide bar
- Twisting the saw so that the cutters grab the wood
- Sawing with the point of the guide bar (nose sawing)
- The closing of the kerf or slit cut by the saw

Felling and cutting timber is hard work, so good physical condition is important. An exhausted person can become a potential accident victim, so frequent rest breaks are essential.

Weather can create very serious hazards when cutting trees. The wind can come up suddenly or change direction unexpectedly, causing a tree to fall in the wrong direction. Avoid cutting trees on windy days. Instead, use these days for limbing (removing the limbs from the trunk) or bucking (cutting the trunk into desired lengths). Rain, snow, and ice may lead to unsafe footing. Rather than risk an injury, postpone work until conditions improve.

Equipment

Protect head, ears, feet, eyes, hands, arms, and legs (figure A–2) with:

- Trim-fitting trousers, shirts, and jackets to reduce the chance of becoming entangled in the saw. Purchase chainsaw chaps and socks that contain several layers of cut-resistant Kevlar® material.
- Light, nonslip Kevlar® gloves to protect hands from abrasion and wood cuts.
- Footwear with a good grip to prevent falls. Boots help to protect the lower legs. Steel-toe safety boots protect the toes.
- Safety goggles, face shield, or eyeglasses with safety lenses to prevent injury from flying wood chips or sticks.
- Protection against the 100-decibel or higher noise level of the saw. Limit operating time to 30 minutes per day unless good muffs or comfortable molded plugs are used for ear protection.
- A hard hat to prevent serious head injury from falling branches or limbs.
- A chainsaw sized to fit the task.
- Plastic or wood wedges and a hammer to prevent the chain from being pinched.

Operation

- If you are inexperienced in the operation of a chainsaw, obtain training from a saw shop or cooperative extension.
- Use the buddy system—don't work alone.
- Let the saw do the work. Don't force it through the cut. Learn to sharpen the chain properly and keep it sharp.
- Start the saw by holding it between your knees or placing it on the ground. Don't start it by holding the handle in one hand and pulling the starter cord with the other.
- Hold the saw firmly, with both hands in the proper position when cutting. Make sure the thumbs and fingers completely encircle the saw handle.

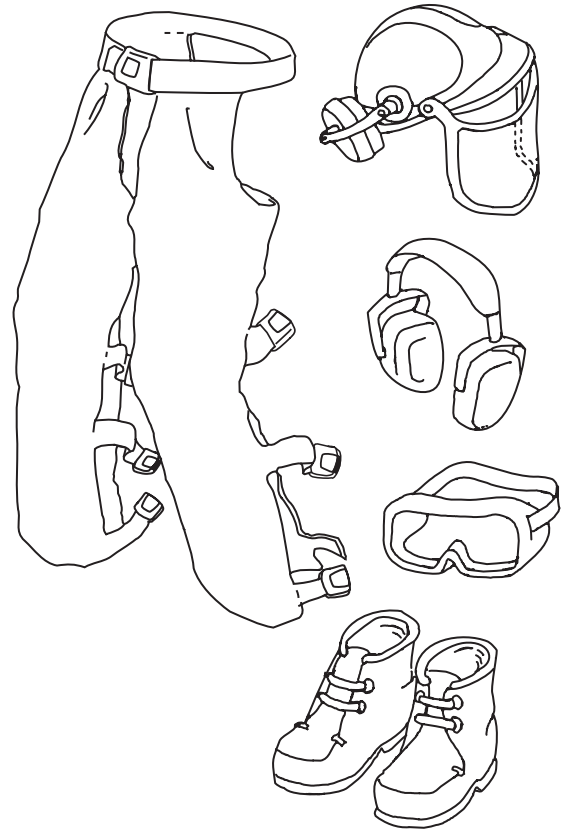

Figure A–2. Protect your body with the proper safety equipment when using a chainsaw

- Keep your elbows and knees slightly flexed for maximum control. Do not work with your arms extended.
- Operate the saw to the side of the body so that it will not swing into you if it kicks back or cuts through the wood unexpectedly.
- Never shift hand position or cross arms for easing strain or for better reach without first turning off the saw.
- Never cut over your head.
- Cut with the lower side of the saw as much as possible. This is the safest, least tiring position.
- Keep the guide bar in the middle of the cut so that the cutters on the opposite side will not bind. Do not twist the guide bar.
- Do not allow a running saw to contact the ground or metal; one such contact can dull the chain more than cutting dozens of trees.

If you are an inexperienced operator, make trial cuts to become accustomed to the cutting and handling characteristics of the saw. **Keep the chain sharp and properly adjusted** so it and the weight of the saw do the cutting. Do not apply extra pressure.

Felling

Consider the characteristics of each tree when determining the felling direction. A tree may lean or be unbalanced due to uneven top growth or breakage, even though the trunk does not lean. Large-diameter branches are good indicators of imbalance. For difficult or leaning trees, it is best to call an arborist or tree removal service.

Check for hollow or rotten trees, which may fall unpredictably. Be alert for loose branches or “widowmakers” in the tree. Special cutting methods are required to cut leaning trees. These trees may split at the stump and kill or seriously injure the chainsaw operator.

Prevailing wind direction affects tree growth and balance, while present wind conditions affect fall direction. The inexperienced operator should attempt to fell trees only under conditions that indicate a high degree of certainty as to which way the tree will fall. Plan an escape route before starting.

When felling a relatively straight-standing tree:

- Plan an escape route at a 45-degree angle away from the direction of the fall. Clear away brush. Keep spectators at least two-and-a-half tree lengths away.
- Make a notch on the side of the tree on which it is expected to fall. The first cut should be from the top at a 60- to 70-degree angle with the horizontal. This cut should be one-fifth to one-quarter of the diameter of the tree. The second cut should be made at a 30- to 40-degree angle from below the horizontal to meet the first cut. This forms a 90-degree notch, which allows the tree to hit the ground before the notch closes.

If the two notch cuts do not meet, recut so they do. Otherwise the tree may split or jump back when cut (figure A-3).

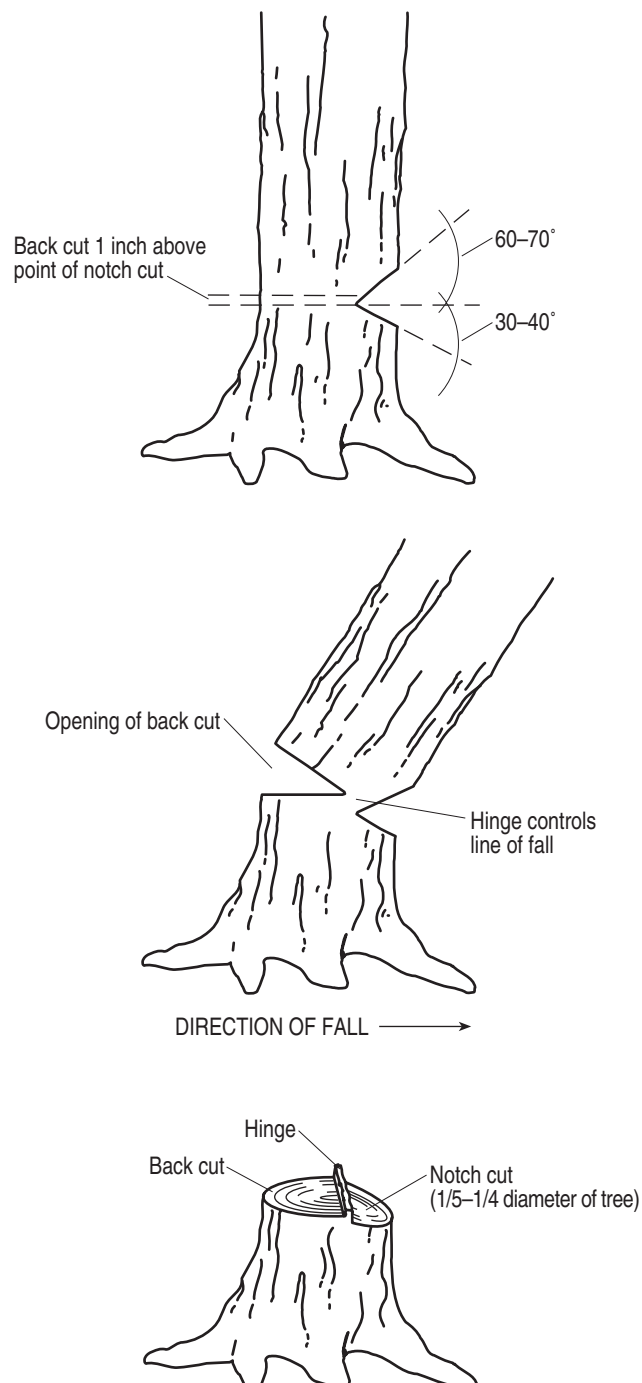

Figure A-3. Felling a tree

-
- Make the felling or back cut about 1 inch higher than the center of the notch. The felling cut should be kept parallel with the notch cut. Do not cut all the way through. Cut it so that at least 1 inch of wood fibers are left to act as a hinge, keeping the tree from twisting and falling in the wrong direction.
 - Keep the guide bar in the middle of the cut. Don't twist the guide bar in the groove. Guide the saw into the tree—don't force it. The rate of feed will depend on the size and type of timber.
 - In larger trees, place a plastic or wood wedge into the groove to keep it open and keep the saw from pinching.
 - Remove the saw from the cut before the tree falls. The tree will begin to fall as the felling cut approaches the hinge fibers. Move to a safe spot away from the stump and **look up** for falling branches.
 - Do not cut through the hinge fibers. The tree could fall in any direction—maybe in the direction in which you are retreating.

A binding saw and closing kerf indicate an error in judgment. At the first such indication, remove the saw. If the saw cannot be removed, do not struggle with it. Shut off the engine, clear the area, and plan a course of action using wedges to remove the saw.

If you are tiring and still have a fair amount to cut before the tree will fall, remove the saw, shut it off, and rest until you are able to proceed with confidence. Also, **check the fuel supply** before starting a cut that will require a long running period. When you add fuel, always add chain lubricating oil.

A well-balanced tree may have to be wedged to direct a fall. Use only wooden, aluminum, or plastic wedges—steel or iron wedges may damage the chain. Sometimes two wedges can be cross-stacked to ensure a forward fall of the tree. Strike squarely with a sledge or mallet with a face broader than the wedge.

Careless or excessive blows may cause the wedge to pop out, swinging the tree backward. **Do not** use an ax head as a wedge or driver because it may break.

The manipulation of fall control comes with experience. Approach complex falls with extreme caution. Above all, do not neglect wind effects. Always keep the felling direction as simple as possible, and avoid working on windy days.

Use a tractor or winch to pull away a tree that hangs up in another tree during felling. A small tree can sometimes be rolled with a lever or peavey to dislodge it. **Do not** cut the standing tree or climb either tree.

Limbing

Many chainsaw accidents occur during the limbing process. Using a lightweight saw with a short bar makes holding and maneuvering easier. The lower horsepower helps the operator control the saw in kickback situations. Limbing progresses much more rapidly when the saw is sized to the task.

Cut limbs on the top side of the trunk before removing those resting on the ground. Remove lesser branches as the work progresses up the trunk, as they impair vision, present obstacles, and may cause kickback due to twigs lodging in the blade. Use extra caution when cutting small-diameter limbs, as the slender material may catch in the saw and be whipped toward you. Cut branches to desired length before they are cut from the trunk.

Saw limbs on the opposite side of the trunk from where you stand, using the trunk as a barrier. If it is necessary to work with the saw on the same side, keep the saw to the side of your body so that it will not swing into your legs or head. Avoid reaching with the saw, and always maintain good footing and balance.

Cut the branches resting on the ground to improve working conditions underfoot as the work progresses.

The tree may sag or roll as each branch is cut. **Key branches stabilizing the tree should be left until last.** A closing kerf signals the probability of kickback. Keep the engine speed up—a slow-moving saw chain is more likely to lock than one cutting freely at a higher speed.

Final supporting branches might be saved to facilitate bucking. The trunk, however, should be stable and not vulnerable to roll during bucking.

Bucking

Bucking is the process of cutting the tree into stove or cordwood lengths. Hazards of bucking are unexpected roll of logs and kickback. Be sure of your footing when working on hillsides, and always work on the uphill side of the log. Raise and check the trunk or roll the log to complete the cut. Place pieces of wood under the main stem before cutting the branches so that when it falls, it will be held up off the ground. Do not saw into the ground. Use levers, sturdy poles, or bars as much as possible. Do all manual lifting with proper lifting techniques to avoid back strain or injury (figure A-4).

It is usually easier to handle wood from small trees in 4-foot lengths and stack it to dry. Then cut the pieces on a sawbuck or pallet rack before use in the fall.

Splitting Wood

By Hand

Tools used to split firewood logs include a splitting ax, an 8-pound sledge, a splitting maul, and wedges. The axes and wedges should be kept reasonably sharp, so keep a file and a stone handy.

It takes practice to learn to split wood safely and efficiently. Learn to read the flow of the grain, and work with this flow rather than against it to make wood-splitting more enjoyable. Grain patterns differ between tree species; a straight-grained ash will

When the log is supported on one end, cut one-third of the diameter from the underside. The final cut is made from the top.

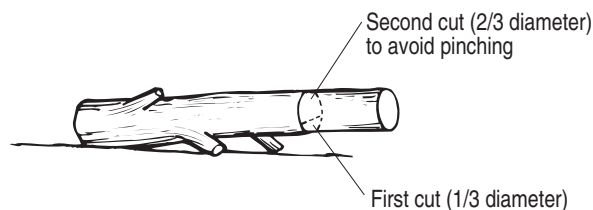

When the log is supported on both ends, cut one-third of the diameter from the top. The final cut is made from the underside.

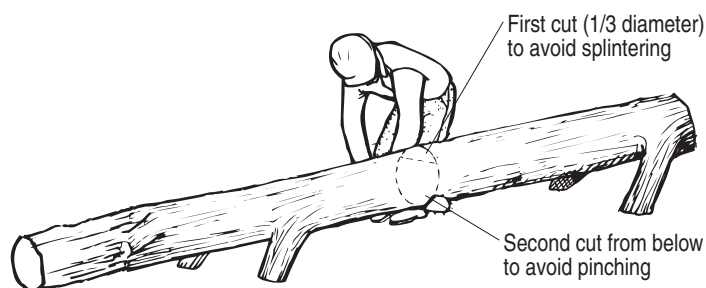

Figure A-4. Cutting the tree into desired lengths

always split easier than an elm with its interlocking and interweaving wood fibers. The grain also varies within a tree and will prove to be most difficult around branches and knots.

Never split stove-length wood directly on the ground, as this is a good way to strike a rock or your foot. Place the piece to be split on a chopping block, which can be either a larger log or a stump about 20 inches high. Flex your knees when you swing so that the angle between the log and your ax is 90 degrees. If it does not split, drive a wedge in at the center; two wedges placed halfway between the center and the edge may be needed with larger or stubborn blocks. Wedges carefully placed can also be used to free a buried ax or maul.

When the log has a branch stub or visible knot in it, locate the split line so that the crack will run through the center of the knot or stub. Hidden knots can sometimes be detected by observing a curve in the otherwise straight grain. A crotch log is difficult to split—either saw the legs apart, or stand the log on its legs and drive a wedge in line with the legs' centers.

With a Power Wood Splitter

The hydraulic wood splitter can save considerable energy and time. Several different models are available including horizontal and vertical operation, independent engine, and tractor-mounted. Splitting force, measured in tons, is determined by the diameter of the cylinder and the hydraulic pressure available from the pump. Average production is about one-half to one cord per hour for homeowner models and up to three cords per hour for heavy-duty commercial models.

Wood splitters are constructed using a steel “I” or rectangular beam with a hydraulic cylinder that is mounted so that it pushes the log through a steel wedge (figure A-5). A two-way valve controls the movement of the piston in the cylinder. Some ma-

chines have an automatic cycle feature that returns the push block to the starting position.

Power for a splitter is from an independent air-cooled engine of 5–20 horsepower. This powers a hydraulic pump that creates oil pressure to move the piston in the cylinder. Units are available that will utilize the power take-off or hydraulic system on a small tractor, usually at least 12 horsepower.

Options include a hydraulic log lifter, log cradle, four- or six-way wedges, transport wheels, and fast cycle time. Standard wood splitters will normally handle firewood up to 24 inches long, but some models are available that will split cord wood 4 feet long.

Safety is important when working with a wood splitter. Large chunks of green wood are very heavy, and care should be taken when lifting them. Hand, eye, and leg protection should also be used to prevent injuries.

For the average homeowner that prepares three to six cords per year, it may be less expensive to rent a splitter for a day. Units are available from many rental outlets.

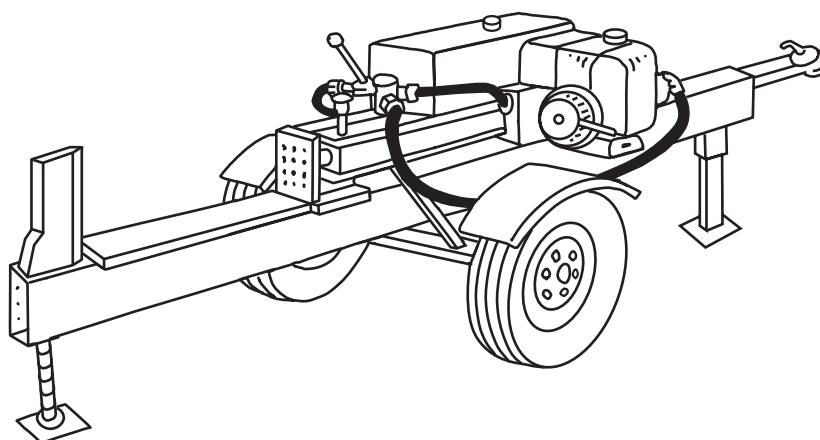

Figure A-5. Purchase or rent a power wood splitter to speed wood preparation

References

- Bartok, John W., Jr. *Heating with Coal*. Garden Way Publishing Co., Charlotte, VT 05445. 1980.
- Bartok, John W., Jr. *Solid Fuel Furnaces and Boilers*. Garden Way Publishing Co., Charlotte, VT 05445. 220 pp. 1982.
- A Guide to Residential Wood Heating*. Natural Resources Canada. 2002.
- Hayden, A. C. S. and R. W. Bratten. *Wood Stove Operation and Advanced Design to Reduce Emissions of Incomplete Combustion Products*. Canadian Combustion Research Laboratory, CANMET, 555 Booth Street, Ottawa, Canada K1A 0G1. March 1985.
- How to Burn Wood Right*. CONEG. 1992.
- International Building Code—2000*. Southern Building Code Congress International, Inc., Birmingham, AL. 2000.
- Reeb, James E. *Open Face Tree Felling Method: Improving Production, Safety and Quality*. Cooperative Extension Service, University of Kentucky. Publication FOR-60. 2 pp.
- Shelton, Jay W. *Wood Heat Safety*. Garden Way Publishing Co., Charlotte, VT 05445. 165 pp. 1979.
- Standard for Chimneys, Fireplaces, Vents and Solid Fuel Burning Appliances*. ANSI/NFPA 211. National Fire Protection Association, Batterypark, Quincy, MA 02269. 1994.
- Van Ryn, Debbie M. and James P. Lassoie. *Managing Small Woodlands for Firewood*. Cornell Cooperative Extension Information Bulletin 208. 1998.
- The Woodburner's Companion: Practical Ways of Heating with Wood*. Alan C. Hood & Co., Inc., Chambersburg, PA 17201. 2000.

About NRAES

NRAES, the Natural Resource, Agriculture, and Engineering Service, is a not-for-profit program dedicated to assisting land grant university faculty and others in increasing the public availability of research- and experience-based knowledge. NRAES is sponsored by fourteen land grant universities in the eastern United States (see map below). We receive administrative support from Cornell University, the host university.

When you buy books from NRAES, you are helping to improve the accessibility of land grant university knowledge. While 15% of NRAES' annual income is provided by member universities, the funds to publish new books and coordinate new conferences come from our customers through book sales, conference registrations, and occasional project-specific grants.

NRAES publishes practical books of interest to fruit and vegetable growers, landscapers, dairy and livestock producers, natural resource managers, soil and water conservation district staff, consumers, landowners, and professionals interested in agricultural waste management and composting. NRAES books are used in cooperative extension programs, in college courses, as management guides, and for self-directed learning.

NRAES publishes two types of books: peer-reviewed books and conference proceedings. Our peer-reviewed books are evaluated prior to publication for technical accuracy and usefulness to the intended audience. The reviewers may include university faculty, extension educators, potential users, and interested persons from government and agribusiness. Conference proceedings are not peer-reviewed. However, the authors of papers presented at NRAES-sponsored conferences are chosen for their recognized expertise. NRAES also distributes some videos related to waste management and fruit and vegetable production.

NRAES was started in 1974 and was originally known as the Northeast Regional Agricultural Engineering Service. In 1987, with encouragement from member university extension directors, NRAES began offering its services to faculty from all disciplines at member universities. In 1998, Virginia Polytechnic Institute and State University joined the original thirteen member universities. Our name was changed in 1998 to reflect the expansion of NRAES beyond the Northeast and the broadening scope of our books and conferences. Contact us for more information or a free book catalog.

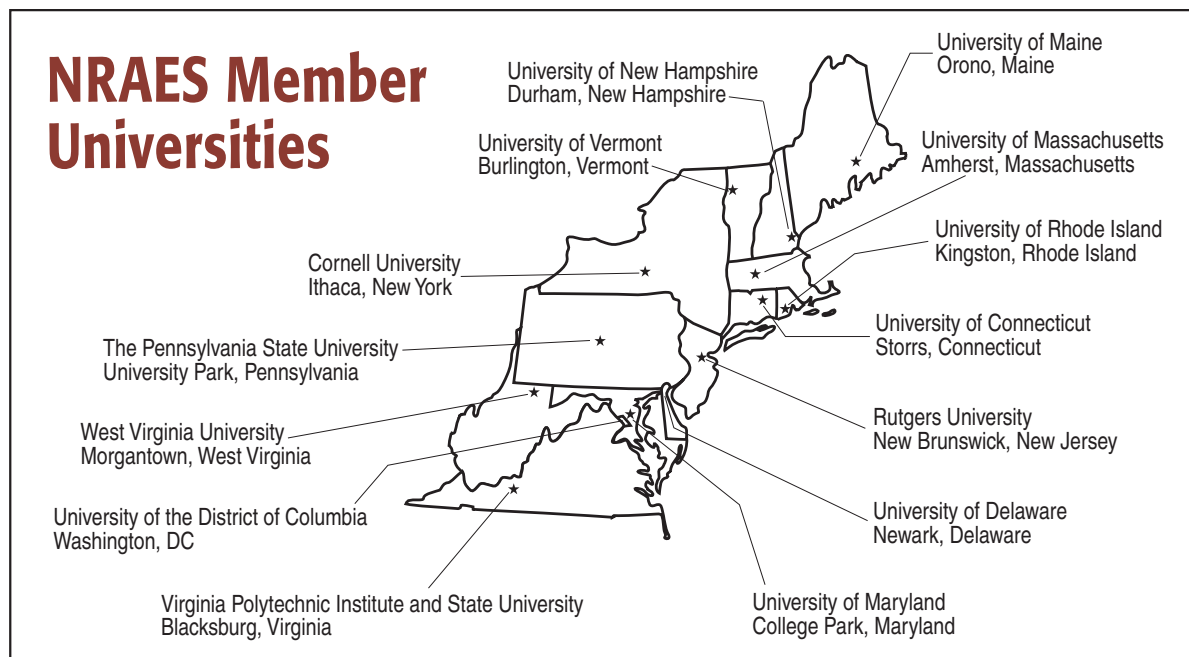

NRAES
Cooperative Extension
PO Box 4557
Ithaca, New York 14852-4557

Phone: (607) 255-7654
Fax: (607) 254-8770
E-mail: NRAES@CORNELL.EDU
Web site: WWW.NRAES.ORG

Marty Sailus, NRAES Director
Jeffrey S. Popow, NRAES Managing Editor