

CORNELL

JANUARY | FEBRUARY 2018 \$6

Owned and Published by the Cornell Alumni Association

ALUMNI MAGAZINE

E Sagugae lacus aqua
undis ueneta
Surgit nostra Alma Mater
nobilis, pulchra.

Tolle cantum! Laudes eius
Sursum ascendant!
Aue nostra Alma Mater!
Vigeat Cornell!

Active Voice

The Hill is alive with the sound of Latin

PLUS:

The evolution of CU's libraries

TV journalist S.E. Cupp '00

Bobsledding alumna aims for
second Olympic medal



Seeking 43 great leaders.



The Harvard Advanced Leadership Initiative offers a calendar year of rigorous education and reflection for highly accomplished leaders in business, government, law, medicine, and other sectors who are transitioning from their primary careers to their next years of service. Led by award-winning faculty members from across Harvard, the program aims to deploy a new leadership force tackling the world's most challenging social and environmental problems.

HARVARD
ADVANCED LEADERSHIP INITIATIVE



be inspired at advancedleadership.harvard.edu

+1-617-496-5479



48



16



13

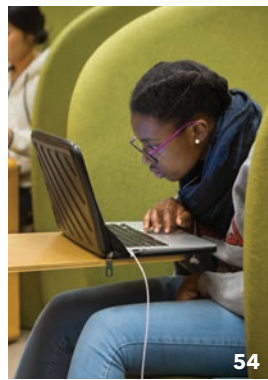

54

40 Living Language

Last fall, the classics department began offering a course whose title would long have been considered an oxymoron: Conversational Latin. It's taught by Daniel Gallagher, a former Catholic priest and Vatican translator who aims to revolutionize instruction in Latin as an active language. "This idea of learning Latin through the spoken method is not a gimmick," notes President Emeritus Hunter Rawlings, who helped recruit Gallagher to the Hill. "This is to help you learn it well, so that when you read Cicero or Virgil or whomever, you understand it better."

48 An 'Unfiltered' Voice

A TV veteran, conservative commentator S.E. Cupp '00 now has her own program on HLN, CNN's sister network. While Cupp has built a reputation as someone who isn't afraid to speak her mind, she aims for a level of civility on her show, which covers a mix of politics, human interest stories, and current events. "We are passionate and emotional about everything we talk about, but the audience can hear us articulate our points," she says. "No one is shouted off."

54 By the Books

Just as campus libraries have evolved from paper to digital, so have the ways in which students use them. While the online revolution could have made these brick-and-mortar facilities as obsolete as index cards, the opposite has happened: at Cornell, the libraries are as essential as ever, and arguably even more lively. Long seen as vaunted spaces for quiet contemplation and scholarship, they've taken on a broader role, becoming vibrant hubs for socializing, collaborating, and more.

CURRENTS

- 13 SPEED RACER**
Olympic bobsledder
Jamie Greubel Poser '06
- 16 FEAST YOUR EYES**
Visual effects guru
- 20 FAST FOODIE**
Daniel Schwartz '01 is
CEO of Burger King
- 24 LETTER PERFECT**
A classic keyboard reborn
- 28 ON THE BALL**
Senior juggling champ
- 30 MOBILE HOME**
Student's four-wheeled abode

DEPARTMENTS

- 5 CORRESPONDENCE**
- 6 FROM MARTHA POLLACK**
- 8 FROM THE HILL**
- 34 AUTHORS**
- 36 SPORTS**
- 67 CLASS NOTES**
- 93 ALUMNI DEATHS**
- 96 CORNELLIANA**
MLK's visits to Cornell



96

- 63 EZRA MAGAZINE EXTRA**
Weill Cornell Medicine Dean
Augustine Choi on mentorship,
global outreach, and more.

A special insert produced by University Relations and the Division of Alumni Affairs and Development

ON THE COVER: PROF Es sOR DaNIEl G al I aGHER's I aTIN TRaNsI aTION Of THE fIRsT VERsE aND CHORus Of THE al ma maTER; sCROl I , iNCHENDIO/ isTOCK; il I umiNaTED E, aRTYzaN/sHuTTERS TOCK

Romance

of the Douro Wine Region

OCTOBER 11 - 22, 2018

No Single
Supplement
for Solo
Travelers!

This tour features three nights in Lisbon, Portugal, at the first-class Sofitel Lisbon Liberdade, and seven nights aboard the first-class MS *Gil Eanes*. (All cabins provide outside river views.)

- Delve into the history and culture of Lisbon's vibrant capital city
- Explore the town of Óbidos, a showcase of varied architectural styles
- Marvel at the gilded library at the University of Coimbra
- Visit Solar de Mateus, an 18th-century baroque palace in Vila Real
- Travel through Douro Valley, and enjoy a port wine tasting
- Uncover the sites of pretty Lamego



We will be joined on this tour by alumni from peer institutions. Cornell's small group will enjoy all excursions together, be feted with a reception just for us, and enjoy unique-to-Cornell moments that make traveling with us so special. (Offered in partnership with AHI.)

Call 800-323-7373 for details or check out our website to see the brochure for this and other 2018 tours!

Now Your Family & Friends Can Shop for YOU!

Anytime. Everywhere. 24/7/365

www.MyAmericanCrafts.com

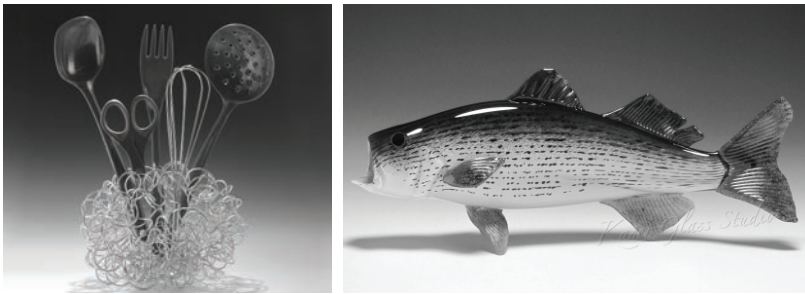

Tell Them, "I'd Like Anything From..."

american crafts
by robbie dein

158 Ithaca Commons
(607) 277-2846 ♦ info@ACRD.biz

An Ithaca Gift Giving Tradition Since 1972

Sharing the Art & Soul of America's Finest Artisans
Pottery ♦ Art Glass ♦ Jewelry ♦ Woodwork ♦ Fiber

CORNELL

ALUMNI MAGAZINE

Cornell Alumni Magazine is owned and published by the Cornell Alumni Association under the direction of its Cornell Alumni Magazine Committee. It is editorially independent of Cornell University.

Editor & Publisher

Jenny Barnett (jeb375@cornell.edu)

Senior Editor

Beth Saulnier (ess8@cornell.edu)

Class Notes Editor & Assistant Editor

Alexandra Bond '12 (abb83@cornell.edu)

Assistant Editor/Media

Shelley Stuart '91 (sls1@cornell.edu)

Editorial Assistants

Chris Furst, '84-88 Grad
Tanis Furst

Contributing Editors

Brad Herzog '90
Sharon Tregaskis '95

Art Director

Jennifer Kloiber Infante (jlk29@cornell.edu)

Assistant Art Director

Lisa Banlaki Frank (eaf32@cornell.edu)

Circulation/Business Manager

Adele Durham Robinette (adr4@cornell.edu)

Accounting Manager

Barbara Bennett (bkb5@cornell.edu)

Editorial Intern

Kayleigh Rubin '19

**Advertising: Display, Classified
Cornellians in Business**

Sandra Busby (slb44@cornell.edu)
(800) 724-8458 or (607) 272-8530, ext. 23

Ivy League Magazine Network

www.ivymags.com

Heather Wedlake, Director of Operations
heatherwedlake@ivymags.com
(617) 319-0995

Editorial & Business Office

401 East State Street, Suite 301
Ithaca, NY 14850
(607) 272-8530; FAX (607) 272-8532

Cornell Alumni Magazine Committee

Betty Wong Ortiz '94, Chair
Rob Rosenberg '88, Vice Chair
Jim Mazza '88, Secretary/Treasurer
Andy Guess '05
Karen Kovacs '86
Tom Mahar '04
Farhad Manjoo '00
Abhijit Pal '02
David Steward '79

For the Cornell Association of Class Offices:

Paul Cashman '73, President
CACO Alternate: Rosanna Romanelli Frank '61

Cornell Alumni Association Board

Betty Wong Ortiz '94, Chair
Rob Rosenberg '88, Vice Chair
Jim Mazza '88, Secretary

Issued bimonthly. Single copy price: \$6. Yearly subscriptions: \$36, United States and possessions; \$51, international. Printed by The Lane Press, South Burlington, VT. Copyright © 2018, Cornell Alumni Magazine. Rights for republication of all matter are reserved. Printed in U.S.A.

Send address changes to Cornell Alumni Magazine,
c/o Public Affairs Records, 130 East Seneca St.,
Suite 400, Ithaca, NY 14850-4353.



Bear Witness

I enjoyed the article about Touchdown the Big Red Bear in the recent CAM (November/December 2017). Although the identities of many who played the bear remain secret, I can reveal at least one.

In mid-February 1967, Cornell and Princeton were tied for the Ivy League basketball lead, Cornell having handed Princeton their only League loss. Their second game, to be played in Princeton on Saturday, February 25, became a must-win for both teams. My sophomore roommate and I drove to Philadelphia the day before for a game against Penn, which Cornell won handily. We planned to go to Princeton the next day, even though there were no tickets to be had for the game, which was to be played in the tight quarters of Dillon Gym.

In the 1960s and Seventies those who played the Big Red Bear weren't as well organized as they are today, and the mascot didn't necessarily travel to all the away games. Somehow, I discovered this fact. Before leaving Philadelphia Saturday morning, we located a costume shop and rented a beautiful "Big Red Bear."

Upon arriving in Princeton I donned my disguise, walked directly in the team entrance, and spent the game sweating on the sidelines, cheering for Cornell, irritating the tiger, and taking insults from Princeton fans. I'm not sure I had a very good view of the game through the costume, but I definitely had the best seat.

Unfortunately, Cornell lost the game and finished second in the Ivy League, but our trip to Princeton was a great memory. I wish I had some pictures of this escapade; if you know of anyone who might, I'd love to contact them.

PETER FRIED '69
MADISON, NJ

Getting Into The Spirit

I enjoyed reading the CAM article about the origins of Zinck's Night ("Happy Hour," September/October 2017), now in over 100 bars around the world. The article left out a key chapter of the story, though: how did it go from a weekly campus event to an annual event at local alumni clubs?

The Class of 1975 originated the idea to deal with a problem that younger graduates faced in the late 1970s with local alumni clubs. My first local alumni chapter meeting in Houston after graduation felt like I had wandered onto a trans-Atlantic cruise ship, because the average age was over sixty-five. When I compared notes with classmates, it was the same everywhere outside of New York City, and few were interested in going back to their local alumni chapters for meetings. As the newly elected alumni class president after graduation, I was trying to figure out how we could re-invigorate local clubs with younger alums and keep everyone's heartstrings tied to Cornell.

We knew that young Cornellians liked to drink, so why not host parties across the country in popular bars? We set up eight parties simultaneously in May 1977 and cohosted them with the classes of 1974 and 1976 (Ithaca: Craig Esposito '74; NYC: Lou Walcer '74; Boston: Neal Haber '75; Philadelphia: John Foote '74; San Francisco: Sandy Ward '76; Washington, D.C.: Ann Spudis '76; Chicago: Leon Rafner '74, MEN '75; I organized the Cleveland event). After the first year's success, we adopted the name Spirit of Zinck's, moved it to the fall of the following year, and expanded the number of locations and classes invited.

The lesson is: never underestimate how much Cornellians like to party together!

DAVE PRITCHARD '75
SAN MATEO, CA

A Big Game

In the September/October 2017 issue, we asked you to share your favorite Cornell sports moments.

The 1962 varsity football game between Cornell and Princeton, which Cornell won 35-34, was the most exciting football game I have even seen—college or professional. I will never forget the miraculous running and passing exploits of Gary Wood '64. It is unfortunate that the films to this game have apparently been lost, but all the Cornellians present will never forget it.

SEYMOUR R. ROSEN '64, BS '65
TALLAHASSEE, FL

SPEAK UP! CAM encourages letters and comments from readers on the magazine's content. They may be edited for length, clarity, and civility. We are not able to publish and respond to all correspondence received. Send to: Editor, Cornell Alumni Magazine, 401 East State Street, Suite 301, Ithaca, NY 14850; jeb375@cornell.edu; cornellalumnimagazine.com.

CONNECT AND SHARE
FACEBOOK Cornell Alumni Magazine
TWITTER @CUAlumniMag

Sicily, the 10,000 square mile museum



Discover the ancient Greek, Roman, Medieval, Renaissance, Baroque and nineteenth-century sites of Sicily on this carefully-paced 13-day tour, brought to you by the leading specialist in cultural vacations.

We stay in the vibrant cities of Palermo, Taormina and Syracuse, where we enjoy exceptional hotels, food and local hospitality. Our tours are accompanied throughout by an archaeologist or art historian, whose expert knowledge brings insight into this diverse island.

Request a brochure:
1-800-988-6168
usa@martinrandall.com
martinrandall.com

ATOL 3622 | ABTA Y6050 | AITO 5085



MARTIN
RANDALL
TRAVEL

LEADING EXPERTS IN CULTURAL TOURS

Cornell and China: A Historic Partnership



MEETING OF THE MINDS: Pollack (center left, behind banner) with members of the Cornell China Advisory Board

With China now the world's second-largest economy and a major player on the global stage, Cornell is building upon and extending its long-standing engagement with the nation and its people in order to contribute to the advancement of bilateral relations. We are prepared to create long-term partnerships to increase our presence in China and raise the University's profile there.

Cornell offered its first course in Chinese language in 1879, and we educated many of China's future leaders in the late nineteenth and early twentieth century. Cornell's collaborative research with Chinese institutions, which began in the 1920s, initially focused on increasing yields of important food crops, in the process training a generation of Chinese plant breeders. Today, Cornell partners with peer institutions throughout China on teaching and research projects—from agriculture and food science to engineering and sustainability to business management and economics to fiber science and apparel design. The Cornell Institute for China Economic Research, for example, draws together sixteen faculty members from seven departments across four colleges for research, educational opportunities, and engagement with policymakers to bring Cornell to China and China to Cornell.

Our undergraduate China and Asia-Pacific Studies program, founded a dozen years ago through the vision of Michael Zak '75, includes four years of intensive instruction in Chinese language plus semester-long internships in Washington, D.C., and Beijing. Cornell Abroad administers semester and academic year study programs in China for Cornell students, and the College of Agriculture and Life Sciences offers bachelor of science programs whereby Chinese students complete two years of study at a Chinese partner university, followed by

two years at CALS. Students from China now make up the largest segment of our international student population by far, and the alumni community in China, some 1,450 strong, is our largest outside the U.S. and Canada.

We are now poised to take these initiatives to the next level by establishing a Cornell China Center in Beijing. It will have three basic purposes: to build capacity for the delivery of educational content and to spark innovative and collaborative research projects that span and benefit both countries; to be a vibrant gathering place for Cornell faculty, alumni, students, and prospec-

tive students and for Chinese scholars, friends, collaborators, and partners; and to raise the University's profile in China, giving us a presence that reflects our distinguished reputation and helping cement a permanent bond between Cornell and the people of China. A faculty committee is guiding academic aspects of this initiative, and Cornell staff in Ithaca, New York City, and Beijing are already working on implementation from a temporary space in Beijing's Central Business District.

Additionally, we are very fortunate to have the advice and support of a distinguished Cornell China Advisory Board chaired by Gang Yu, MS '86, co-founder and chairman of New Peak Group. I had the privilege of participating in the board's

Our expanding efforts in China illustrate a broad commitment to international activities that are both a part of our past and critical to our future.

October 2017 meeting at Cornell Tech on Roosevelt Island. Its members are some of our most distinguished alumni and friends in China, and I am greatly encouraged by their understanding of the role that the University can play in this part of the world and by their willingness to support our efforts.

From the very beginning, Cornell has been a global university. Our expanding efforts in China illustrate a broad commitment to international activities that are both a part of our past and critical to our future. I am looking forward to meeting many more alumni living abroad with visits to India, Korea, and Hong Kong on my schedule for the spring 2018 semester. ■

Martha E. Pollack
president@cornell.edu

You **DON'T**
have to be into

PREVENTING MUSCULOSKELETAL DAMAGE

to give
to Cornell.

There's something for **you** at Cornell.

Make your gift today.
giving.cornell.edu/give

Cornell professor Huiju Park researches firefighters' movements
to design better-fitting protective gear, preventing injuries.

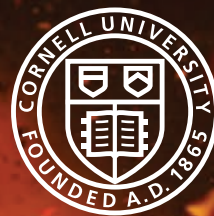

Photo by DigitalStorm/Stock.

From the Hill

Ezra's Tunnel Through Gorge to Close



DARK PASSAGE: Ezra's Tunnel in the nineteenth century and (above right) today



Ithaca's Common Council has voted to fence off Ezra's Tunnel. Blasted through the side of Fall Creek Gorge by the University's founder in the early 1830s to obtain water to power nearby mills, the tunnel has been the subject of debate in recent years due to safety concerns: it offers access not only to the gorge but to an illegal swimming hole where two Cornellians drowned in recent years: Winston Perez Ventura '22 last August and Kendrick Castro '11 in spring 2011, the day after he graduated. While some have argued in favor of closing off the tunnel, others have decried the move as overly paternalistic and draconian, advocating warning signs instead. "Unfettered access to the natural world is one of the perks of living in Ithaca," Ithaca Mayor Svante Myrick '09 told the *New York Times* in early December. "But this is an attractive nuisance—a danger that is too cleverly disguised."

Cornell Cinema Loses Funding from Student Activity Fee

The Student Assembly (SA) has voted to stop funding Cornell Cinema, reducing to zero its allocation from the activity fee paid by all undergrads, after having supported it for more than two decades. For the past two academic years, the cinema has received \$10.90 of the approximately \$240 annual fee, with other portions going to entities like the Slope Day programming board, Convocation, and the Women's Resource Center. The cinema, which had previously faced SA demands to cut costs, had requested an allocation of \$8.50 for 2018–20. The funding that the cinema received in 2016–18, totaling about \$150,000 a year, had represented 30 percent of its budget; the effect of the defunding on its future is unclear. The SA debate, which played out during the fall semester, sparked a passionate reaction from the cinema's student and alumni fans, including a change.org petition decrying the defunding that garnered some 4,000 signatures. On a website explaining its decision, the SA called the cinema "unsustainable," noting that over the past few years, it "has failed to comply with formal and informal requests of the Assembly to improve its efficiency."

Tech Café Offers CU Ice Cream

New York City-based alumni finally have a place to satisfy their craving for Cornell Dairy ice cream. The café on the new Tech campus now offers more than fifteen flavors including Clock Tower Pumpkin, Ezra's Morning Cup, Cornelia's Dark Secret, and Martha's Bits & Bytes.



Cornellian Quintet on Forbes Power List

Five alumnae are among the honorees on *Forbes's* 2017 list of the world's 100 most powerful women. They are Tsai Ing-wen, LLM '80 (left), Taiwan's first female president (number fifteen); Supreme Court Justice Ruth Bader Ginsburg '54 (twenty-four); Lubna Olayan '77, CEO of Olayan Financing (fifty-nine); and venture capitalists Mary Meeker, MBA '86 (eighty-four), and Jenny Lee '94, MEng '95 (ninety-four).

PHOTOS: TUNNEL (VINTAGE), RMC, (OTHER), PROVIDED; ICE CREAM, JASON KOSKI (UREL); TSAI, JASON KOSKI (UREL)



LOOKING UP(SON): The \$74.5 million gut renovation of Upson Hall—part of a \$300 million, decade-long overhaul of the Engineering Quad—has been completed. The design team on the project included two architecture alumni, Robert Goodwin, BArch '84, and David Lewis, MA '92. The 1956 building, home to mechanical and aerospace engineering, had originally been designed by two Cornellians, Lawrence Perkins '30, BArch '31, and Philip Will '28, BArch '30.

'It's kind of like having a depth of knowledge on NASCAR and you've gone to a lot of races, but nothing in your experience equips you for getting behind the wheel and driving at 200 miles per hour.'

— Plant pathology researcher David Gadoury, on training New York hop growers to supply the craft beer industry



MUSEUM PIECE

What item belonging to "Science Guy" Bill Nye '77 is on display at the Smithsonian's National Museum of American History until July 4, 2018?

- a) Lab coat
- b) Bow tie
- c) Emmy award
- d) All of the above

[ANSWER: D]

R + D



A Cornell-led team has found that fungicides stunt the growth of bee colonies and can increase the insects' susceptibility to a fatal gut infection. It was previously thought that factors such as insecticides or changes in land use were largely responsible for the bee population decline.

After analyzing nearly 9,000 national surveys, policy analysis and management PhD candidate Erin McCauley found that people who have disabilities are more likely to be arrested than those who don't. Black men with disabilities were at particularly high risk, with 55 percent arrested by age twenty-eight.

Scientists at the Boyce Thompson Institute have sequenced the genomes of two pumpkin species—*Cucurbita maxima* and *Cucurbita moschata*—to better understand their contrasting traits. The work could facilitate breeding of more nutritious pumpkins.



Researchers at the Medical and Vet colleges have answered the long-standing question as to why testicular cancer responds so well to chemotherapy, even after it has metastasized. They found that testicular cancer stem cells are especially sensitive to chemo—potentially providing insights into treating other forms of the disease.

In the first study of its kind, sociology professor Steven Alvarado found that people who spend any part of their childhood living in disadvantaged neighborhoods are 75 percent more likely to experience unemployment as adults.



Tata Gift Spurs Naming of Tech Campus Building

The Bridge—the dramatic glass building that houses companies collaborating with faculty and students on the Tech campus—has been renamed the Tata Innovation Center. Ratan Tata '59, BArch '62, a Cornell trustee and benefactor, is chairman emeritus of a group of family companies that are among India's leading businesses. One of those, Tata Consultancy Services, has made what the University calls a \$50 million "investment" in Cornell Tech, which "includes a significant gift for the first phase of capital development on the Roosevelt Island campus, as well as support for collaborating on technology research and expanding K-12 digital literacy programs in New York City."

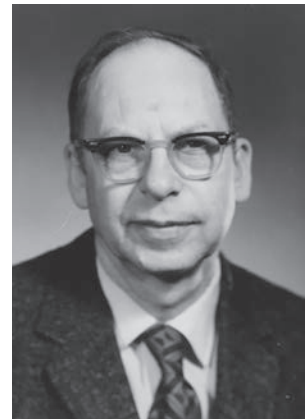

Oldest Emeritus Prof Dies at 107

Cornell's oldest living professor emeritus has passed away at the age of 107. Olaf Larson, a rural sociologist who taught on the Hill for seventy-one years, died in Florida on November 14. He published two of his books, including the autobiography *When Horses Pulled the Plow*, after turning 100.

Give My Regards to . . . These Cornellians in the news



Engineering Dean **Lance Collins** (left), winner of the inaugural Mosaic Medal of Distinction from Cornell Mosaic, an organization that promotes involvement with the University by diverse alumni.

Vincent Boudreau, PhD '93, named president of City College of New York. He had been serving on an interim basis for a year, after **Lisa Staiano-Coico, PhD '81**, stepped down amid allegations of financial impropriety.

Professors **Daniel Barbash** (molecular biology and genetics), **Amanda Rodewald** (ornithology), **Thomas Seeley** (biology), **Christine Smart** (plant pathology), and **Jessica Tyler** (pathology and laboratory medicine), elected fellows of the American Association for the Advancement of Science.



ILR student **Alex Hammond '18** (right), elected supervisor of his hometown of Waddington, New York, located near the Canadian border.

Lisa Schlitt '07 (left), who won \$15,400 in the "Jeopardy!" Tournament of Champions in November. The microbiologist had previously taken home \$139,100 on the game show.



Did You Know . . .

That two Cornell-related projects are vying for the Grammy for "Best Boxed or Special Limited Edition Package"? The nominees include the fortieth anniversary edition of the *Voyager Golden Record*—the "message from humanity" spearheaded by the late astronomy professor Carl Sagan—and *Get Shown the Light*, a recording of the Grateful Dead's legendary May 1977 show in Barton Hall.

PHOTOS: TECH; COLLINS; LINDSAY FRANCE (UREL); SCHUTT; JEOPARDY PRODUCTIONS; HAMMOND; PROVIDED; LARSON; PROVIDED; BOX SET, OZMA RECORDS

A GIFT FOR
GENERATIONS

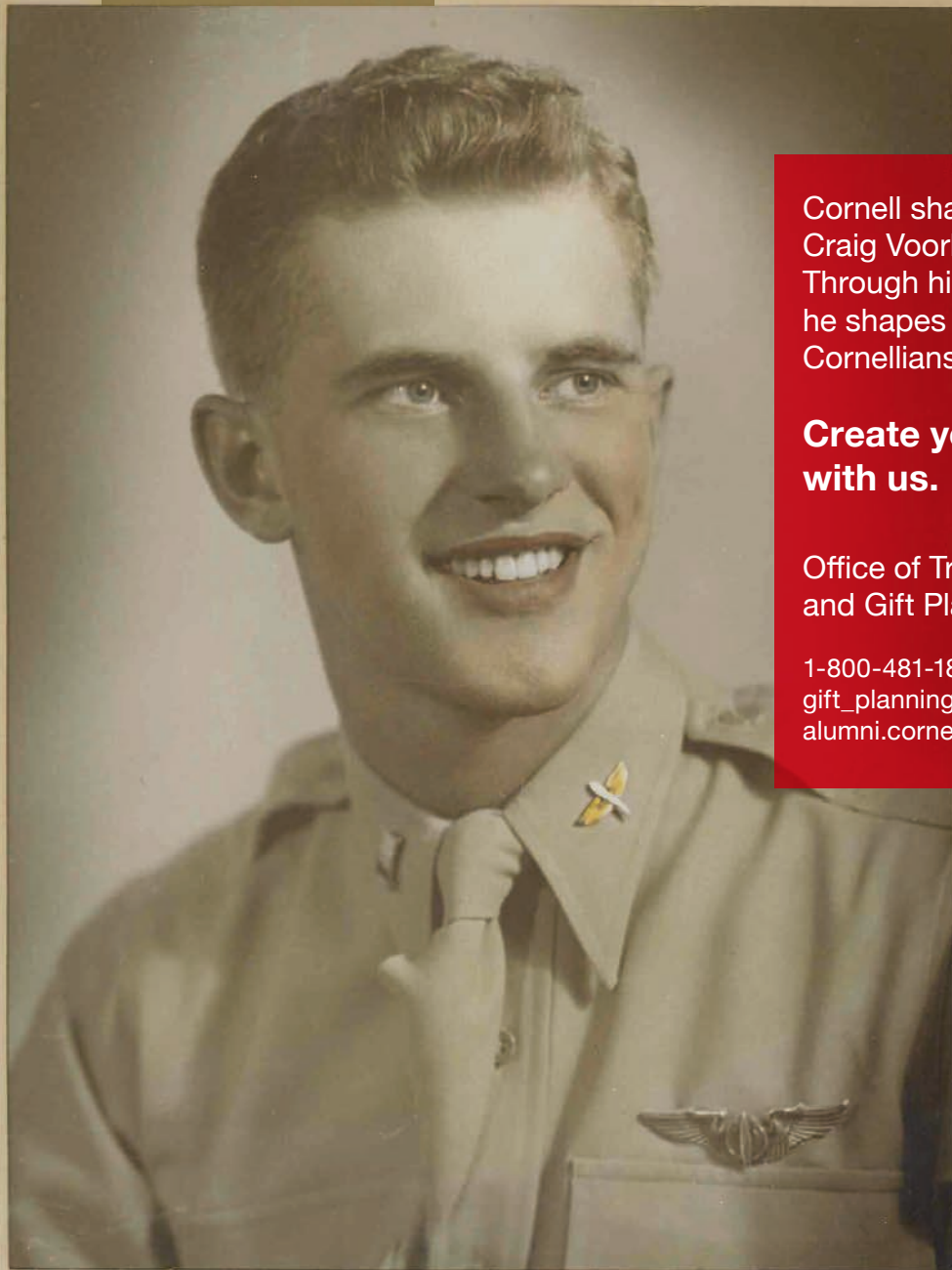

Cornell shaped
Craig Voorhees '49.
Through his bequest,
he shapes the future of
Cornellians to come.

**Create your legacy
with us.**

Office of Trusts, Estates,
and Gift Planning

1-800-481-1865
gift_planning@cornell.edu
alumni.cornell.giftplans.org

Read more about
Craig Voorhees at
giving.cornell.edu

Craig Voorhees beams in a US Army Air Forces portrait, circa 1944.
Photo provided by Carol McArdell, Voorhees's niece.

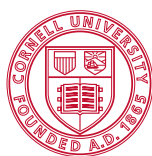

Cornell University

JOIN US!

for Cornell Silicon Valley's
premier event

March 13, 2018



Hear from Cornell's 14th president, **Martha E. Pollack**, in conversation with **Greg Morrisett**, dean of Computer and Information Sciences. Learn more about Cornell's newest campus—**Cornell Tech**. Take in game-changing presentations, and engage with Cornellians working at leading companies.

Register today at alumni.cornell.edu/csv/csv18

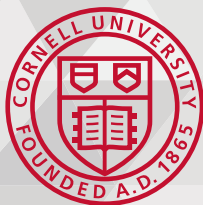

#CSV18

CURRENTS

FACULTY RESEARCH • CAMPUS LIFE • ALUMNI STORIES

SPEED RACER

Bobsledder Jamie Greubel Poser '06 has her sights set on a second Olympic medal

PHOTO: ACTION PLUS SPORTS IMAGES/ALAMY STOCK PHOTO

PUSHING AHEAD:
Greubel Poser (front)
competing in Lake
Placid in 2014



THE FAST LANE: Greubel Poser (front) in a World Cup race—which she and her partner would go on to win—in Park City, Utah, in November 2017. Below: Throwing the javelin for the Big Red during her undergrad days. Opposite page: In uniform for Team USA.

For Jamie Greubel Poser '06 and the bobsled, it was hardly a case of love at first sight. As the former Big Red track and field star recalls, her inaugural ride “felt like I got put in a tin can and kicked off a cliff.” That was back in 2007, when Greubel Poser briefly tried the sport in Lake Placid at the behest of a Cornell teammate who thought her combination of strength and speed would be a perfect fit. But that first plummet was a turn-off, and she went ahead with her plans for grad school. “Most women don’t play contact sports, so maybe if I had taken a hit in football or ice hockey I would have been prepared,” she observes. “In bobsled we go seventy-five to ninety-five miles

an hour and reach up to five Gs of pressure—it’s very intense. You hit walls and the only thing between your hip bone and the ice is the sled, which has a steel frame and no cushion. It’s an aggressive sport, and the first time it was pretty shocking to my body.”

Flash forward a decade: Greubel Poser is one of the world’s top women bobsledders—a 2014 Olympic bronze medalist with a good chance of mounting the podium again at the Winter Games in South Korea in February. Named her sport’s 2016 athlete of the year by USA Bobsled & Skeleton, Greubel Poser has amassed a slew of medals in World Cup competition over the past few years and landed on Olympic broadcaster NBC’s list of “athletes to watch” in PyeongChang. “Jamie is probably the most fearless athlete we’ve had on the women’s track and field team at Cornell,” says longtime Big Red assistant coach Rich Bowman. “She’s got great focus. Once she gets into a competition, she really locks in.” When Bowman heard that his former student had taken up the winter sport, he says it made a certain kind of sense. “I didn’t know much about bobsledding, other than that people had to be a little bit out of their minds,” he says with a laugh. “And from a track and field standpoint, Jamie would run through a brick wall to get what she wanted. She was a great competitor. When she was out there, she took no prisoners.”

As a high-schooler in Princeton, New Jersey, Greubel Poser was a standout athlete—running track, playing field hockey, and show-jumping horses. Competing for the Big Red, she won



Heps (the seven-event Outdoor Heptagonal Championship) three of her four years—she was injured as a sophomore—and set school records in the heptathlon and its indoor counterpart, the pentathlon. Her senior spring, she was named the class's outstanding female varsity athlete. "The male recipient was Kevin Boothe ['05, BS Hotel '06], and he went on to play in the NFL—and two years after graduation, he had a Super Bowl ring," says Greubel Poser, who entered the Cornell Athletic Hall of Fame in 2016. "Most women don't have many opportunities to pursue sports at an elite level post-collegiately. I wanted to, but I wasn't sure what avenue to pursue." But when she gave bobsled a second try—while still working on her master's in elementary education at Lesley University—she found it an ideal match for her talents. "When I got to compete in the sport, everything that I loved about being an athlete and being on a team came back to me," she says. "I think bobsled is the hidden gem of the sports world, especially for female athletes."

After completing her master's, Greubel Poser moved to Lake Placid to focus on bobsled, initially supporting herself by waitressing. (The sport, she notes, is an expensive undertaking, with athletes often responsible for costs like travel, shipping sleds, and owning multiple sets of runners—the sled's blades—which cost some \$6,000 a pair.) Her first major challenge was satisfying her coaches' requirement that she add twenty pounds to her five-foot-nine frame, reaching her current 170 pounds through weightlifting and diet. "Bobsled is a gravity sport—heavier things go downhill faster—so they cap the weight to make it a level playing field," she explains. "There's a maximum weight for the sled and the two athletes, and if you don't meet that you add lead plates. But that puts you at a disadvantage, as a smaller, weaker athlete pushing a heavier sled." Bobsledders train eleven months of the year, she says, with a long off-season; World Cup competition runs from November to January. "We train like Olympic weightlifters and sprinters—it's important for us to be strong, fast, and explosive, because we're moving a 365-pound sled from a standstill to top speed in about fifty meters, equivalent to five or six seconds," says Greubel Poser, who is married to a fellow bobsledder, Germany's Christian Poser. "In the off-season, we build our base of training for the year so when we start the bobsled season we're in top shape."

Like most bobsledders, Greubel Poser started off as a brakeman—the rear position—making the national team in 2009–10. After she failed to land a spot on the 2010 U.S. Olympic team, she decided to become a driver (the front position, also known as pilot), in part because it might give her a better chance of making it to the next Games, since there were fewer U.S. drivers on the World Cup circuit. That gamble paid off, ultimately leading to her bronze in Sochi. Bowman recalls watching

that medal-winning race on TV, viewing it in a group that was "jumping up and down, all excited" to see the former Big Red star compete on the world stage. "She got ready to get into the sled, and the camera did a pan of her eyes and they were just crazed—so fixed on what she was going to do," Bowman recalls. "I remember those eyes when she was at Cornell and got ready for a competition. It was like, 'Get out of my way—here I come.'" ■

— L. P. Drew

'From a track and field standpoint, Jamie would run through a brick wall to get what she wanted,' recalls her Big Red coach, Rich Bowman. 'She was a great competitor. When she was out there, she took no prisoners.'



FEAST YOUR EYES



Computer scientist Steve Marschner, PhD '98, helps Hollywood create virtual characters like Gollum, King Kong, and more

He was scrawny, malevolent, pathetic, terrifying—his desiccated body clad in a dirty loincloth, wisps of stringy hair dangling from his skull, bulbous eyes bloodshot, mouth a rictus of rotten fangs. When Gollum came into full view in the second *Lord of the Rings* film in 2002, he was hailed as a special effects marvel—the most realistic character created by computer graphics (CG) in the history of cinema.

Gollum's startling verisimilitude, and that of the CG creations who've come after, owe their existence not only to the Hollywood digital effects artists who designed them, but to the computer scientists who enabled that work in the first place. That makes Steve Marschner, PhD '98, one of Gollum's

godfathers—and he has the Academy Award to prove it.

A professor in Cornell's computer science department since 2002, Marschner is a longtime CG researcher. He specializes in rendering natural materials—like skin, hair, wood, and fabric—that can be devilishly difficult to depict realistically. “If you look at the history of computer graphics, we got really good at plastic early on,” says Marschner, chatting with CAM in his Gates Hall office last fall. “It’s a very simple material. It’s homogeneous, it’s smooth on the surface, and it doesn’t have a lot of structure. Manufactured materials tend to have those properties, but things that are natural are much more complicated.”

Take skin, on which Marschner did some groundbreaking work on translucency that helped make Gollum seem so life-like. As he notes, “Light doesn’t just reflect at the surface of the skin; it goes through it and interacts with the blood vessels, structures, and tissues below, and then it emerges. It’s much more complicated than, say, a ceramic cup”—he proffers a mug bearing the logo of Pixar, the famed animation studio where he spent last summer working with digital artists—“which is very opaque and homogeneous.”

Part of Marschner's research process is to tap expertise on the material in question, so he can study it at a more fundamental level than its outward appearance. Working on depicting wood, for instance, he has consulted with CALS forestry researchers; for fabrics, he's talked to colleagues in Human Ecology's Textiles and Apparel department. And in studying how to

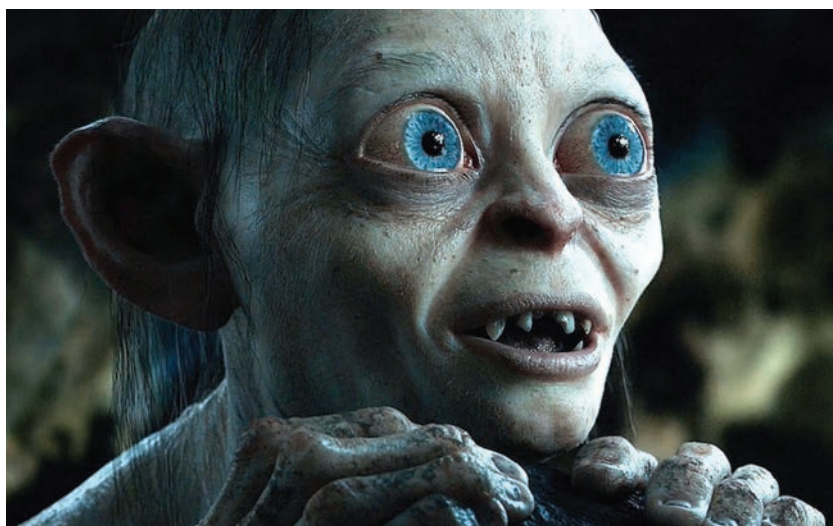

PHOTOS: MONSTERS, DISNEY PIXAR; GOLLUM, NEW LINE CINEMA

depict skin, he and his colleagues looked up medical physics literature regarding how to calculate dosages of laser therapy—since researchers in that field, he says, “have the same problem of how to compute how light bleeds through tissue.”

For the skin research, Marschner and colleagues won a 2004 technical Oscar. While that didn’t earn him a ticket to the star-studded red carpet ceremony that’s broadcast on TV, he did get to don a tux and accept the award—a plaque, featuring an image of the iconic statuette, that now graces his office wall—at a separate gala hosted by actor Jennifer Garner. “If you win the Oscar you get a statue,” he says with a laugh, “and if you win a technical Oscar you get a *picture* of the statue.”

Another major focus of Marschner’s research is hair, a substance that he says is much more challenging to depict than it may seem. The crux of the work—which has informed such animated films as *Tangled*, *Zootopia*, and *Monsters University* as well as live-action movies like the 2005 remake of *King Kong*—is understanding hair’s surprisingly complex structure, figuring out how that affects the way in which it reflects light (and therefore how we see it), and translating that knowledge to computer models.

While some people’s hair is made of round strands, he explains, in others they’re elliptical or flat. And the strands aren’t smooth; the surface is covered in scales, called cuticles, that are laid atop each other like roofing shingles. “Hair is interesting for a lot of reasons,” Marschner says, “but the most basic fact is that it’s made up of long, skinny objects. If you have perfectly combed hair, you’ll see a bright highlight that goes perpendicular to the fibers; in computer graphics, the geometry you need to figure out where that highlight happens has been known for a quite a while. But if you try to make things more accurate, you start to realize that hair is almost more like a glass cylinder than an opaque rod. Lots of light goes into the hair and



ACADEMIA AND THE ACADEMY: Marschner in Cornell’s Gates Hall (below). Left: The citation for his technical Oscar, which hangs in his office.



‘Light doesn’t just reflect at the surface of the skin,’ Marschner says. ‘It goes through it and interacts with the blood vessels, structures, and tissues below, and then it emerges.’

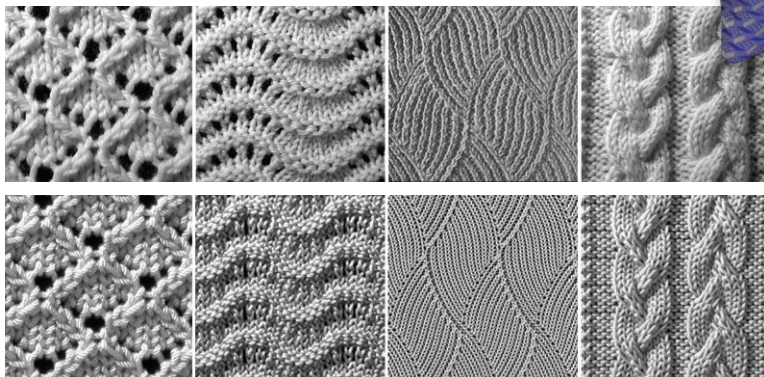

COMPUTER VISIONS (clockwise from above): Renderings of fabric-covered pillows; stitch patterns seen in photos (top row) and simulations (bottom row); Gollum in *The Lord of the Rings: The Two Towers*; and the stars of *Monsters University*



The Statler Hotel

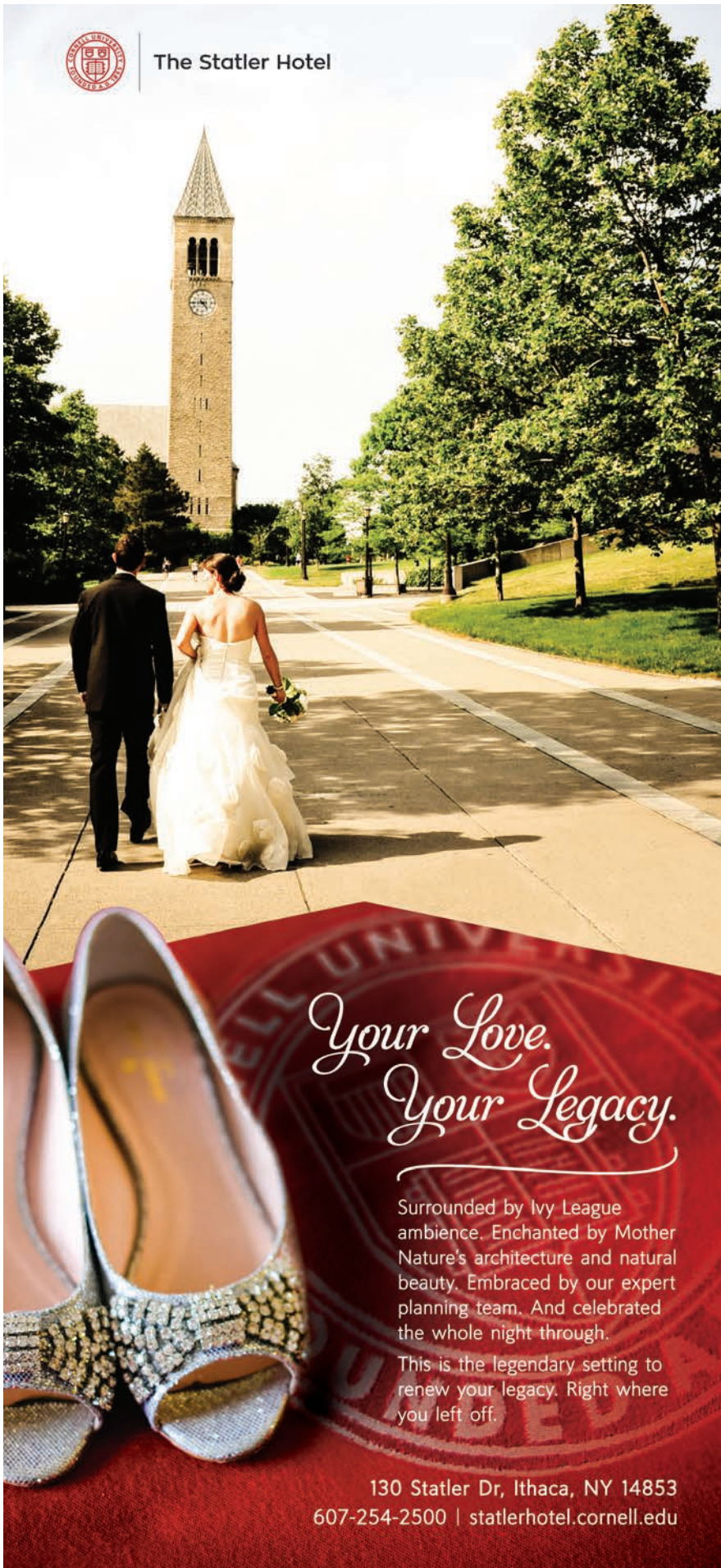

*Your Love.
Your Legacy.*

Surrounded by Ivy League ambience. Enchanted by Mother Nature's architecture and natural beauty. Embraced by our expert planning team. And celebrated the whole night through.

This is the legendary setting to renew your legacy. Right where you left off.

130 Statler Dr, Ithaca, NY 14853
607-254-2500 | statlerhotel.cornell.edu

refracts in and out, and the shape of the hair's surface has a lot to do with that."

Marschner's work doesn't just have applications in the virtual world. He's the co-founder of a start-up company, called Weft, that aims to let people design their own fabrics and order them online. The project, a collaboration with colleagues at the Rhode Island School of Design, is based on a computer model allowing for highly realistic depictions of potential fabrics, generated from the level of each woven strand. Marschner's research is also informing imaging that could help online shoppers—who can already view outfits modeled on rudimentary avatars of themselves—get a more realistic idea of what they're buying. "There's a difference between a polyester blouse that's designed to look silky versus one that's actually made from silk; it's got a little bit different drape and sheen," he says. "These things are subtle, but to make

Marschner's work doesn't just have applications in the virtual world. He's the co-founder of a start-up that aims to let people design their own fabrics and order them online.

buying decisions you'd like to be able to see them. That requires a lot of accuracy."

Asked if his insider knowledge of CG makes it harder to suspend his disbelief during a night out at the cinema, Marschner says that it depends—not so much on the technical elements, but on how good the film is. "The better the movie, the easier it is to not worry about the CG," he says. "Sometimes I say that I have to watch a movie twice—once to pay attention to all the graphics, and again to ignore them and just watch the movie." But, he adds, technology has advanced to the point where it can be hard even for experts to tell the real from the digital. "In the *Lord of the Rings* movies," he says, "I remember thinking that they did a really nice job on the CG for some of the remote villages and sets—and then watching the DVD extras and realizing that they actually built all that stuff." ■

— Kitty Kemp

**Wounded Warrior Project
helped me reclaim my life.**

I AM LIVING PROOF

WOUNDED WARRIOR
SEAN KARP



HELP MAKE AN IMPACT AT

iamlivingproofwwp.org

©2017 Wounded Warrior Project, Inc. All Rights Reserved.



WOUNDED WARRIOR
PROJECT

FAST FOODIE

Daniel Schwartz '01 is CEO of Burger King—plus Tim Hortons and Popeyes



HAVE IT YOUR WAY:

Schwartz (clockwise from top) speaking on campus, and working the ice cream cone machine and taking customer orders during his training at a Miami Burger King after becoming the company's CEO

Burger King customers in Miami may have encountered a certain hardworking trainee in the spring of 2013. Wearing a blue polo and a wide smile, he learned to do everything from making a Whopper to staffing the drive-thru. He scrubbed toilets, cleaned the dining room—sesame seeds, he found, get stuck in every nook and cranny—and took orders at the counter. But when the Friday of Memorial Day weekend rolled around, his manager told him not to report for duty: he just wasn't adept enough to handle the holiday rush.

It was an educational—and humbling—experience for Daniel Schwartz '01, then Burger King's newly minted CEO at just thirty-two. To get a grounding in the business's day-to-day realities, Schwartz—a CALS alum whose background is in finance—immersed himself in the tasks of the front-line worker. It wasn't an "Undercover Boss" arrangement; Schwartz's trainers knew his identity. And as a company video chronicling the process shows, they didn't go easy on him. "I think by the end I was doing a good job grilling burgers and making Whoppers," Schwartz recalls, chatting with CAM at the Statler during a recruiting

trip to campus last fall. "But I didn't quite perfect the art of the ice cream cone swirl. It was embarrassing—it'd always come out lopsided." But was it challenging for workers to school the top exec? "I think the first day was a little awkward, and after that it was fine," he says. "Once they saw how poorly I made the ice cream cones, they realized I had way more to learn from them than they did from me."

'I think by the end I was doing a good job grilling burgers and making Whoppers,' Schwartz says of his hands-on training. 'But I didn't quite perfect the art of the ice cream cone swirl.'

Running one of the world's biggest fast-food chains was hardly on Schwartz's radar when he majored in applied economics and management on the Hill. Growing up on Long Island, he figured he'd go into medicine or dentistry, but fell in love with finance. "Dan is an unusual combination of nice and amazingly accomplished," says his former adviser, Deborah Streeter, a professor in the Dyson School. "He's very driven and ambitious, but he's also a wonderful person. I didn't do much advising, because Dan always pretty much knew what he wanted to do." >



A fresh blanket of powder and sunny skies mean getting out and enjoying the great outdoors. Because for Kendal residents like Joan and Don, spending more time experiencing the changing seasons is important — especially now that they have the time to do it.

Living on the 105-acre campus at Kendal not only keeps them involved in the lifestyle they love, but connected to any future care they may need. And, from here, the story just keeps getting better.

Come for a visit and tell us your story. Call 1-800-253-6325 or go to kai.kendal.org to learn more.

2230 N. Triphammer Rd., Ithaca, NY 14850

KENDAL® at Ithaca
Together, transforming the experience of aging.®

Study in Rome Fall 2018

The Foundations in Architecture program offers students from around the globe a transformative opportunity to study in the Eternal City for a memorable semester with Cornell in Rome.

Learn more about admissions, classes, field trips, and costs, at rome.cornell.edu.

Special Offer:

Mention CAM and receive a free bus pass for use during your semester in Rome.

rome.cornell.edu
aap-admissions@cornell.edu

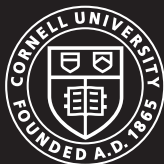

AAP
Architecture
Art
Planning

Schwartz finished his degree in three years and went to work on Wall Street, eventually landing at the Brazilian investment firm 3G Capital. When it purchased Burger King in 2010—Schwartz had identified the chain as a solid acquisition—he was named CFO. He quickly made some dramatic changes, such as replacing the traditional executive suites with an open office plan and selling the corporate jet, and a few years later he was promoted to the top job. “It’s less about cost-cutting than about creating an ownership environment,” he explains. “If it’s your own money, you turn the lights off when leave the room, and you probably treat the car you own better than one you rent.”

Among the lessons Schwartz gleaned from his front-line training was that the Burger King menu was too large and complicated, so he initiated a review process that resulted in it being trimmed down. He vastly reduced the number of corporate-owned restaurants, shifting them to franchises, and made menu improvements such as switching to 100 percent butter in the breakfast croissant. “We’ve grown same-store and system-wide sales,” he says. “Being more efficient allows us to focus and achieve that.” After Burger King merged with Tim Hortons, the Canadian coffee and donut stalwart, they formed a new company called Restaurant Brands International; it has since added Popeyes Louisiana Kitchen, the fried chicken chain, with Schwartz in charge of all three.

Schwartz, who lives in Miami with his wife and two small children, spends much of his life on the road. As he told *Business Insider*—in a 2017 story headlined “How a 36-year-old Wall Street prodigy saved Burger King”—he essentially lives on an American Airlines 737. He makes regular trips back to campus, both for executive recruiting and to speak to students; when he gave a lecture at the Hotel school in 2016, his bio noted that he can make a Whopper in under thirty-five seconds. “If you saw him on campus when he comes to visit, just carrying a backpack, you’d think he was a graduate student or even an undergraduate,” says Streeter, who calls Schwartz one of her highest-achieving alumni. “He doesn’t look like the buttoned-down CEO type.” ■

— Kitty Kemp



LAKEWOOD VINEYARDS
 Exceptional wine since 1988.

Alumni-owned & operated
 Chris Stamp '83
 Elizabeth Myer Stamp '85
 Teresa Stamp Knapp '90
 Benjamin Stamp '11
 Abigail Stamp '13

Tasting & Sales:
 Mon-Sat 10-5, Sun 12-5
 4024 State Route 14
 Watkins Glen, NY 14891
 877-535-9252
 lakewoodvineyards.com



Dr. Konstantin Frank
 55th Anniversary
 1962-2017

The winery that started a winemaking revolution in the Finger Lakes...

Open Year Round:
 Mon-Sat 9am-5pm, Sun 12-5pm

www.drfrankwines.com





Weill Cornell Medicine

Don't just study healthcare:
 change it.

M.S. in Healthcare Policy and Research

Tracks in:

- Biostatistics and Data Science
- Health Informatics
- Health Policy and Economics

hpr.weill.cornell.edu/education

LETTER PERFECT

Joe Strandberg '10, BS '09, aims to resurrect a late, lamented IBM keyboard



IN THE KEY OF 'F': Strandberg with deconstructed versions of the IBM Model F keyboard

It was the soundtrack of the Eighties-era office: the clickety-clack of the computer keyboard. More often than not, the instrument at hand was an IBM Model F (or its cheaper cousin, the Model M)—a keyboard that lives in legend among vintage hardware aficionados as the finest ever designed. Manufactured from the early Eighties to the mid-Nineties under a now-expired patent, the keyboards were rock solid—encased in steel and weighing some ten pounds. Their price tag in today's dollars: a whopping \$850. "The Model F was the result of millions of dollars in IBM research and development—it was built up to a quality standard, not down to a price point," says Joe Strandberg '10, BS '09, who first used one on his family's home PC as a child. "It's comfortable to use, and you get sound and tactile feedback from the clicks and the weight of the springs, so you can type more accurately. It's just a beautiful keyboard."

Strandberg is part of an online community of hobbyists who swap info about old-style mechanical keyboards on sites like geekhack.org. For a few years, the former applied economics and management major was restoring vintage Model Fs, mainly sourced from electronics recyclers. "But I grew frustrated that the 'best keyboard ever' required hours of effort and a good

The original Model F, Strandberg says, 'was built up to a quality standard, not down to a price point.'

deal of technical know-how to get it cleaned up and working on modern day computers," says Strandberg, an analyst at a financial research firm in Manhattan. "There are all these tiny springs and other parts in it, and if one thing is off, it doesn't work that well."

So in 2014, Strandberg decided to manufacture them >



The Hill is where
the heart is.

Reunion 

June 7-10, 2018

Start planning your stay in Ithaca!

Visit alumni.cornell.edu/reunion
for information on hotels and dorms,
and more!

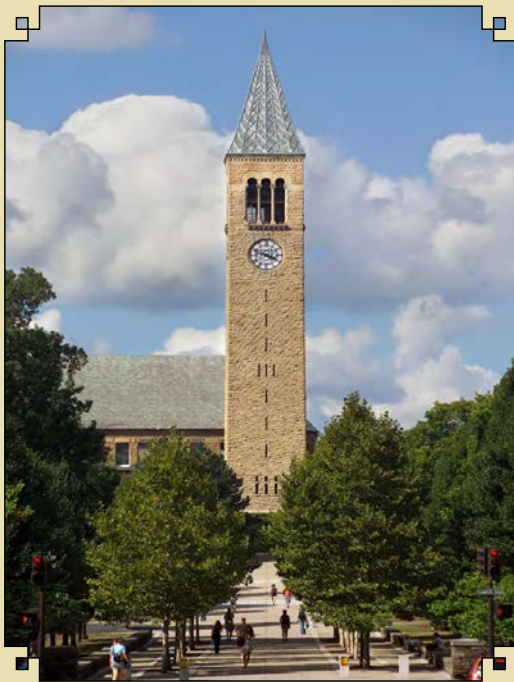

Cornell University
Library

*Do you have
a favorite
professor
who made a
difference in
your life?*

You can now honor them in perpetuity by naming a faculty study in Olin Library. Faculty studies are where many faculty members spend hours conducting research and writing their latest manuscript. Honor their teaching, enlightenment, and guidance in a place where knowledge and scholarship are at the heart of Cornell.

For more information, please contact
Jennifer Sawyer at (607) 255-9568 or jds367@cornell.edu



from scratch. Working on the project during nights and weekends, he did extensive research—including having a lab analyze the original key springs to determine their grade of steel—and contracted with a factory in China to produce them. Rather than fundraising via Kickstarter, he created a website (modelfkeyboards.com) for pre-orders, figuring he'd sell about 100. As of early December 2017—thanks in part to coverage in *Popular Mechanics* and on NPR—he'd sold more than 950, totaling more than \$430,000 in revenue. "It's been just crazy," he says. "This is beyond my wildest expectations."

The road to keyboard nirvana has not run smooth: Strandberg has had to push back his shipping date numerous times due to production issues.

**'It's been just crazy,'
Strandberg says of his
more than 950 orders.
'This is beyond my
wildest expectations.'**

"For example," he says, "the cases are made with a special process of powder-coating to get them to look like the old splotchy-textured paint of the originals, and that took the factory six months to figure out. And if you use the wrong material for the springs, they make a sound that is a little too high-pitched. There's a lot of detail work."

The keyboards, which are still available for order and are compatible with both PCs and Macs, are priced at \$325 to \$399. They're offered in both the boxy-looking classic style (which comprises about 80 percent of orders) and a sleeker modern version.

PHOTO PROVIDED: DIAGRAM, IBM

WE ARE YOUR FLORIDA CONNECTION!



Sarasota, Bradenton, Longboat Key, Siesta Key & Anna Maria Island...

...these are favorite destinations for New Yorkers and we have the perfect spot for your Florida retreat - any time of the year. Voted the Favorite Real Estate Company in the area 18 years in a row, Wagner Realty is owned and operated by Cornell Alumnus David Eckel. Whether you're interested in residential sales or rentals, commercial property or a winter getaway, we want to be your Florida Connection!



Check our website:
www.WagnerRealty.com
1-888-691-1245
or 941-727-2800



TRUE TO TYPE: The classic Model F keyboard (above) comprises 80 percent of Strandberg's orders. Below: Illustrations from the original patent for the key spring mechanism that was issued to IBM in 1978.

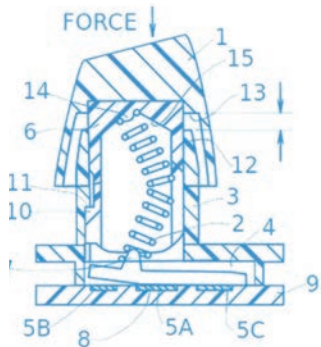
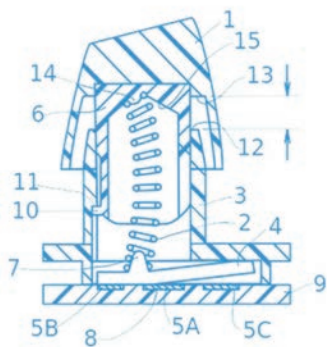

Strandberg hopes they'll begin to ship in the first quarter of 2018; he plans to manufacture some extras to sell until his inventory is exhausted, but since it's a limited production run, once they're gone they're gone. Open-ended production isn't financially feasible, he explains—and anyway, he's about ready to move on. "I've been working on this project for years, over e-mail late at night because [New York and China] are twelve hours apart, so I've lost a lot of sleep," he says. "It's going to be great the day the first keyboards ship. Then we'll be able to say we did it—and I can get some rest." ■

— Kitty Kemp

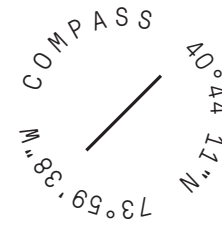

Moving to New York City?

Scott Fava
Class of '01



For all of your real estate needs in Manhattan and Brooklyn, contact Scott Fava, one of New York's elite real estate brokers.



Scott Fava

Licensed Associate Real Estate Broker
fava@compass.com 917.841.7330



Private Mortgage Banking

Unparalleled knowledge and service



My goal is to provide you with the mortgage options you need, delivered with the exceptional service you deserve.

Home financing available in all 50 states

Vincente William Stasolla - '93
Private Mortgage Banker
412-454-4651
NMLSR ID 148704

Information is accurate as of date of printing and is subject to change without notice. Wells Fargo Home Mortgage is a division of Wells Fargo Bank, N.A. © 2014 Wells Fargo Bank, N.A. All rights reserved. NMLSR ID 399801. AS3092879 Expires 01/2018



ON THE BALL

The Engineering college's Matan Presberg '18 has juggled his way to multiple world records

Matan Presberg's T-shirt reads "Juggling is My Cardio"—and it's no joke. It's a fall afternoon in Barton Hall, and the senior computer science major is working up a sweat as he demonstrates one of his favorite combinations, a pattern of tosses and catches in which he starts off by sending four balls whipping around his neck. He then maneuvers them to the front of his body and makes them soar through the air in a figure eight, his movements controlled and fluid even as he moves at hyper speed. "Juggling is an art and a sport," says Presberg, whose expertise has earned him fifteen world records and myriad other honors. "It's about focus and thinking multiple steps ahead."

The current president of the Cornell Juggling Club, Presberg aims to practice two hours each day as he trains for competitions in the U.S. and Canada. During the warmer

Juggling, Presberg says, 'is about focus and thinking multiple steps ahead.'

months, he's a familiar sight on the Arts and Engineering quads; in the winter he relocates to Barton Hall, whose high ceilings can accommodate his thirty-foot throws. "When I'm focused and practicing, I get into a zone," says Presberg, whose juggling playlists range from rock to metal to punk. "I have an internal running dialogue where I'll try something and then analyze it."

Presberg has been juggling for most of his life: he got hooked as a kindergartener after seeing a performance by a club in his native Rochester, New York. He began attending its weekly practices and soon set a world record by "juggling his age"—six balls. He has since amassed fourteen more, including the record for completing the most four-ball catches (a total of 108) with his eyes closed and for completing the most nine-ball catches (39)



NICE CATCH: Presberg practicing in Barton Hall last fall (above) and performing in a campus arts showcase in spring 2017 (left)



thrown from varying heights. In addition, Presberg is a three-time winner at the International Juggling Association Numbers Championship, where he earned gold medals for making the most consecutive catches with the greatest number of balls: using nine balls, he made twenty-five catches in 2015, twenty-eight in 2016, and thirty-three in 2017.

Presberg practices not only technical juggling—which focuses on factors like the number of objects and consecutive catches—but also the "artistic" style, which uses fewer balls and incorporates props, dance, and music. He has performed his routines—such as balancing a hatchet on his nose while juggling three balls—at juggling events on the Hill and at other schools including MIT and Case Western Reserve. Last fall, he took a dance composition class on campus with the aim of expanding his talents. "What I love most about juggling," Presberg says, "is that there are infinite possibilities." ■

— Kayleigh Rubin '19

CAU | CORNELL'S
ADULT
UNIVERSITY

cau.cornell.edu

Israel *and the* Palestinian Territory

May 22–31, 2018

SPECIAL TRAVEL SECTION



led by
Ross Brann
the M. R. Konvitz Professor of
Judeo-Islamic Studies

- Join **Ross Brann** as he illuminates the complexities of this troubled region on a tour of Jerusalem, Tel Aviv, Bethlehem, and Ramallah. Learn the history of long-standing conflicts and ponder the possibility of a peaceful resolution.

Read about this and other CAU study tours at cau.cornell.edu.

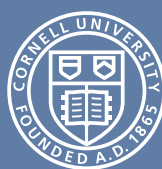

MOBILE HOME

Eschewing Collegetown rents, Eli Shanks '18, BS '17, spent his final semesters living in a converted school bus



WHEEL ESTATE:

Eli Shanks '18, BS '17, inside (above) and outside (left) the converted bus in rural Trumansburg that he called home for the latter part of his Cornell career

By the time you read this, Eli Shanks '18, BS '17, will have decamped to roomier accommodations. But for the last year and a half, the CALS student made his home in a decommissioned school bus, parked roughly ten miles from campus in the countryside of Trumansburg.

Complete with bathroom, pellet stove, oven, fold-up bed, shower, and wireless internet, the cozy abode has all—or at least most—of the comforts of home. It even has its own power source: six solar panels affixed to the outside provide energy for most of the appliances, from refrigerator to vacuum cleaner. “I way overestimated with the solar power,” he says with a laugh, chatting with CAM last fall, weeks before completing his degree in December and graduating a semester early. “I could probably get away with a fifth of the energy. If somebody wanted to put in a projector and entertainment system, they’d probably still have three times what they need.”

Shanks spent the summer after sophomore year laboring to transform the bus, a 1993 AmTran Genesis that he affectionately dubbed the “Command Post” in a nod to its role at the police department that was its second owner. It’s a significant upgrade from his former domicile, a gusty old apartment on the outskirts of Collegetown where rent and utilities were steep. “Last winter here, I spent \$400 total on heating—which is what I spent in a month heating that other house,” notes Shanks, a double major in agricultural science and applied economics and management whose unconventional lodgings prompted coverage in the *Ithaca Voice* and *Daily Sun* last fall.

According to Shanks—who parks his bus on land donated

by an acquaintance—this type of home isn’t as uncommon as you might think. School districts replace their buses well before their lifespan is up, and a full-sized vehicle can be had for \$1,000 to \$1,500; shorter ones, which tend to be in higher demand, run \$3,000 to \$5,000. “It’s a lot cheaper than an RV,” says Shanks, who notes that he bought his nearly full-size bus (which was laden with extra equipment from its police days) from a municipal auction in Pennsylvania for \$4,100—then sold the generator that came with it for \$4,300 and the air conditioner for a few hundred more.

Because school buses are built on a semi truck frame, Shanks notes, “they’re designed to go one or two million miles.” So with 145,000 miles on the odometer, the Command Post is practically brand new. At 232 square feet, it can comfortably host a

At 232 square feet, the bus can comfortably host a party of fourteen people, particularly if the bed has been folded up into a couch.

party of fourteen people, particularly if the bed has been folded up into a couch. Shanks sometimes had smaller, less-welcome guests, too. “The mice here are way too smart,” he says. “They snap all the traps and eat the peanut butter without getting caught. How do they do it?”

After his December graduation, Shanks moved to Chile to be with his partner and their baby—and before he left, he sold the bus for nearly four times what he’d paid. The experience has left him itching to repeat the project. “In Chile,” Shanks says with an eager smile, “they have some cool double-decker buses.” ■

— Alexandra Bond '12

Gorges

MEETINGS & CONFERENCES



Retreat

TO ITHACA

**Are you a member of a trade or academic association?
Are you part of an executive team?**

Ithaca now boasts a unique variety of memorable venues, with both traditional and creative business spaces, for groups from 10 to 250+.

Host, plan, learn more at IthacaMeetings.com



GATHERING HILL
· FARM ·



GRACIOUS VACATION RENTAL & EVENT SPACE
1816 FARMHOUSE ON 8 ACRES IN THE HEART OF FINGER LAKES WINE COUNTRY
PERFECT FOR LARGE GROUPS, REUNIONS & CORNELL VISITS

4180 STATE RTE 414, BURDETT NY ~ GATHERINGHILLFARM.COM
NICOLE VON SUHR, ARTS AND SCIENCES '87, OWNER

amazonsmile
You shop. Amazon gives.

Support
Cornell Alumni Magazine!

Go to Amazon Smile
by visiting
smile.amazon.com

When you're there, select
Cornell Alumni Magazine
as your charity of choice!

SALT
& WIND
TRAVEL

**BOUTIQUE
TRAVEL FOR
CURIOUS
FOOD LOVERS**

HOSTED BY
AIDA MOLLENKAMP
CLASS OF '02

15% OFF CODE **CORNELL15**
TRAVEL.SALTANDWIND.COM



#07251

**Cornell Big Red
Full-Zip Sweatshirt**

This must-have women's hoodie features a cowl neck hood, raglan sleeves and front pockets. Embroidered with Cornell Big Red and a Cornell C on the front.

store.cornell.edu



Sublime...

Luxury Barge Cruises



FRENCH COUNTRY WATERWAYS, LTD.
P.O. Box 2195, Duxbury, MA 02331
800-222-1236 781-934-2454
www.fcwl.com

**Food & Beverage
Special Ad Section
May/June 2018**



Reserve space by
March 15, 2018.
Contact Sandra Busby
SLB44@cornell.edu
800-724-8458 x23



Pedal Your Passion in 2018

Come Spin Tuscany,
Piedmont, Sicily,
Sardinia and more!



*The Specialists in Italian
Bicycle Vacations Since 1989*

Ciclismo
CLASSICO
PEDAL YOUR PASSION

Director and Founder,
Lauren Hefferon '83

1-800-866-7314
ciclismoclassico.com

Your Regional Airport

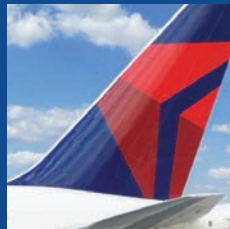

DELTA

RESERVATIONS
1-800-221-1212

BAGGAGE SERVICE
1-800-325-8224



American Airlines

RESERVATIONS
1-800-433-7300

LOCAL DESK
800-535-5225



UNITED

RESERVATIONS
1-800-864-8331

BAGGAGE SERVICE
1-800-335-2247

Ithaca Tompkins Regional Airport has competitive pricing, unparalleled convenience, and the most customer friendly staff around. Daily flights to Detroit, Philadelphia and Newark. With three airlines to choose from, you have an opportunity to fly to over 700 one-stop destinations around the world.

We look forward to serving your air travel needs in 2017.

One-stop
connections to
over 700 global
destinations

ITH
flyithaca.com

Ithaca Tompkins Regional Airport | 1 Culligan Drive Ithaca, NY 14850

New Releases

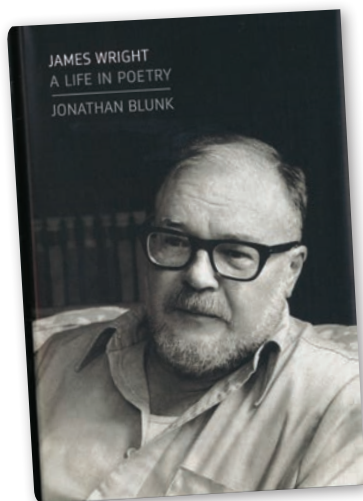

**James Wright:
A Life in Poetry**
JONATHAN BLUNK '80, BA '81

Kirkus lauds Blunk's portrait of the late Pulitzer Prize-winning poet as "a much-needed, engaging, and discerning biography that should help Wright find a new generation of readers." Drawing on more than 240 interviews and a collection of Wright's letters to family and friends,

Blunk chronicles the poet's life—including his battles with mental illness, his alcoholism, and his obsessive fixation on his work—as he traces the evolution of his writing style. Blunk first encountered Wright's oeuvre during a class in Goldwin Smith, and the English major went on to write an honors thesis on Wright's translations of German, Spanish, and Latin American poetry. As part of his research, Blunk scheduled interviews with Wright—but those plans were canceled when the poet was diagnosed with terminal cancer. In his book, Blunk describes how, following his prognosis, Wright was determined to complete his final volume, *This Journey*; on the morning of his death, his doctor found him agitated and pacing. "My book, my book," Wright kept repeating," Blunk writes. "Spring sunlight filled the windows and he could hear birds singing. He had always found daybreak the best time for writing."

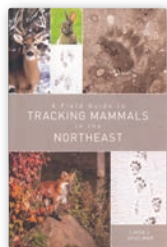

A Field Guide to Tracking Mammals in the Northeast
LINDA SPIELMAN, PHD '83

Drawing on her twenty-five years of experience as an environmental educator and coordinator of tracking groups in the Ithaca area, the plant pathology alumna offers advice on tracking mammals—from chipmunk to bear, coyote to moose—that are found between Pennsylvania

and Maine. The book includes explanations of tracking techniques, illustrations of pawprints, and descriptions of each animal's habitat and identifying characteristics such as claw marks and scat. "Tracking is a skill anyone can learn," Spielman writes. "And it holds the power to reveal unseen events—which animals come and go, what they pay attention to, and how they interact with each other and with their surroundings."

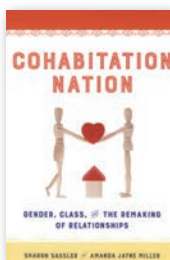

Cohabitation Nation

SHARON SASSLER

Between 1990 and 2010, the number of unmarried heterosexual couples living together more than doubled, from 3.2 million to 7.5 million. Informed by more than 130 interviews with cohabiting partners, Sassler—a social demographer and professor of policy analysis and management at Cornell—and her co-author examine this trend and discuss who moves in together and why. Their book tackles topics such as the decision to cohabit, contraception, housework, and finances. The authors also use couples' stories to explain how social class and gender norms influence the progression of romantic relationships, from dating to contemplating marriage.

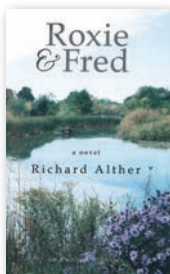

Roxie & Fred

RICHARD ALTHER '62

Alther, a novelist and painter who splits his time between California and Vermont, sets his fourth book in a woodsy cabin, which becomes the setting for an unconventional romance between eighty-eight-year-old Roxie and forty-eight-year-old Fred. When they meet in a drawing class, they form a friendship that quickly evolves into a passionate affair. "Roxie eclipses all else," Alther writes in Fred's third-person narration. "He regards her an angel, himself an ox. How untenable his passing fancy, but for now, hold on tight."



Lily's Mountain

HANNAH MODEROW '06

In her debut novel for middle-grade readers, Moderow—an English and art history double major who grew up in Alaska in a family devoted to dog sledding and other outdoor pursuits—follows a twelve-year-old girl who's racing against time and battling the elements to rescue her father from the top of Denali, North America's highest peak. After hearing that her dad, an experienced mountaineer, has died attempting an ascent, Lily refuses to believe it and convinces her sister to join her on a dramatic quest to save him. *Publishers Weekly* praises the book as "an engrossing portrait of a girl's devotion to her father and how she makes the most of everything he taught her."

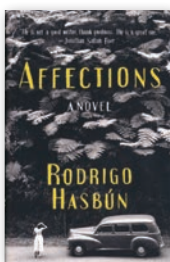

Affections

RODRIGO HASBÚN, PHD '16

The Bolivian novelist's English-language debut is a fictionalized story about the real-life Ertl clan, a German family of Nazi sympathizers who fled to Latin America after World War II. The plot, which unfolds from multiple points of view, depicts a half-century of internal strife set against the backdrop of the region's political upheaval. The family patriarch, a former Nazi cinematographer, leads two of his daughters on a quest to uncover a fabled lost Incan city—and along the way, the eldest becomes a Marxist guerilla. *Kirkus* calls the brisk 120-page read a "one-sitting tale of fragmented relationships with a broad scope, delivered with grace and power."

To purchase these books and others by Cornellians, or to submit your book for possible mention in *Cornell Alumni Magazine*, go to cornellalumnimagazine.com/authors.



Have you been here yet?

UNESCO World Heritage Sites are preserved and protected because they are deemed important to the collective interests of humanity. With this awesome thought in mind, we visit many UNESCO sites each year. Can you match these UNESCO World Heritage Sites to their countries?

- | | |
|---------------------------------------|--------------|
| A. CUZCO | 1. MOROCCO |
| B. CARCASSONNE | 2. AUSTRALIA |
| C. HUE | 3. JAPAN |
| D. AGRA FORT | 4. COLOMBIA |
| E. ULURU-KATA TJUTA NATIONAL PARK | 5. PORTUGAL |
| F. AIT-BEN-HADDOU | 6. VIETNAM |
| G. SHIRAKAWA-GO GASSHO-ZUKURI VILLAGE | 7. FRANCE |
| H. CIUDAD AMURALLADA | 8. PERU |
| I. EVORA | 9. INDIA |

Good job! Now it's time to experience them for yourself!

Check out our website for details about our 2018 and 2019 tours! Cornell alumni, parents, and friends welcome!

ANSWERS: A-8; B-7; C-6; D-9; E-2; F-1; G-3; H-4; I-5

Big Red Highlights



FIELD HOCKEY **Krysten Mayers '18** finished the season as Cornell's all-time leader in career goals (42) and points (99), breaking both previous records with an overtime goal in a 2-1 win over Brown in October. Mayers was one of four Big Red players to earn post-season honors from the Ivy League, the most since 2014. Defensive anchor **Sam McIlwrick '18** was a unanimous first-team All-Ivy pick, while Mayers and **Maddie Henry '20** were second-team honorees and **Maddy Conklin '20** earned honorable mention. In addition to the players' success, head coach Donna Hornibrook collected her 300th career win in the season finale as Cornell finished 10-6, marking double-digit wins for the fifth straight season.

MEN'S HOCKEY The Big Red got off to its best start in more than 45 years, winning its first seven games. The squad's most dramatic victory came against Harvard. After the Crimson took a 2-0 lead in the first period, the Big Red tied it up early in the second. The score remained 2-2 throughout most of the second and third periods before defenseman **Alec McCrea '19** slipped in a shot with just 2.3 seconds left on the clock.

MEN'S TENNIS For the second straight season, Cornell sent a player to the finals of the Inter-collegiate Tennis Association Northeast Regionals. **David Volfson '19** didn't give up a set in five straight wins before losing the championship

match. Volfson reached the semifinals as a freshman in 2016, but missed the tournament last season due to injury; it was won by **Chris Vrabel '17**.

WOMEN'S SAILING Cornell finished 12th at the Atlantic Coast Championship Regatta, its best showing since earning varsity status in 2012. The tandem of **Gabby Rizika '20** and **Tara Bergstrom '18** were 13th in the A Division, posting top 10 finishes in eight races including one in first place.

VOLLEYBALL The Big Red enjoyed its best Ivy finish since 2006, going 8-6 in conference play to end up tied for third, and finishing the regular season 12-11. Trudy Vande Berg was named Ivy Coach of the Year while three players earned post-season honors. **Kiley McPeck '18** was a first-team All-Ivy pick—Cornell's first since 2008—after leading the league in digs per match (which counts the number of times a player makes the initial defensive contact with the ball). **Jenna Phelps '20** was a second-team selection after leading the Ivies in service aces per set and coming in second in blocks. **Kit McCarty '18** (seen above in a September game against Columbia that the Big Red won 3-1) received honorable mention for the second time.

WOMEN'S TENNIS **Priyanka Shah '18** provided two of the season's biggest highlights, reaching the round of 16 in the ITA Northeast Regional and finishing second in the top flight of the Cissie Leary

Invitational. Shah, who was seeded fifth at the Invitational, upset the top seed in the semifinals but lost the three-set championship match, which lasted three and a half hours.

FOOTBALL Wins over Harvard, Brown, and Princeton gave Cornell its first three-game Ivy winning streak since 2005 and put the Big Red in a tie for first place in November, a position it hadn't been in for decades. While the win over Brown was dominant (34-7), the other two were comeback victories, with Cornell rallying from a 14-0 deficit against Harvard to win 17-14 and outscoring Princeton in the fourth quarter (13 points to none) to win 29-28. It was Cornell's first win over Harvard since 2005 and its first against Brown since 2007.

ALUMNI NEWS

ROWING Two former Cornell rowers earned silver while competing for Team USA at the 2017 World Championship in Florida. After taking home gold in women's quadruple sculls in 2015, **Tracy Eisner '12** switched to pairs in 2017 and finished second, losing only to the current world record holders. In the men's eight, **Alex Karwoski '12** (whose boat finished fourth at the 2016 Olympics) also brought home silver, finishing behind Germany. Big Red men's rowing was represented at the worlds by three other alumni—**Michael Colella '16**, **Christopher Lambert-Rogers '15**, and **Jack Ruske '17**—who finished out of medal contention.

MEN'S HOCKEY **Joakim Ryan '15** became the 30th Big Red alum to play in the NHL when he suited up for the San Jose Sharks against the Buffalo Sabres on October 12. He saw more than 21 minutes of ice time in his debut and later notched his first NHL point with an assist against the Nashville Predators on November 1.

WRESTLING **Gabe Dean '17**, a four-time All-American and two-time national champion, is helping his former team as a coach, serving as a volunteer assistant for 2017-18. Dean has remained in Ithaca since graduation, working with the Finger Lakes Wrestling Club and training for a post-collegiate wrestling career.

WOMEN'S HOCKEY **Melanie Jue '10** is blazing new trails in professional women's ice hockey as the sport makes an expansion into China, which is building its program in preparation for the 2022 Winter Olympics in Beijing. A Chinese-Canadian from British Columbia, Jue played both ice and field hockey on the Hill. Now she's on defense for the Kunlun Red Stars, one of the two new Chinese teams in the Canadian Women's Hockey League. Based in Shenzhen, the team features a mix of North American and Chinese players.



THE CORNELL CLUB

N E W Y O R K

Your home in the heart of Manhattan!

Stay in touch with fellow Cornellians by joining The Cornell Club-New York! As a Member of The Club, you have access to the clubhouse and its facilities, featuring:

- Programs & Events
- Health & Fitness Center
- Library
- Dining Rooms
- Guest Rooms
- Banquet Facilities
- Cayuga Lounge
- Business Center
- Over 100 Reciprocal Clubs

For more information on membership, please contact the Membership Office at 212.692.1380 or membership@cornellclubnyc.com or visit www.cornellclubnyc.com

We hope to see you at The Club soon!

Reconnect. Reminisce. Relax.

The Cornell Club-New York 6 East 44th Street New York, NY 10017



Your Connection to the Big Apple
#ExperienceC2C

www.c2cbus.com



Cornell University Summer College

Programs for High School Students

Courses in architecture, business, engineering, international relations, social change, veterinary medicine, and more

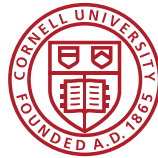

- Study with Cornell faculty
- Earn college credit
- Prep for college applications
- Make friends from around the world

SUMMERCOLLEGE.CORNELL.EDU

Cornell's Adult University (CAU) Summer Youth Program and Camp



Four weeklong sessions, July 8 – August 4

Youth ages 3–15 get a wonderful taste of college life at Cornell and enjoy the fun and friendships of a great camp

cauinfo@cornell.edu • cau.cornell.edu • 607.255.6260

Unleash your voice through argument, debate and community

INTERNATIONAL SUMMER DEBATE CAMP

July 29 – Aug. 5, 2018
Ages 13-19

**Big Red Family Discounts!
APPLY NOW**



Cornell University

summerdebatecamp.cornell.edu



BROWN | Pre-College

Experience College This Summer

Students in Grades 7-12 Prepare for College Success with:

- Challenging Ivy League Academics
- The Independence of College Life
- Exceptional Students from Around the World

300+ Credit & Non-Credit Course Options

Humanities & Social Sciences

Online Courses

STEM

Leadership Programs

Courses for English Language Learners

On Location Programs

*Also Available:
Sports Camps*



BROWN
Pre-College Programs

www.brown.edu/summer

LIVING LANGUAGE

With the hiring of a former Vatican translator, Cornell has become a hub of an unlikely field in the modern age: spoken Latin

BY BETH SAULNIER

In a classroom on the Arts Quad, two teams of students are facing off in a charged political debate. The subject—whether or not the United States should launch a military intervention against North Korea—is timely, given the increasing tensions between our government and the hermit kingdom’s dictator, Kim Jong-un. But what’s surprising is the idiom in which the conversation unspools: not English—or even Korean—but the language of Horace and Ovid. “*Multi Coreani meridionales morientur*,” one student says, arguing against intervention on the grounds that many South Korean lives would be lost. “*Corea septentrionalis habet plurima arma, et antequam possimus hostes vincere, Corea septentrionalis magnas urbes meridionales crudeliter deleverit*.” Translation: North Korea has more arms, and before we could win, North Korea would cruelly destroy many cities.

The class, held in a windowless room in Lincoln Hall in early November, is one session of a three-credit course—Conversational Latin—whose very title would long have been considered an oxymoron. And its professor, Daniel Gallagher, is one of the University’s more unusual hires: a former Catholic monsignor, he spent a decade working at the Vatican, translating official documents into the language of the Holy See, before leaving the priesthood to get married and start a family. When he joined the Cornell faculty, says colleague Michael Fontaine, “it sort of shook the world of classics.” Gallagher’s hiring, Fontaine says, “is a colossal coup for us. It was an unbelievable alignment of the stars, where an American who is widely regarded as one of the world’s great experts on using Latin as an active, living language decides to give up the priesthood and to accept an appointment with us.”

As classics scholar and Cornell President Emeritus Hunter Rawlings notes, Latin has traditionally been taught on the page: pedagogy was focused on mastering grammar and vocabulary to enable the reading of such ancient texts as Virgil’s *Aeneid* and Ovid’s *Metamorphoses*. “Most of us classicists can’t speak Latin—we can’t speak it at all,” says Rawlings, who first took up the language in the eighth grade. “We were taught to read it, take it apart, and analyze it, not to speak it. So we didn’t use it actively—and that means that people like Dan Gallagher are very rare.” Asked if he has ever chatted in Latin with Gallagher, Rawlings chuckles. “I can’t do it—there’s no way,” he says. “I would be as halting as a first- or second-year student.”

The conversational Latin class, one of several courses Gallagher taught during his first semester on the Hill this past fall, featured activities—like the Korea debate—more familiar to students of modern languages like French, Spanish, and German. He took students on forays around campus to translate the Latin incorporated in maps and artwork; had them haggle with each other in ersatz marketplaces; studied the Latin mottos on state seals; cast them in a mock trial for shoplifting; and more. “I was impressed by the breadth of activities,” says Jason Baretz ’19, a physics major from New Jersey who’s been studying Latin since sophomore year. “My previous classes were more of, ‘Do the homework assignment from the book and translate the sentence and then talk about it in class.’ I found it a nice change of pace that there’s a variety of things we can do in applying the Latin.” ▶

LIFE LESSON (opposite): A fresco in Willard Straight Hall—one of the few examples of Latin on the Cornell campus—bears a famous motto from antiquity: “I regard nothing human as alien to myself.”

PHOTO: JEFF LOWER



HVMANI
NIHIL·A·ME
ALIENVM
PVTO

Gallagher's title is "professor of the practice," a non-tenure-track position less frequently given in humanities than in fields like science, technology, and business. It's intended for faculty who don't necessarily have traditional bona fides—such as a PhD and numerous journal publications—but whose professional experience makes them valuable educators. "This was an innovative way to bring someone to the academy who had this almost unique background but had not previously been an academic," says Provost Michael Kotlikoff, who notes that Cornell's Latin reputation has already risen to the point where students are seeking to transfer from other institutions. "If you are interested in this area and really want to obtain a kind of fluency and comfort with the language, Cornell is the place to come." A February 2017 blog post from the Classical Association of New England called Gallagher's hiring a "game changer . . . [that] has



'WHEN YOU LEARN LATIN,' GALLAGHER SAYS, 'WHOLE WORLDS OPEN UP.'

burst into the world of classics," adding: "This is a major change for an Ivy League classics department, no question, and people active in the Living Latin community are paying close attention."

Gallagher himself came to the language relatively late; he began studying it as an undergrad at the University of Michigan, where he majored in microbiology and graduated in 1993. He didn't fall in love with Latin until he moved to Rome to study philosophy and theology as a seminarian and encountered a legendary Vatican Latinist and teacher who'd long encouraged a more active approach to learning the language. After ordination, he returned to Michigan to serve as a parish priest and teach at a seminary before being tapped to succeed his Latin mentor as a Vatican secretary. "Latin for me has this beautiful music—not just the sound but the feel to it, the way it's constructed, almost like a Beethoven or Mozart symphony," he says. "It's the ending of words that indicates the meaning, not the word order, so when you're speaking or writing you have a lot of freedom on how to arrange words so they sound appealing—but also to syntactically separate words, so your listener has to be patient, like listening for a theme in Beethoven to develop." In addition, he says, "when you learn Latin, whole worlds open up. It can be physics, astronomy, medicine, history, philosophy, theology. You can read Galileo's discovery of the moons of Jupiter in flawless Latin. Basically, the whole of human experience is opened up to you through the lens of a language." ▶

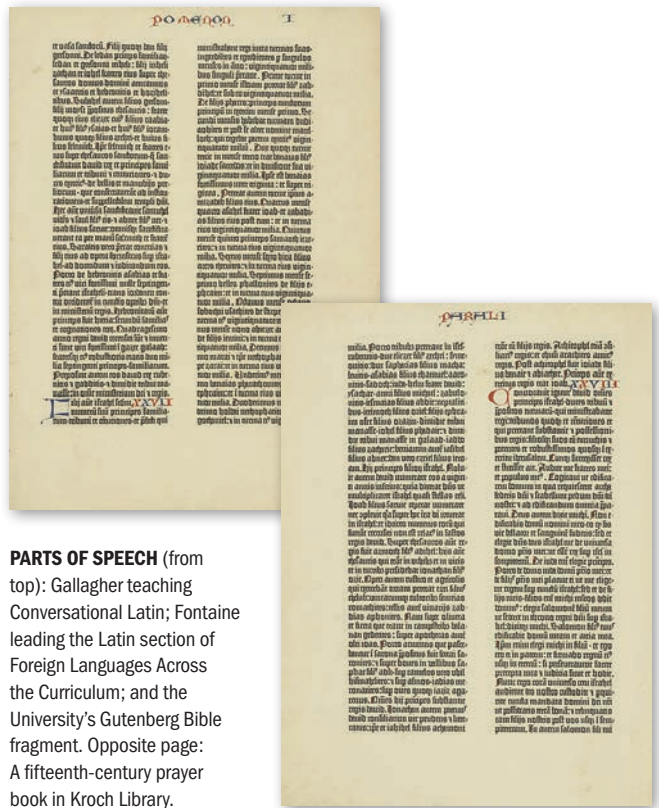

PARTS OF SPEECH (from top): Gallagher teaching Conversational Latin; Fontaine leading the Latin section of Foreign Languages Across the Curriculum; and the University's Gutenberg Bible fragment. Opposite page: A fifteenth-century prayer book in Kroch Library.

PHOTOS: OPPOSITE, JEFF LOWER; THIS PAGE, GALLAGHER, JEFF LOWER; FONTAINE, ROBERT BARKER (UREL); GUTENBERG BIBLE PAGES, RMC

THE TWEET LIFE

TRANSLATING THE POPE'S TWITTER FEED

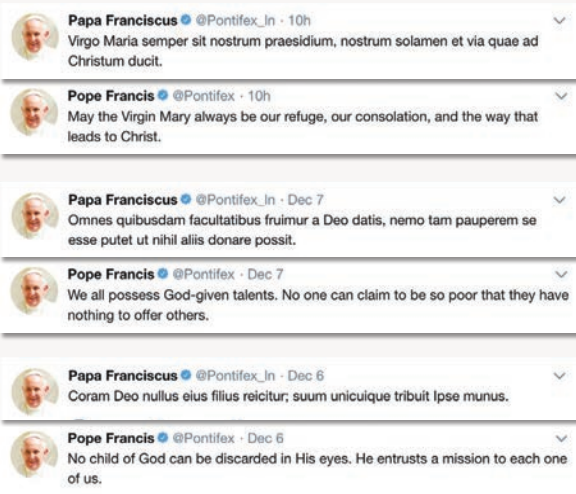

When Gallagher and his Vatican colleagues began translating papal tweets into Latin in early 2013, they had no idea how popular the brief missives would become. The feed gained more than 100,000 followers in its first six months and has since grown to 855,000. As Gallagher notes, even translating the medium's name was a matter of some debate. "Twitter is associated with the sound of a bird, and in Latin there are many words for that, like *pipiare* or *pipilare*, and people who study the classics know some of them, because Catullus uses this kind of language in his poetry," he says. "But it didn't sound right; it didn't have any weight to it." They ultimately settled on *breviloquens* ("to speak briefly"), which references an expression from Cicero. "As a Latin translator, you have to decide: Are you going to translate it literally?" he says. "Or do you want to convey the idea in a way that maybe the ancients could get a sense of it if they were here? And that's what we opted for." Among the most challenging words that Gallagher and his colleagues had to translate in a papal tweet: "sourpuss," which they ultimately rendered as *vultu truci*. "*Trux* is an adjective kind of like 'taunting' or maybe 'frowning,' and *vultus* is your face," he says. "There's no single word for 'sourpuss'—but we thought that described what a sourpuss would look like."

Both Gallagher and Fontaine are proponents of teaching and speaking Latin as a living language, an approach they say is all but unheard of in American colleges and universities—a program at the University of Kentucky being a rare exception—and one that makes Cornell unique in the Ivy League. While both professors are passionate fans of classical texts, they believe that the ability to speak fluently is invaluable—not only offering its own pleasures, but enabling closer and more active understanding of the written word. "This idea of learning Latin through the spoken method is not a gimmick," says Rawlings, who helped recruit Gallagher to the Hill while serving as interim president. "This is to help you learn it well, so that when you read Cicero or Virgil or whomever, you understand it better."

Gallagher came to Cornell from the world's Latin epicenter, the Vatican, where it remains the official language. As one of the Pope's Latin secretaries, Gallagher passed the Sistine Chapel on the way to work every day. He and a half-dozen colleagues were responsible for translating everything from weighty diplomatic tracts to the Pope's Latin Twitter feed. Each afternoon, he recalls, the staff would gather for tea and conversation. "We would talk in Latin about the weather, the soccer game the night before—everything from the World Series to the World Cup—and it could be a real challenge," he says. "To talk about, say, a car accident you were in, you'd have to think hard about the vocabulary. But we forced ourselves to do it, so we could get better, and also to stay speaking in the same language in which we were working."

GALLAGHER CAME TO CORNELL FROM THE WORLD'S LATIN EPICENTER, THE VATICAN, WHERE IT REMAINS THE OFFICIAL LANGUAGE.

For Fontaine, a memorable translation of a modern term came during a summer teaching stint in Rome, when he was called upon to come up with the Latin for "selfie stick." He coined the phrase *ferula narcissiaca*, or "Narcissus stick." "I must say with no humility that it was regarded as fairly ingenious," he says with a laugh. "It went viral all over Twitter." In addition to his teaching, Fontaine regularly consults—*gratis*—with museums who need help translating the Latin in their artworks. Once, he even helped a collector identify a forged painting by pointing out a mistake in a Latin abbreviation. (Among his other sidelines: running a now-defunct website, *latintat.com*, that offered free—and more to the point, accurate—translations for people aiming to get tattooed with Latin sayings.) Rawlings notes that having both Fontaine and Gallagher on the faculty makes the University "especially lucky" when it comes to spoken Latin. "The fact that Cornell has these two professors, and they're young and exuberant, puts it in a unique position," he says. "And that is well known across the country."

Latin has had a role at Cornell since its early days; the entrance exams that nineteenth-century students had to pass to gain admission to the University included a Latin section that often featured not only translations and grammar, but ancient geography, >

HERE'S TRANSLATING YOU, 'KID'

A YOUTH BESTSELLER RENDERED IN LATIN

While still working at the Vatican, Gallagher was tapped for an intriguing side project: translating the mega-selling kids' book *Diary of a Wimpy Kid*. In *Commentarii de Inepto Puero*, Greg Heffley is still having a rough time in middle school, from facing bullies to getting cast as a tree in the school play—but he's doing it all in Latin. The concept wasn't unheard of,



as children's works like *The Wizard of Oz* and *Winnie the Pooh*—even the first two volumes in the *Harry Potter* series—are available in Latin. “The more I read it, I realized two things,” Gallagher says of *Wimpy Kid*. “One, it was a great story—and two, it would actually render into really good Latin.”

The result, published in 2015, went into a second printing within months and landed on Amazon's top ten list of foreign language bestsellers. In one of the editions, Gallagher includes an appendix explaining his choice of translations for certain terms unknown to ancient Romans—from “heavy metal music” (*musica metallica gravis*) to “Big Wheel” (*Trirota Magna*) to “Barbie Dream House” (*Barbarae Aedes Optimae*). “There are a lot of people who started to read it and got frustrated because it was too hard,” admits Gallagher, who launched the book at an event in Italy with author Jeff Kinney. “I knew that was going to be the case, because it's not easy Latin but it's a young person's book. Some of the expressions I used, you'd have to have four or five years of Latin to really get.”



IN TRANSLATION:

Gallagher, during his Vatican days, presenting a Latin copy of *Diary of a Wimpy Kid* to Pope Francis (above). Right: Scenes from the translated book in which the hero's plot to knock another boy, Rowley, off his Big Wheel backfires; when Rowley falls and breaks his arm, the injury makes his popularity soar among the other kids at school.



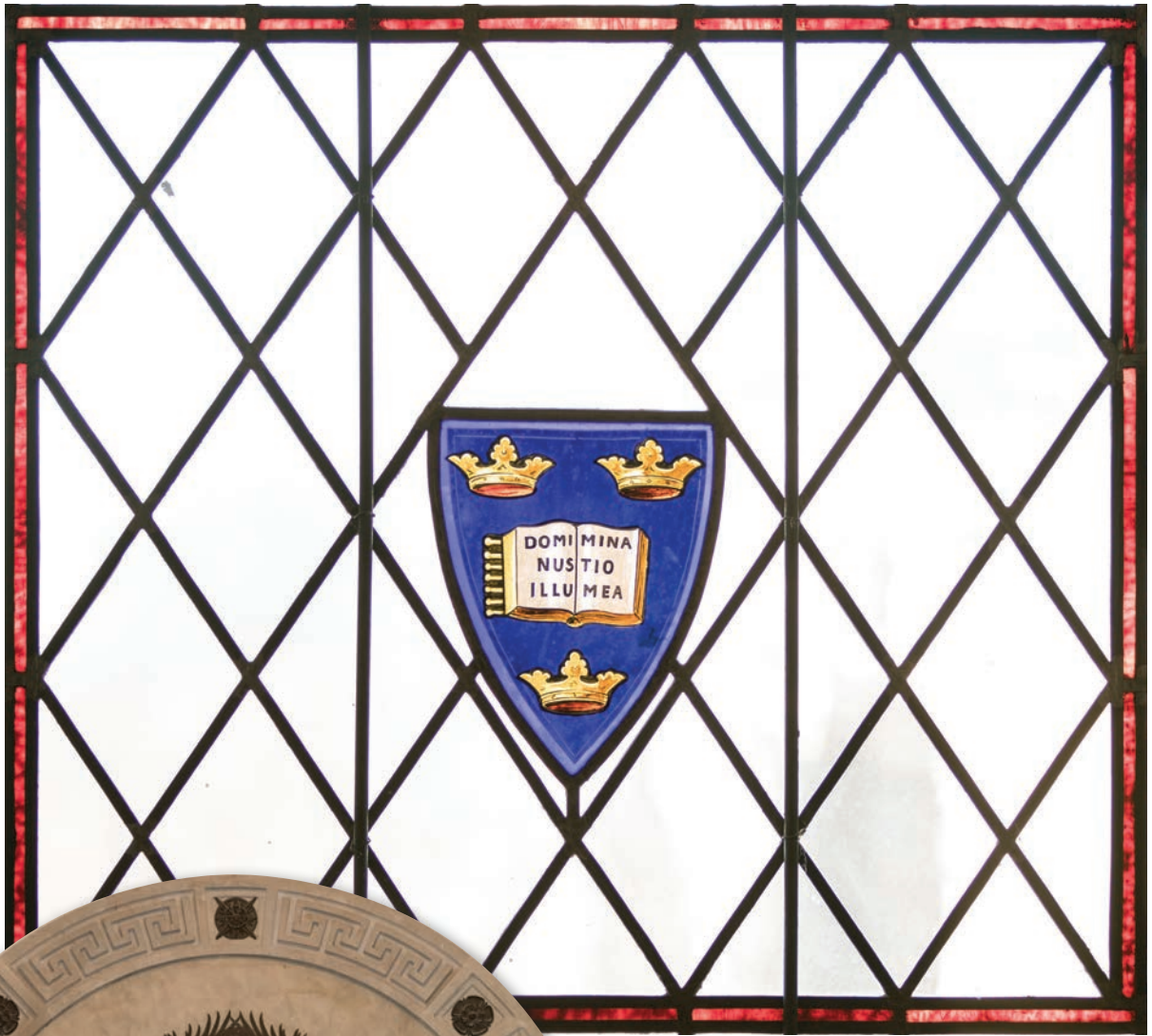

WORDS TO LIVE BY: A window in Uris Library (above) bears the motto, “The Lord is my light.” Opposite page: A stone outside Olin Library says “First among equals.” Left: A plaque in Goldwin Smith Hall offers a paean to its namesake. It reads: “This magnificent building, built to house courses in the humanities, and in which the honoree himself is still an professor ex officio, has been dedicated in honor of Goldwin Smith, a gentleman very well versed in all the arts that pertain to the human condition / Whose writings about matters human and divine, about the past and the present, about the joy of literature and the hopes afforded by religion, are universally admired / Who, amid the ravages of the American Civil War, was a fierce abolitionist and a staunch defender of the integrity of this country / Who has constantly supported this university, which was established by his advice and efforts, with the greatest care / Who by his name, as professor of history, has brought this university great accolades and glory / Who by his own example deeply inspired students to study the liberal arts / And, lastly, who, by his life and character fostered love, charity, and devotion among everyone associated with this university.”

PHOTOS: JEFF LOWEY

Roman history, and more. (From the 1878 test: “When did the Lupercalian and Saturnalian festivities occur? Upon what modern observances have they probably been grafted?”) But as Fontaine notes, the campus itself contains only a smattering of Latin inscriptions, including a brief one in the lobby of Willard Straight Hall and a longer dedication to Goldwin Smith in his namesake building. “This tells you something about Cornell,” he says. “Every other Ivy is loaded with Latin inscriptions, because they were Bible colleges—and Catholics, Protestants, and Anglicans all used Latin as the basis of their scripture. But Cornell was founded as a secular, co-educational, ‘any person, any subject’ place from the get-go, so it doesn’t participate in the Latin tradition. The absence of Latin shows you Cornell’s commitment to secular education from the beginning.”

The University’s outward lack of Latin notwithstanding, it has—particularly with Gallagher’s arrival—become a lively locus of Latin scholarship. Andrew Hicks, a Medieval Latinist on campus, says the level of student interest is unprecedented in his seven years on the Hill. “It’s an extremely exciting time to be studying Latin at Cornell,” says Hicks, an associate professor of medieval studies, music, and religious studies. “It really has become kind of a self-driving, self-sustaining culture. There’s a new sense of urgency and value that comes from the students themselves.”

Fontaine says that after a dip in Latin enrollment during the economic downturn—when students may have felt increased pressure to pursue courses with more clear prospects for future employment—it has rebounded. According to figures from the classics department, more than 120 undergrads and grad students took Latin classes in fall 2017; in some semesters earlier in the decade, numbers had dropped as low as the sixties. “What has really come back with a vengeance is the enthusiasm,” says Fontaine, who is Cornell’s associate vice provost as well as a professor of classics. “The students are gung-ho about really learning it well. They’re especially interested in learning it as an active language, because it seems less like a code you have to crack and more like a language people actually use to talk to each other. Some of that is coming up from the high schools, because in the past ten years a revolution in pedagogy has been slowly growing, so we’re now getting e-mails from prospective students who know we’re trying to do this here.”

Fall 2017 saw the founding of the *Sodalitium Loquentium Latine*, a student-run Latin club that meets weekly in Stimson Hall’s Language Resource Center. The group, led by Nicole Marroquin ’19, offers such activities as playing games, composing poetry, and watching movies—all in Latin. “Some of my friends don’t understand why I would like a ‘dead’ language; they haven’t taken Latin and they don’t know the joy of reading exciting stories and learning about the history and culture of the time,” says Marroquin, a fluent French speaker who matriculated into the Engineering college but transferred to Arts & Sciences, where she’s double majoring in classics and in chemistry and chemical biology. “I hope the club will help strengthen students’ oral skills in Latin, because I think it’s tremendously helpful in translating and understanding the language. It might sound a bit cliché, but I think it brings it to life.”

For a decade starting in the mid-Aughts, Fontaine organized a similar effort, leading weekly Latin chats over pizza in



THE CAMPUS CONTAINS ONLY A SMATTERING OF LATIN INSCRIPTIONS—WHICH, FONTAINE SAYS, ‘SHOWS YOU CORNELL’S COMMITMENT TO SECULAR EDUCATION FROM THE BEGINNING.’

Collegetown (first at the Chariot, then at the Nines) that would draw as many as a dozen and a half students. “The twenty-one-year olds would maybe get a pitcher of beer, because a little booze can free up the tongue,” Fontaine says with a laugh. “In fact, in the *Odyssey*, Homer says you’re less inhibited about public speaking if you’ve had a couple of drinks.” (Asked if the group raised eyebrows by conversing in Latin over pepperoni, Fontaine says, “I don’t think anyone ever regarded it as any stranger than anything else you’d see in Ithaca.”) Fontaine has also taught the Latin section of Cornell’s Foreign Languages Across the Curriculum (FLAC) program; a relatively new offering, it lets students earn one credit hour by meeting weekly to discuss topics related to an existing course—be it on history or politics or music—in a foreign language. The Latin FLAC that he led in fall 2016, he says, was one of the most popular in terms of student enrollment, behind only Spanish.

Both Fontaine and Gallagher are on the advisory board of the Paideia Institute, an organization devoted to the study of classical languages, and have taught in its summer program in Rome. Paideia has helped fuel a small, worldwide resurgence of interest in Latin, and counts numerous Cornell students among its alumni. “They had this uninhibited passion to speak Latin,” Gallagher says of the Cornellians he taught in Rome before coming to Ithaca. “I don’t know how to explain it, but I see it now that I’m here. They are fearless. They’re not embarrassed to come in and sound like babbling babies at the beginning. They’re very, very excited.” When it comes to Latin, he says, “Cornell is a very special place now. They’re aren’t many schools—Ivy League or not—that would be willing to give this a try.” ■



AN 'UNFILTERED'

VOICE

On her HLN round-table show, journalist S.E. Cupp '00 offers a conservative take on the news—but shouters need not apply

BY HEATHER SALERNO

It's just minutes before her prime time cable news show goes live at 7 p.m., and conservative commentator S.E. Cupp '00 is in a Manhattan studio on a Thursday in October, camera-ready and cracking jokes. "It's finally leather weather!" she laughs, adjusting her black leather skirt. But she's immediately all business at a cue from a producer—jumping into a remote interview with Oklahoma Senator James Inhofe, who's in Washington, D.C., about a surprise attack in Niger that killed four American soldiers. It's been a hot topic on "S.E. Cupp Unfiltered"—which premiered in August on HLN, CNN's sister network—with Cupp wondering why so much focus has been on President Trump's remarks to one soldier's widow, rather than on a lack of information from the Pentagon about the deadly ambush. Cupp wants answers—and she assumes Inhofe, a fellow Republican and senior member of the Armed Services Committee, wants some, too. Yet the interview doesn't go as expected. When Cupp asks him for "the most pressing questions" about

the attack, Inhofe responds, "Well, what questions are unanswered?" She pushes the senator further, asking if the attack was due to "an intelligence failure." Inhofe again doesn't answer directly, saying there's risk anywhere troops are on the ground.

Cupp's allotted time with Inhofe ends, and she sits back in her chair. There's a long pause before she gets a signal that she's no longer on camera—and then she explodes with amusement. "What the—?" she says in a singsong voice, ending the sentence with an expletive. "That was bizarre. I can't wait to watch this interview back—it's going to be painful!"

And with that, Cupp shakes off the exchange and smoothly moves on to the next segment; she's a TV veteran, and it takes more than one awkward conversation to fluster her. The right-leaning host has spent years dealing with unpredictable politicians and outspoken pundits as a frequent contributor on CNN, MSNBC, and Fox News and programs like "Real Time with Bill Maher" and "The View" and as a writer for the *New York*

PHOTO: CNN



LIVE FROM CLEVELAND: Cupp (second from right) on a CNN panel during the 2016 Republican National Convention. Below: Shaking hands with Donald Trump at a GOP candidates' debate. Opposite page: On the set of her HLN show.

Daily News, *Glamour*, and CNN.com. She has built a reputation as someone who isn't afraid to speak her mind—and these days, she's calling the shots with her own program. Cupp points out that during this particular week, she insisted on long pieces about the Niger situation. "Foreign policy usually makes people change the channel, and I know that," she says. "But I feel like it's my job, my responsibility, to share the stories that matter with as many people as possible—and this matters. That's a gift."

About two hours earlier, Cupp is in her office two floors below the studio, ending a meeting with producers. It's been a full day already, beginning with a 10 a.m. conference call as she commuted from the suburban Connecticut home she shares with her husband and three-year-old son. At the moment, she's in casual wear, with a camouflage scarf layered over a gray T-shirt and snakeskin print leggings, hair in a messy bun, and her trademark glasses in place (yes, they're real). She notes



that there's one big way "Unfiltered" stands out in the contentious world of cable news: it's a no-yelling zone. "The people I invite on the show I truly admire, respect, and want to hear more from," says Cupp, whom *New York* magazine's pop culture website *vulture.com* has called one of TV's smartest pundits. "Whatever we're talking about, we try to do it civilly and quietly. We are passionate and emotional about everything we talk about, but the audience can hear us articulate our points. No one is shouted off." Cupp says she doesn't automatically see someone with a different opinion as an enemy, and she tries to book guests each night that offer a range of views. It's something she appreciated co-hosting CNN's re-launch of "Crossfire" from 2013 to 2014, where she often found common ground with colleagues like Van Jones, a former special adviser in the Obama Administration. "A lot of people like to tune in to shows that reaffirm their beliefs and to see someone be as angry as they are; I get that," she says. "But I'm over that, and I have to think that other people are over that, too."

Still, Cupp is vocal when it comes to being a conservative, even if her thinking sometimes doesn't align with so-called conservative values. She grew up Roman Catholic, but is now an atheist. She backs gay marriage and opposes the death penalty, yet she's pro-life and supports gun rights. And while she's a proud Republican, Cupp won't uniformly toe the party line—calling out the GOP on the air, for instance, for not being as outraged by the Niger ambush as they were

about the 2012 Benghazi attack. "I'm very open when I have some criticism for the party or the president. I'm also not totally defined by formal conservatism," she says. "I talk about these issues from a place of common sense. I hope people find that to be accessible and refreshing." Yet that means both the left and right have slammed her at times. When *Esquire* political blogger Charles Pierce disagreed with her comments on President Obama's tax policy, he called her "a colossal idiot." Several years ago, after Cupp criticized Planned Parenthood, former MSNBC and ESPN commentator Keith Olbermann '79 tweeted that she was "a perfect demonstration of the necessity of the work Planned Parenthood does," sparking controversy when some thought he was implying that she should have been aborted—or at least, that she should never have been born. And during the presidential election, Cupp's open disapproval of Donald Trump kicked off a Twitter attack. "One of the dumber pundits on T.V. Hard to watch, zero talent!" he wrote, later adding that she was "a totally biased loser who doesn't have a clue."

Cupp shrugs off the criticism and points to a photo on her desk of Trump shaking her hand last year following the presidential debate in Miami. She's known him for years; both have appeared on Fox News, and she's friendly with his son Donald Jr. She even lived in one of his New York

apartment buildings at one time. (He sent her a monogrammed cutting board as a housewarming gift.) So Cupp kept an open mind when the real estate mogul first announced his candidacy. However, she says it soon became clear that his views didn't align with hers or those of some other

'A lot of people like to tune in to shows that reaffirm their beliefs and to see someone be as angry as they are,' Cupp says. 'I get that. But I'm over that.'

Republicans. "I think he's divisive and the opposite of a leader. But my personality issues with him aside, I don't think he's a real conservative. I don't think he knows what conservatism is, and he doesn't have a lot of undergirding principles," >



PHOTO: CNN



DEBATE CLUB:

Cupp (second from left) on HBO's "Real Time with Bill Maher" with (from left) Ron Reagan, John Cleese, Bill Maher '78, Jane Goodall, and Spike Feresten.

she says. "I've said that I thought he wore the party like a rented tuxedo to get through the election. He doesn't care about the party. This is not 'a shining city on a hill.' This is not Reagan. This is the basest worst of us. So we're kind of keeping our head down, doing the hard work, and waiting for this to be over."

But when it comes to her HLN show, Cupp knows that her viewers are interested in more than Trump—and she is, too. So she always finds room for compelling human-interest stories or odd news of the week; her panel on this day discusses the fact that shops in Hawaii are locking up Spam because people are stealing the popular canned meat to sell on the black market. She's also interviewed several of TV's "Real Housewives" and says her dream guest would be Andy Cohen, an executive producer of the "Housewives" franchise and host of Bravo's late-night talk show "Watch What Happens Live." "I'm not only about politics," says Cupp, "and I don't think most other people are either."

Growing up in Andover, Massachusetts, a young S.E. (for Sarah Elizabeth) trained seriously with the Boston Ballet company and planned to dance professionally. But she burned out at seventeen—she has written in the past about her battle with eating disorders that began in ballet

school—and changed direction. At Cornell, she thrived as an art history major and at the *Daily Sun*, where she was an arts and entertainment writer and editor. "She wrote wonderfully articulate, intelligent, sensitive reviews of exhibitions,"

Cupp describes her time at Cornell as 'a wake-up call,' and she can still remember the exact moment that prompted her to question her beliefs.

says Johnson Museum of Art director emeritus Frank Robinson, who asked her to join the museum's advisory council after graduation. "She really understood the role of art, and the role of the museum as part of the educational mission of Cornell." In fact, Cupp is such a fan of abstract painter Wassily Kandinsky, she has a tattoo of

PHOTO: PROVIDED

the artist's signature on her lower leg. "It's like he signed me," she says, pulling up her leggings to show it off.

Cupp describes her time at Cornell as "a wake-up call," and she can still remember the exact moment that prompted her to question her beliefs: at a debate on affirmative action during her freshman year, where she found herself agreeing with Jeremy Rabkin '74, then a government professor and a prominent conservative voice on campus. "I walked in thinking I'm a liberal, because liberals are good people and conservatives are bad people—at least from what I saw in the movies," she says. "I was so horrified that I was agreeing with Professor Rabkin's points. He made them very logically. He wasn't angry. He wasn't racist. He just said, 'This is not good and here's why.' That really got my attention and I thought I needed to learn more. I literally went on a fact-finding mission to figure out what I believed politically, and it led me very clearly down one road." She questioned her faith, too, even though she says that the devout have always fascinated her—an interest that later motivated her to earn a master's degree in religious studies from NYU. "I always say I don't believe in God, but I aspire to be a believer one day," says Cupp. "I'm really envious of deeply religious and spiritual people. I've spent a lot of time trying to get there mentally. I just never could."

After leaving the Hill, Cupp worked at the *New York Times*, wrote for publications like the *Washington Post*, *Slate*, and *Maxim*, penned two



books (*Losing Our Religion: The Liberal Media's Attack on Christianity and Why You're Wrong About the Right: Behind the Myths—The Surprising Truth About Conservatives*), and

served as a consultant for HBO's journalism drama "The Newsroom." She first broke out on cable TV at Fox News, and joined MSNBC in 2012 to co-host "The Cycle," an ensemble talk show on news and politics. Cupp then moved to CNN to co-host "Crossfire" and later launched "S.E. Cupp's Outside With Insiders," a series on CNN.com in which she interviewed influential politicians while hunting, shooting, or fishing. The show caught the attention of HLN's chief executive, who helped develop "Unfiltered." As someone who's followed Cupp's career for nearly two decades, Robinson says that he's impressed by her smarts and how she approaches complicated issues. "I'm a Democrat and she's obviously not, but I really respect her opinions," he says. "They're cogent, balanced opinions that actually make me rethink my own. I think if there were more people in the political conversation like her, we might be able to build a consensus in this country—which we don't have right now—and move things forward."

Cupp is also concerned that the U.S. isn't moving forward, especially given the current political climate; while she's a fan of vigorous debate, she thinks this country's leaders need to tamp down on the vitriol if they're going to work together to solve problems. And while she's not shy about offering her opinions on how to do so, Cupp has no plans to run for office herself. "I'd be awful at it," she says, before racing away, since she's late to get her makeup done for broadcast. "I'd rather just be here, unfiltered," she adds with a laugh, "and not have to keep my mouth shut." ■

STUDENT DAYS:

Cupp (top, at center) with former *Daily Sun* colleagues Matt Laffin '00 (left) and Farhad Manjoo '00 and in the *Cornellian* (above). Below: Competing on "Jeopardy!" in May 2016.



PHOTOS: LEFT, JEOPARDY!; TOP, LEFT, PROVIDED; TOP RIGHT, 2000 CORNELLIAN

BY THE

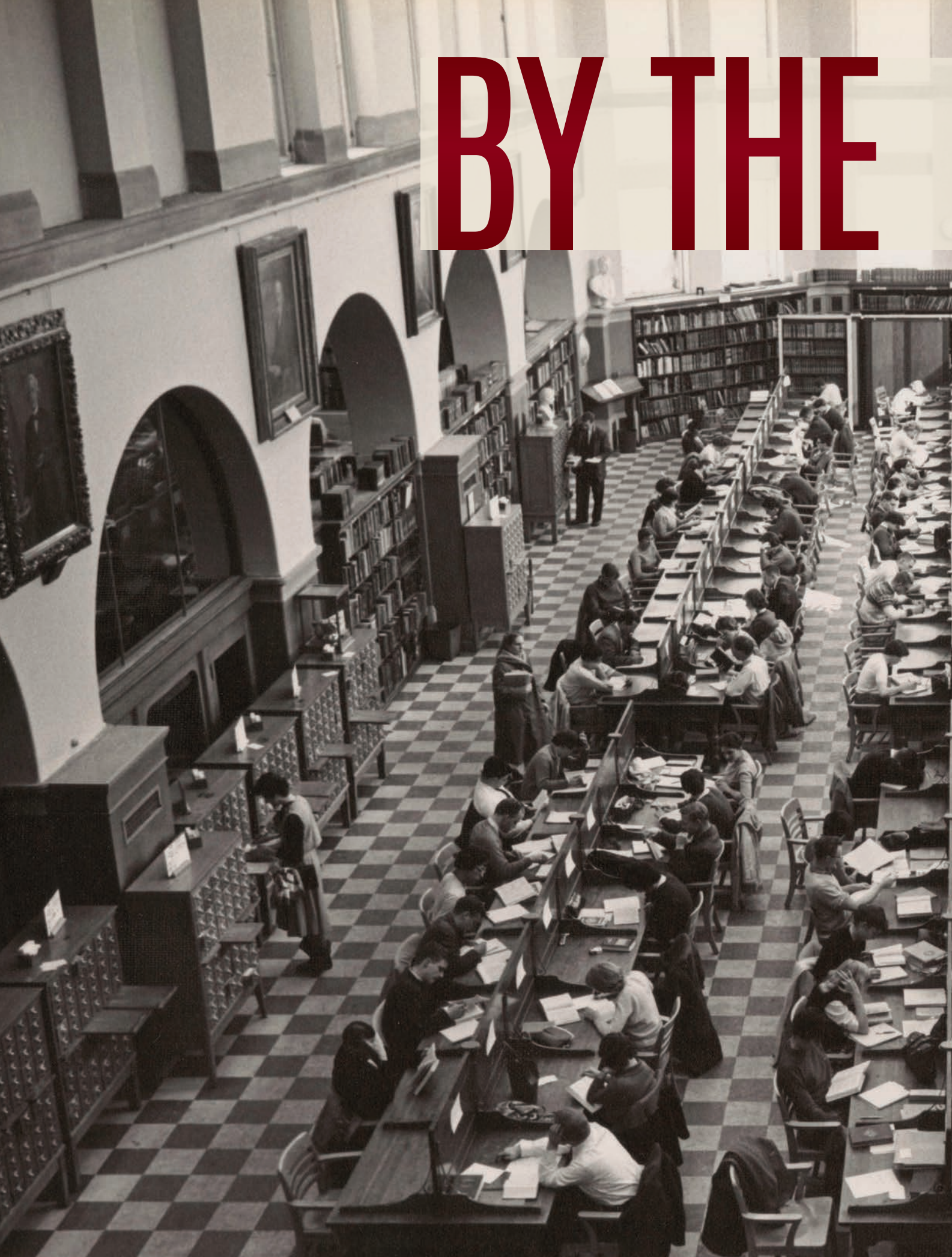

BOOKS

Long the hub of campus scholarship, Cornell's libraries are as lively as ever

BY ALEXANDRA BOND '12



STUDY HALL: A packed Uris Library reading room in 1960



Once upon a time, Cornell's card catalogue was king. In the pre-Internet era, those wooden drawers were the repository of knowledge about the University's library holdings—and such a precious resource that Olin Library's staff was instructed that in an emergency, they should save the catalogue even before the rare books. During the Sixties era of political unrest—when it was feared that the catalogue might be vandalized—library staff microfilmed every card.

Today, the card catalogue is long gone, and the University Library's holdings are searchable online from anywhere in the world. And just as campus libraries have evolved, so have the ways in which students use them. While the digital revolution could have made such brick-and-mortar facilities as obsolete as index cards, the opposite has happened: at Cornell, the libraries are as essential as ever, and arguably even more lively. Olin—once, as former University Librarian Anne Kenney puts it, a “sleepy enclave” reserved for faculty and graduate students—is now the single busiest building on campus, and the library



Libraries, says former University Librarian Anne Kenney, “invite and celebrate human interaction in this age of virtual worlds and disconnection.”

system overall sees upwards of four million visits a year. Long seen as vaunted spaces for quiet contemplation and scholarship, libraries have taken on a broader role, becoming vibrant hubs for socializing, collaborating, and more. “Libraries offer ways to break down isolating barriers to engage with others,” says Kenney, who came to Cornell in 1987 and led its library system from 2008 to 2017. “They invite and celebrate human interaction in this age of virtual worlds and disconnection.”

Kenney's successor, Gerald Beasley, came to the Hill in August 2017 after previous posts at Columbia, the University of Alberta, and Concordia University. He likes to say that students think of libraries in two contrasting ways: as “cathedrals”—meaning that they want to be awed by the majesty of a temple of scholarship—and as “gas stations,” where they can quickly access the resources they need. He embraces this paradox, aiming to >



MORALE BOOSTERS (from top): A llama visiting the Law Library during a pet therapy session to lower pre-exam stress in spring 2012; students working and relaxing in Olin's popular Libe Café; and a soothing installation of grass in Mann in fall 2011, designed to promote (as its signage explained) “the restorative benefits of nature.” Opposite page: Students at work in Mann.

photos: previous spread, cornell library; are and manuscript collection, opposite, top: lindsay France (ur el); Bottom: Jason Koski (ur el); this page, From top: lindsay France (ur el); nicola Kountoupes (ur el); mar K vor reuter (che)



‘I want students to feel like they can come to the library for all kinds of reasons,’ says Gerald Beasley, Cornell’s new University Librarian.

provide both types of experiences. “I want students to feel like they can come to the library for all kinds of reasons,” says the Oxford-educated Beasley. “There will be a time when they’re achieving their academic outcomes and that’s great, but there will be another time when they just want to get together with friends and have a coffee.”

Cornell’s twenty libraries boast a combined collection of more than 8 million volumes, encompassing a nearly endless range of fields, from astronomy to the classics, viticulture to Southeast Asian studies. The holdings of the Division of Rare and Manuscript Collections include curated materials chronicling such subjects as human sexuality, hip-hop music, Icelandic history, and witchcraft—not to mention one of five surviving copies of Lincoln’s Gettysburg Address. And online resources are expanding rapidly. Cornell has participated in several ongoing projects to make books available online, scanning more than half a million volumes, and it hosts dozens of digital-only collections. To help students and faculty get the most out of these vast resources—in addition to the services of reference librarians—the libraries host regular workshops and tutorials. “The problem is not the volume of information, because there’s an overabundance of it,” says Beasley. “It’s the quality of that information >

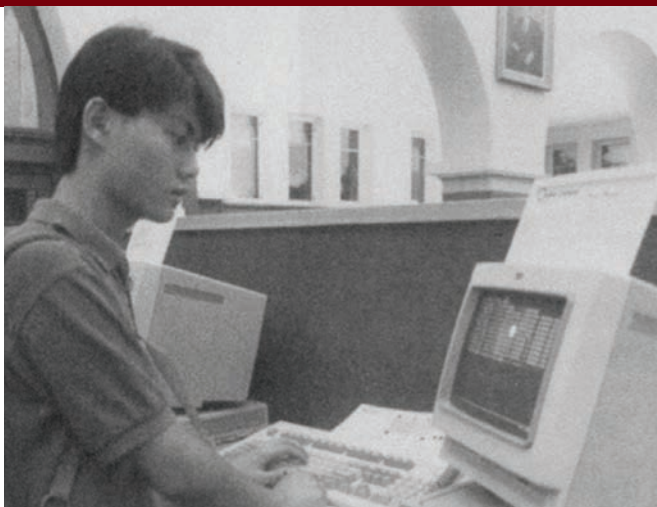

RETRO TECH (clockwise from left): Accessing the online catalogue on a bulky computer in the Eighties, using a microfilm machine in the Sixties, and perusing the card catalogue in the Fifties.

photos, top, university archives; Bottom, Alumni news; opposite e.r.mc







and the ability to assess and analyze it. That, you still need to come to the library for.”

The fact is that Cornell’s libraries have never stayed the same for long. There was a time when allowing students to check out books was unheard of; it wasn’t until almost a decade into the twentieth century that materials began to circulate. By 1872, the University Library, then located in McGraw Hall, was open for a whopping nine hours a day—longer than any other library in the country at the time. When electric lights were installed in 1885, it could finally remain open after dark. “The number of readers in the evening has not been large,” Cornell’s then-president Charles Kendall Adams noted in his annual report, “but it has been sufficient to encourage the Library Council in regarding the experiment as successful.”

Now, many libraries on campus are open into the wee hours of the morning—some even twenty-four hours a day. And while alums from earlier decades might be shocked to hear that today’s students can eat and drink in the stacks, current Cornellians would be equally surprised to learn that smoking was once allowed in certain library spaces. The introduction of cafés in several libraries was met with outrage from some who feared materials would be damaged by spills >

There was a time when allowing students to check out books was unheard of; it wasn’t until almost a decade into the twentieth century that materials began to circulate.



READING INTO IT: Scenes from (opposite page) Uris’s A.D. White Reading Room, and (this page) Mann Library

photos: opposite, © Bert Bar Ker (ur ei); Top, mat th ayes (cal s); Bot tom, Lindsay France (ur ei)



Last fall, Mann opened Cornell's first 'makerspace,' an area dedicated to building and creating anything from a podcast to a poster to a scarf.



and stains—but they're now among the most popular destinations on campus.

Elaine Engst, MA '72, the University's archivist emerita, notes that the system has been crunched for space "from almost the very beginning." Back in the Fifties, excess books had to be stored in the Clock Tower—eventually spurring construction of the Library Annex, located at the edge of campus near the apple orchards. In recent years, to free up space for computer stations, additional study areas, and other resources, many of the less-frequently circulated books have been moved to the annex and can be recalled through the library's online system. "Libraries evolve with the times," says Kerry Mullins '18, an agricultural science major who has been a student employee at Mann for three years. "That's why they're staying relevant."

On the Hill, the individual libraries reflect the varied interests of the students they serve. (As Beasley observes: "Students will find the perfect spot for themselves in a library that might have nothing to do with what they're studying.") Uris, for example, remains filled with physical books and is popular for students seeking a quiet nook. Across campus, Mann Library—affectionately dubbed "Club Mann"—is known for its social and bustling atmosphere. Libraries like Engineering and Physical Sciences, which house their entire collections online or off-site, provide students with reference librarians and spaces for solo or collaborative study. "When you walk into a library, the distractions of your apartment and other places on campus aren't there," says Mullins. "For a study space alone, it's vital."

Last fall, Mann opened Cornell's first "makerspace," an area dedicated to building and creating anything from a podcast to a poster to a scarf. Dubbed "mannUfactory," it offers such high- and low-tech tools as a large-format printer, a button maker, a virtual reality room, a T-shirt press, hammers and screwdrivers, computers loaded with prototyping software, sound and recording equipment, 3D printers, knitting needles and yarn, sewing machines, and even Legos. While many of these tools are already available on campus, they're often affiliated with particular departments, and students need permission to use them. In the new facility, all Cornellians can utilize the space, attend workshops, or get one-on-one tutoring in how to use the gear. "People tend to focus on the equipment with makerspaces, but what's really important is the community," says Camille Andrews, one of the Mann librarians heading the project. "The idea is bringing people together to work on things, to play, to experiment, to learn from failure, and to innovate."

During exam weeks, the libraries have been known to go above and beyond to provide some TLC to stressed-out students, offering amenities like free snacks, coffee, and ice cream in the lobby. On several occasions, sections of live grass lawn have been installed, on the principle that contact with nature would boost morale and promote relaxation. Therapy dogs sometimes visit; a llama has even been stationed in the Law Library lounge. "Libraries understand that their role extends beyond being knowledge repositories," says Associate University Librarian Oya Rieger, PhD '10. "They are a part of creating a nurturing community." ■

BE ORIGINAL: The new "mannUfactory" fosters a wide variety of creative pursuits, including making buttons (left) and using virtual reality technology (top).

EZRA

CORNELL
UNIVERSITY'S
MAGAZINE
EXTRA

This special section, a bonus issue of the university's Ezra magazine, highlights ways Cornell initiatives intersect with philanthropy and engagement of Cornell alumni, parents and friends.

DR. AUGUSTINE M. K. CHOI ON COLLABORATION, CLINICAL CARE AND CONSENSUS BUILDING

Dr. Augustine M.K. Choi has served as the Stephen and Suzanne Weiss Dean of Weill Cornell Medicine and Cornell University's provost for medical affairs since January 2017. The full conversation is available at news.cornell.edu/ChoiQA.

You came here from Harvard in 2013 to lead the Weill Department of Medicine. What drew you to WCM?

I was directing the pulmonary and critical care division at Brigham and Women's Hospital [in Boston]. The Weill Department of Medicine at Weill Cornell Medicine and NewYork-Presbyterian/Weill Cornell Medical Center encompasses 16 divisions – hematology and medical oncology, gastroenterology, cardiology, and more – so the opportunity to have a greater impact on a more diverse group of faculty was a big draw. In this era of declining National Institutes of Health funds and reduced reimbursements for patient care, many medical schools and departments of medicine are not growing; at Weill Cornell it has been quite the contrary. We have a tremendous amount of energy and growth in our community.

continued on next page



Tavis Curry

“... AS YOU DEVELOP THROUGHOUT YOUR CAREER, YOU LEARN FROM YOUR TEACHERS, YOUR MENTORS, AND YOU CREATE YOUR OWN KIND OF PHILOSOPHY OF LEADERSHIP.”

What in your personal and professional background contributes to your leadership style?

I think my parents had a lot to do with this. They were role models and supported me throughout my studies and into my career. Since my dad was a physician and scientist himself, he and I could especially relate. And as you develop throughout your career, you learn from your teachers, your mentors, and you create your own kind of philosophy of leadership. I’ve always considered several tenets to be essential. One is consensus-building among your faculty, your students and your trainees. I think that’s important because on 15 out of 100 things, people don’t agree. So when you try to resolve those issues you need consensus-building. Two is transparency. Number three is caring. To be an effective leader, you care, you’re open and transparent, and you’re willing to work together to build consensus on issues where perhaps there’s not agreement.

You’ve said the educational system was a factor in drawing your parents to the United States after the Korean War. Do you think its promise still holds true today?

Absolutely – if you look at the 30-odd years I’ve been here, there are many areas in which the United States has fallen behind, whether it’s economics or the steel industry, but there’s one area where we still are second to none, which is higher education. The U.S. university system is the best in the world. The rigor and the quality are very consistent, and these are values we cannot lose. This is why I’m very passionate about the evolving policy on immigration, because part of the success of our university system has been our country’s very open policy for students from all over the world to come here for higher learning.

Supporting immigration to the U.S. is a win-win – we’re contributing to the well-being of the global community plus adding to our strengths here. We are the most diverse country in the world, and that’s one of our major strengths.

How does diversity benefit patient care, discoveries and education of future doctors?

Diversity positively impacts all of these areas. It promotes new and exciting ideas in the classroom and in the lab that are born of a wide range of experiences and histories, and these varied perspectives lead to new ways of delivering health care that benefits everyone.

At WCM, our enthusiasm for diversity enables us to attract the best minds in science and the most promising future doctors from all over the world. Having a range of perspectives in the lab and in the classroom challenges us to think innovatively, to collaborate, and raises the bar for what we can achieve together.

At the clinical end, diversity enhances the care we provide because it recognizes two key things: Gender and ethnicity affect not only the risk of disease, but the response to therapies and many other ways patients experience health and illness. Quite simply, it makes us more effective and compassionate physicians.

Tell us what role the faculty plays in mentoring trainees as well as junior faculty.

To truly fulfill their greatest potential, to navigate the next critical years as they pursue faculty status, they need mentors. We all need these relationships as we grow, and as we progress in our careers, it becomes our lifelong responsibility to nurture them and become mentors in our turn. In addition to mentoring being the right thing to do, it makes us more competitive as an institution.

How can alumni mentor Weill Cornell students and recent graduates?

Our alumni contribute quite a bit to our scholarship programs. But I would like to involve them more as we work to make mentoring more of an institutional priority, one that is just as important as our three missions of patient care, research and education. Our alumni association has a program in the works that will make it easier to become a mentor to recent medical school graduates.

300+

Number of doctors trained in the Middle East by Weill Cornell Medicine-Qatar.

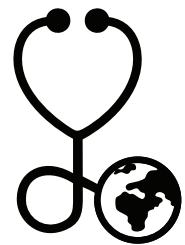

“... our enthusiasm for diversity enables us to attract the best minds in science and the most promising future doctors from all over the world.”

How is WCM collaborating with Cornell Tech as well as with the Ithaca campus?

Precision medicine is one of the most innovative ways clinical care is changing, and to provide it effectively you need big data, patient genomic data. Acquiring that is easy now with the technology that we have at WCM, but the difficulty is analyzing that genomic information. This is where we can collaborate with the Ithaca campus and Cornell Tech, which are very strong in computing and machine learning. We are already collaborating with the Samuel Curtis Johnson Graduate School of Management on an executive MBA/M.S. in health care leadership; the Johnson School is strong in fostering the development of entrepreneurship in the life sciences, and we have a large portfolio of life sciences and health care research they can, in turn, benefit from.

What is the NIH's role in promoting the advancement of research in the current climate?

For the first time, we've had a very sustained period over more than a decade in which the NIH is setting increasingly competitive cutoff points in deciding which grants to fund. We are at risk of losing a generation of innovative, creative scientific minds because of these funding uncertainties.

The good news is that it looks like the budget for next year will not be reduced, but we need to continue our advocacy activities and inform our congressional leaders that NIH funding must at least be maintained or even increased. We also need to be prepared for unexpected changes in the funding climate, so we have to find other resources, whether they're in the private sector, foundations or philanthropy. We are very proactive about pursuing alliances with pharma and building a culture of entrepreneurship to help support our research mission.

Why is Weill Cornell Medicine-Qatar important?

We're committed to providing the best quality of health care to our patients in New York and throughout the region and the nation, but we'd also like to have an impact on public health and research globally.

After 16 years, we're very proud of the impact that we've had: We have uplifted the quality of health care in that area of the Middle East and trained more than 300 doctors. Many of those doctors completed residencies at top hospitals in the U.S., and now they're going back to their homelands in the [Persian] Gulf. Some became faculty members at Weill Cornell Medicine-Qatar.

How is WCM promoting health in Haiti and Tanzania?

Our programs in Haiti and Tanzania are two of our biggest and most long-standing global health initiatives. Faculty members Dr. Jean



Travis Curry

Pape in Haiti and Dr. Robert Peck and Dr. Jennifer Downs in Tanzania live in those countries to build sustained relationships, and many WCM students spend time there. When I talk to our chairman emeritus, Sandy Weill, we always agree on the importance of our role in improving health care overseas. In Tanzania, Sandy committed resources to support the Weill Bugando University College of Health Sciences. A key part of the mission there is to train local physicians who provide health care and do research. In Haiti, we have a close affiliation with the GHESKIO clinic, which has led research on HIV/AIDS in the Caribbean since the start of the epidemic and has been critical for Haitians during natural disasters. We're very proud of those two major initiatives.

What role does Weill Cornell Medicine ultimately need to play in today's society?

At the end of the day, for the good of humanity, we all have to play a part in maintaining dignity and respect in our society. And our role is certainly focused on education, training, and making discoveries and positive impacts on clinical care. We are in the unique and honorable position of contributing to individual lives in lasting ways that can lead to positive ripple effects for the wider community. It's exciting and humbling to be part of Weill Cornell Medicine and an institution that can have such far-reaching impact.

Opposite page: Dr. Augustine M.K. Choi, the Stephen and Suzanne Weiss Dean of Weill Cornell Medicine and Cornell's provost for medical affairs, and Dr. Barbara Hempstead, left, senior associate dean for education, celebrate with fourth-year medical student Cindy Parra, right, during national Match Day March 17, 2017.
Above: Dr. Augustine M.K. Choi, center, poses with first-year Weill Cornell Medicine students during their White Coat Ceremony Aug. 15, 2017.

“GENDER AND ETHNICITY AFFECT NOT ONLY THE RISK OF DISEASE, BUT THE RESPONSE TO THERAPIES AND MANY OTHER WAYS PATIENTS EXPERIENCE HEALTH AND ILLNESS.”

It takes two!

Different gifts help Cornell in different ways. Annual funds support current needs. Endowment funds provide support now and for the future. Both are important, keeping the university strong year after year and for generation after generation. Here is how they work:

37,793

Annual funds donors

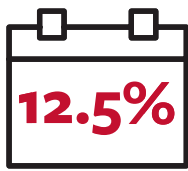

FY17 return on endowment

Annual funds

Twenty-two annual funds across the university, including one for each college, provide immediate financial support when deans and directors need it most. Donors select which fund they would like to support, with their gifts supporting top priorities like student financial aid, new courses and student projects, research, and top faculty hires. The uses of these unrestricted funds vary from year to year depending on new opportunities and rising needs.

Annual funds make an immediate impact and must be spent each year. In FY17 more than 37,000 alumni, parents and friends together helped break the \$40 million mark, touching every student and every program across the university.

Endowment funds

The endowment is the sum of Cornell's permanent invested capital used to generate funds each year for the university. The total endowment is made up of many smaller endowments, with many designated by donors to support specific areas of the university. Virtually all endowed funds are invested. A portion of the earnings are released every year, at a payout rate determined by the board of trustees, to support university priorities and the purposes specified by donors – without withdrawing from the principal.

Rather than serving as a cash reserve, the endowment is the university's financial foundation. Preserving and growing the endowment is the best way to guarantee Cornell's long-term financial health and fulfill its mission.

Cornell provides user-friendly information about its finances. Visit dfa.cornell.edu/financial-guide/.



Annual fund gifts



Endowment gifts



Stronger Cornell

EZRA

CLASS NOTES

NEWS OF FELLOW CORNELLIANS

40 **Clarence Padgham** celebrated his 100th birthday on September 2, 2017 in Sun City Center, FL, as family and many friends gathered to wish him well. Congratulations, Clarence, and thank you for writing! Send news to: ❖ **Class of 1940**, c/o *Cornell Alumni Magazine*, 401 East State St., Suite 301, Ithaca, NY 14850; e-mail, abb83@cornell.edu.

42 Class president **Liz Schlamm** Eddy (NYC) sends the news that she received another thank-you card from the Class of '42 Scholarship recipient, **Elizabeth Stone '18**. Elizabeth hails from Gardiner, MT, and wrote:

"Dear Class of 1942: I am once again writing you out of deep appreciation for your generosity in honoring me with this scholarship. I could not afford to attend Cornell without the funds that you provide. I have probably changed majors since I last wrote you. I have now declared a major in Italian and am planning to study abroad in Bologna in the spring. I'm so excited to spend this time abroad immersed in the language and culture that I love so much!

"Besides Italian, I try to appease as many of my diverse interests as I can here at Cornell, from dabbling in sound design and music production to songwriting and psychology. So many opportunities here! Sometimes I wish I had more time to pursue more of my interests, but there is only so much time in one life, I suppose.

"In closing, I thank you again from the bottom of my heart for making my time at Cornell possible. I've already learned so much here, I can't imagine where I would be now without that opportunity. Thank you."

Liz still receives *Cornell Alumni Magazine* and enjoys reading it very much. In particular, she says she loved the May/June '17 feature story called "A Dog Named Ezra," about alumni who were inspired to name their pets—and sometimes their children—after university founder Ezra Cornell, or other notable Cornell personalities and buildings. "It was the best article I've read in the *Alumni Magazine* since I graduated," she said. The article reminded her of a dog on campus during her senior year—a huge St. Bernard named Buck. "Nobody knew where he came from, but we suspected he lived in a nearby fraternity. They must not have been feeding him enough, so he came to the sorority and we fed him there. One of the girls took him home at the end of the term. I think she lived on a farm, so he had plenty of room." Happy New Year to all, and a peaceful 2018! Send news and memories to: ❖ **Class of 1942**, c/o *Cornell Alumni Magazine*, 401 East State St., Suite 301, Ithaca, NY 14850; e-mail, abb83@cornell.edu.

45 **Phyllis Avery** Olin (Charlottesville, VA) is busy with concerts, piano, paying bills, and enjoying her children, grandchildren, and great-grandchildren. She recently welcomed a new great-grandson—her great-grandchildren now number four boys and two girls. She wishes she could be sailing and traveling, and she would like to hear from **Faye Seelbach** Schmitt. When she was at Cornell, the Psychology department instructors had the greatest impact on her life.

Your scribe, Julie, enjoyed watching the solar eclipse on August 21, though it wasn't total as it was seen from home in Maryland. Her two sons, including **Mark Snell '76**, PhD '80, traveled to Wyoming and were dazzled by totality (and the traffic jam that followed!). Let us hear your news. ❖ **Julie Kamerer** Snell, 3154 Gracefield Rd., Apt. 111, Silver Spring, MD 20904-0806; e-mail, julie.k.snell@gmail.com.

46 Now I will say Happy New Year to all, and continue to have some hope that I will hear from you this new year. I realize that it has become more difficult to move, but not impossible to phone, write, or e-mail a line or two. Enough of my little lecture!

It occurred to me as I am sending this column to *Cornell Alumni Magazine* that this week will celebrate Zinck's night (Thursday, October 19) around the world. It is a great idea. I do remember those scarred tables in the old Ithaca Hotel and singing all those songs. It was always a special, special time. I believe that this is what these columns are about . . . recollections of "good old days" and updating of personal lives.

Priscilla Alden Clement feels like a survivor. Hurricane Irma came right over Naples and made herself heard in her apartment. It took many days before they had safe water for drinking. She is so thankful to be safe. This has been a terrible fall season for so much of the US, and it still continues. Our California fires have not been contained and we are praying for the rains to come. Please send some news! ❖ **Dorothy Taylor** Prey, 1 Baldwin Ave., #501, San Mateo, CA 94401; tel., (650) 342-1196; e-mail, dmprey@aol.com.

Bob "Joe" Nist reported that the Cornell Club of Tampa Bay held a "Back to School" day for students returning to or entering Cornell. A returning student's parents hosted the event, which was memorable for the diversity of its participants and distance from the Hill. Bob was the eldest alum attending. The youngest were several Class of 2021 members. Many were headed for Cornell's Engineering college. "The moderator, **Richard Ahlfield '68**, MBA '70, introduced the guests. Two stories stood out. One Cornell alumnus, raising his family in China, sent his oldest son back to matriculate at Cornell. Present also was a New Jersey minority student rejected by Princeton but accepted by Cornell. He welcomed the counseling that came his way and was anxious to begin his studies in Ithaca. Moderator Ahlfield promised the new Cornellians that with their application in their fields, they would thank Cornell for memories that will never quit."

In the absence of enough news from classmates, I promised to fill in with Lois's and/or my adventures. The setting will usually be Stoneridge Creek (SRC), our continuing care facility/domicile in Pleasanton, CA.

In late 2015, I started growing a full beard. Then, at year's end, scaled down to a mustache. In early 2016, I had business at SRC's reception desk, where Christine Smith was filling in. She noted, "I see you're growing a mustache." I replied, "Do you like it?" "Yes," she said, "It's very becoming." I asked, "Would you like to try it

out?" With her affirmative reply, I ventured behind the counter and delivered a big hug. Sara Siddiqi, who was working nearby, asked, "Am I chopped liver?" I replied, "No way!" and hastened to deliver another of my patented hugs. When I announced that these were free samples, available only today, several female residents requested and received the same treatment.

I hurried home and told Lois of my new business. She reacted, "Are you crazy?" I asked, "What's the problem?" She sagely advised, "It's the height of the flu season. You'll activate your asthma and be sick for weeks." I knew she was right and promised to delay the grand opening until springtime. Meanwhile, I solemnly wrote a parody of my problem to a WWII tune; it will appear in a future column.

Happy New Year, plus our annual reminder: If you have scrapbooks, diaries, letters, photographs, or mementos from the 1940s at Cornell, send them to Evan Earle, Director and University Archivist, Carl A. Kroch Library, Ithaca, NY 14853-5302; tel., (607) 255-3530; fax, (607) 255-9524; e-mail: efe4@cornell.edu. Your survivors will probably toss out such materials, but the university might very well display them. It's better and more ecological to direct them to the university now. Evan advises they have lots of material from the really early days, but very little from the 1940s.

To list your e-mail address in your submissions, e-mail me at the below e-mail address; please include your name, city, and state. ❖ **Paul Levine**, 3273 Streamside Cir., #S-202, Pleasanton, CA 94588; tel., (925) 201-7575; e-mail, pblevine@juno.com. Class website, class of46.alumni.cornell.edu.

47 **Joan Dall** Patton sent this happy news: "I got married on September 16 to a man who lives in the same 'active senior' apartment complex where I have lived since I moved from Sonoma in 2009. My address is still the same. My husband's name is Martin Blair, but I will keep my name. I still play golf, but am finding that my score advances along with my age!"

Shirley Buck Rabeler reports, "My great-granddaughter **Julia Fouts '20** has just transferred from SUNY ESF in Syracuse to Cornell's Ag college as a sophomore. Her family farms in the Cortland-Groton area. Her parents, **Paul '95** and **Laura Kermati Fouts '95**, both graduated from CALS, and I graduated from Human Ecology in 1947. My husband, **Raymond** (deceased), is also a '47 grad (Ag). My father, **Clifford Buck**, graduated in **1922** (Ag). Julia is one of many members of my family who took classes at or graduated from Cornell. The most recent one is granddaughter **Julie Settle** Adamchick '09, DVM '14, who recently worked at an 8,000-cow farm in Minnesota. She is now working on her PhD. Her parents are Cornell grads too, **Mike '79** (Ag) and **Lorinda Rabeler Settle '81** (Engineering). That makes her a fourth-generation Cornellian. Three of my six children graduated from Cornell, plus some spouses." Happy New Year! Please send your news to: ❖ **Class of 1947**, c/o *Cornell Alumni Magazine*, 401 East State St., Suite 301, Ithaca, NY 14850; e-mail, abb83@cornell.edu.

48 We begin this column with a message from our class president, **Martha Clark Mapes**, MS '49. "I am responding to **Ray Tuttle's** suggestion (that we write about how Cornell changed our lives) with my memories and impressions of life at Cornell and Ithaca. Please consider sharing the impact of Cornell on your life and send it to Ray at raytutt@aol.com for inclusion in a future issue and for posting at our upcoming Reunion in June.

"September 24, 2017 is a sunny day here at Kendal at Ithaca on Triphammer Road in Cayuga Heights. I am 91 years old and thinking of my arrival in Ithaca as a freshman at age 18 on November 6, 1944 on the Lehigh Valley Black Diamond from Buffalo, first boarding in Cleveland, OH, on the New York Central. Late at night the taxi delivered me to Balch Hall, on the other end of Triphammer, and my college life and career commenced. In the '40s, the old Ithaca Hotel and the white-spired City Hall were the center of downtown. Ithaca College was tucked in close and Willard Straight Student Union was the social center of Cornell. Uniforms were everywhere: V12, midshipmen, ensigns, and more. In two years the scene changed. Returning GIs joined our class and we have celebrated reunions together as Ithaca has both revitalized downtown and expanded Collegetown. Yet the dogwood and magnolia and beautiful homes are still here, and we love our Ithaca surroundings and Cayuga Lake. 'Ithaka,' the poem by C.P. Cavafy, catches the mood of life that starts here in Ithaca for each of us in different ways. Consider the following excerpted lines:

*As you set out for Ithaka
hope the voyage is a long one,
full of adventure, full of discovery.*

*Hope the voyage is a long one.
May there be many a summer morning when,
with what pleasure, what joy,
you come into the harbors seen for the first time . . .*

*Keep Ithaka always in your mind.
Arriving there is what you are destined for.
But do not hurry the journey at all.
Better it lasts for years,
so you are old by the time you reach the island,
wealthy with all you have gained on the way,
not expecting Ithaka to make you rich.*

*Ithaka gave you the marvelous journey.
Without her you would not have set out.*

"My voyage has been long here. My husband, **Barth '49**, and I had our careers at Cornell in Nutritional Sciences and Animal Sciences. Our daughter and son went to Ithaca schools and our four granddaughters to Lansing. A personal bonus for me was an alumni trip with President Emeritus Frank Rhodes as leader to the original Ithaka in Greece."

Now to news of other classmates, as assembled by your new correspondent, Ray Tuttle. **Jacqueline DeJur** Feinberg stays active with worldwide travel, but still looks back with longing to the '40s in Ithaca. In particular, her time with the *Cornell Daily Sun* and its staff had the greatest impact on her while at Cornell and she would love to hear from any *Sun* colleagues who read this. **Phyllis Flyer** Kavett spends a lot of time on the Internet, reading news and messages, shopping for food and drugs, playing Scrabble, and having fun keeping track of careers of six grandchildren, now ages 25 to

29. While at Cornell, she was most impressed by the library of the Mathematics department in White Hall, with its collection of mathematics objects, and Prof. Walter Carver, teacher of non-Euclidean geometry. Phyllis is researching the work of famous female mathematicians and says she learned much on this from reading the history of France in WWII.

Harold Raynolds, MA '53, remembers his joy and delight in restarting the *Cornell Daily Sun* after WWII. He now recommends *Welcome to the Universe* for its superb educational value and *By Gaslight* as great fiction. His write-up also confirms he was a great fan of **Bob Persons** (more about that in a future issue). **Murray Heimberg**, MNS '49, is now 92 and continues his participation as an endocrinologist, seeing a few patients at the lipid clinic and attending medical rounds as an emeritus professor. He does not expect to attend the 70th Reunion.

Jane Handforth Kester lives in senior living apartments and enjoys the contact it provides. She can happily supplement that with a family that now has 22 grandchildren. Recent books she enjoyed are *All the Light You Cannot See* and *A Shepherd's Life*, particularly the portraits of children growing up during WWII. **Dianne Shapiro** Gasworth retired to Palm Beach, FL, from her position as a New York judge, but still hears a lot about the profession because her children are all attorneys. She is happy to have three grandchildren. In the non-family area, listening to politics and the election antics of last fall, she says, "kept my ears busy and not very happy."

Says Martha Clark Mapes: "Come back to Ithaca this June, and share your stories!" ♦ **Ray Tuttle**, 65 Oyster Reef Dr., Hilton Head Island, SC 29926; e-mail, RayTutt@aol.com.

49 Our class is grieving the loss our Reunion chairman, **Carl Schwarzer**, who passed away March 26, 2017, at his home in Fayetteville, NY. An enthusiastic sailor, Carl was also a US luge official, overseeing the luge start gate for the 1988 and 2002 Olympics. He was married for 51 years to the late Helen Richardson Coleman and is survived by daughters Lynn Schwarzer Knecht of Hubbardsville, NY, and Gail Schwarzer Stack of South Portland, ME. Class president **Jack Gilbert** (Ithaca, NY; ingerjack@msn.com) attended a memorial gathering in Carl's honor and reports that donations may be given in Carl's memory to Cornell Botanic Gardens, 124 Comstock Knoll Drive, Ithaca, NY 14850.

Another star in our class's literary firmament! **Vin Rogers** (Storrs, CT; vinrogers@charter.net) tells us that Amazon has just published *Horse Racing From the Inside Out*, which, he says, "deals with my experiences as rider, racehorse owner, and handicapper." Vin not only enjoys writing, but also "reading, jazz (playing trumpet, flugelhorn), horse racing, politics, and politics!" He adds, "My children are all doing well. Son Evan is a composer, producer, and discoverer of Rihanna! One grandson teaches math at Yale—obviously the talent came from my wife, **Chris (Jennings) '48**." Vin says that if he had a day to spend in Ithaca, he would "stand in the middle of the Quad and absorb its beauty." He notes that the first person he met at Cornell was **Don Asher '47**, MS '48.

Cynthia Foster Clements (Gainesville, FL; cjclements@gator.net) writes, "I guess I'm still 89 years old, since Hurricane Irma spoiled my big 90th birthday plans. Planes were not flying in our area. I'm living in a wonderful retirement center (Oak Hammock at the U. of Florida), where we have all of the faculty perks plus college students

on the staff of our dining room and fitness center. We also have numerous classes right on our campus. Fortunately, my husband, Jack, and I are still enjoying 'independent living.'"

"Will we ever be Chappy again?" asks the headline in the *Ithaca Times* (June 21, 2017) querying whether construction of a new building in Collegetown—replacing the structure that once housed the popular bar the Chapter House—would finally get under way. The bar's home was destroyed by fire in April 2015. Ground was broken for the new building at 400-404 Stewart Avenue two years later, but there have been delays.

Our Reunion is scheduled for June 2019. At present, our headquarters will be at the Statler Hotel, where we shall have all the customary hotel amenities, including elevators for those for whom stairs are a challenge! As the cartoon Paw Patrol says, "No job is too big, no job too small." We say, "No news is too big, no news too small" for our '49 column! Please write, e-mail, phone, or come in person to deliver news to: ♦ **Dorothy Mulhoffer** Solow, 50 Grant St., Wellsboro, PA 16901; tel., (570) 948-9107; e-mail, winspeck@yahoo.com.

50 In the world of commerce, scarcity increases value. Ditto for column-writing. The decline in number of our living classmates increases scarcity of class news reports, which increases their value. So, do your part and keep sending us your increasingly valuable news reports.

First time reporter **Joseph Forman** (Poughkeepsie, NY) mentioned four persons that had the greatest impact on him while on the Hill: Government professor **Clint Rossiter '39**, Engineering professor Charles Weir, and **Harold "Ron" Raynolds '48**, MA '53, and **John Marcham '50**, editors of the *Cornell Daily Sun*.

Peter Rowe (Florence, MA) stays actively involved in hiking, swimming, kayaking, Tai-Chi, and serving on the board of directors of his retirement community. For time off from these, he has taken cruises to St. Petersburg, Russia, and to the West Indies. **Margaret Saecker** Eldred (Marlton, NJ) formerly of Princeton, NJ, is happy to have moved to a retirement home, where she plays bridge and exercises daily with good friends. She's also happy to still be able to drive. **Bill Brownlee** (Chevy Chase, MD) avoids boredom with a variety of activities: council chair, Section 3 of the City of Chevy Chase; trustee of two private schools; winning competitive rowing races with his son; and enjoying time at his vacation home in the north of England.

Richard Silver, MD '53, hematologist and oncologist, is still on the job at NewYork-Presbyterian/Weill Cornell Medical Center, teaching students, residents, and fellows, consulting here and abroad, and doing hematology research. He reported on a clinical trial he participated in that confirmed the effectiveness of Gleevec, a cancer pill that is extending and saving the lives of patients with chronic myelogenous leukemia. Prior to Gleevec, patients had three choices: bone marrow transplant, toxic chemotherapy, or dying. "This has been the thrill of my life," he reported to NBC news. Richard finds time to play the clarinet and tennis, and to maintain contact with Cornell classmates. He mentions Physics professor **Guy Grantham, PhD 1920**, and band director William Campbell as having had a significant impact on him.

Sonia Pressman Fuentes has published her memoirs, *Eat First—You Don't Know What They'll Give You: The Adventures of an Immigrant Family and Their Feminist Daughter*. **Dick Loynd** is still in the business of venture

capital and investment management and reports, “Been lucky—everything going good.” He wishes for a decent Big Red football team “before it’s too late,” presumably referring to his advancing age. He says that it has been his many great Cornell friends that have had the greatest impact on him. **Charles Cole**, PhD ’57 (State College, PA) only reported that he would like to hear from **Jim Tregurtha** and **Alfred Ginty ’51**. Listen up, you two.

We got a note from **John Griswold** (Woodsville, NH) last spring, who reported that he had contracted pancreatic cancer. Unfortunately, John died on October 17, 2017. When he wrote, he was still playing the tenor sax, clarinet, and flute in a small combo for the entertainment of community groups. (He said his sax is the same one he played in the Big Red Band back on campus.) John cited John Munschauer in career planning as the person most responsible for getting him into a productive and successful career as a business research and management consultant. He referred to Munschauer’s book, *Jobs for English Majors and Other Smart People*.

From your co-correspondent: Life is sometimes difficult for a true Cornellian out here in Iowa, where Cornell refers to Cornell College, a small but fine liberal arts college in Mt. Vernon, IA, and Big Red refers to the U. of Nebraska, quite specifically to its football team. In conversation, once we get that difference straightened out, there is the problem of attempting to explain why, unlike Midwestern states, New York State does not have a U. of New York and a companion New York State U. of Agriculture and Mechanics with Division One football and basketball teams—state universities such as Iowa and Iowa State, Kansas and Kansas State, Oklahoma and Oklahoma State, and so on. Of course, this involves the engaging story of how Ezra Cornell, with his friend Andrew Dickson White, persuaded the New York legislature to place the Morrill Act’s statutory or contract colleges of Agriculture and Life Sciences, Human Ecology, Industrial and Labor Relations, and Veterinary Medicine on his private Ivy League campus. That meant that when I was on campus, enrolled in the College of Agriculture, my roommate and I attended the same science, English, and history classes while he paid tuition and I paid none.

I lived in New York State for my first 40 years and had no such state teams to root for. Now I have Iowa and Iowa State to cheer for, assisted by three grandkids as graduates of the former and two from the latter. Our sports team loyalties are also shared with kids or grandkids as graduates of Colorado, Wisconsin, Drake, Rockford, Columbia (Chicago), Wartburg, and Princeton. A happy legacy for an aging Cornellian.

Have you noticed that as you have aged, memories of your early life pop up and are remembered quite clearly? We could use some of your stories, especially ones from your time on the Hill. You’d be surprised how welcome such stories would be to our classmates and other readers of this column. ♦ **Paul Joslin**, 13731 Hickman Rd. #4207, Urbandale, IA 50323; tel., (515) 278-0960; e-mail, phjoslin@aol.com; **Patricia Carry Stewart**, 2613 N. Ocean Blvd., Gulf Stream, FL 33483; tel., (561) 278-5387; e-mail, stewartpc@aol.com.

51 Happy New Year to all! Please take a moment to send us an update. Whether your news is usual or unusual, conventional or surprising, we want to share it with your classmates. Send your holiday letters and updates to: ♦ **Brad Bond**, 101 Hillside Way, Marietta, OH 45750; tel., (740) 374-6715; e-mail, bbond101@suddenlink.net.

52 You will get this after Christmas, but today it is mid-October. You would never know it from the temperature. We just drove from Black Mountain, NC, and spent time on the Blue Ridge Parkway. It was lovely, but back in Pittsburgh there is not the color you might expect on Columbus Day.

Now to the mailbag, all of which dates back to last spring. **Clifford Eddy** (Rochester, NY; cedly001@rochester.rr.com) e-mailed that after his PhD in chemistry from the U. of Rochester, he spent many happy

relatively well in New Canaan. Still singing in choir and volunteering at Staying Put in New Canaan, the New Canaan community center and church.” She was “EAGERLY” awaiting the April arrival of her first great-grandchild—a girl. At the time, Judy had a bad cold and was tired of winter. She planned to take the Cornell trip to Apulia, Italy, in the fall and orchestrate a summer family reunion in Vermont. Other thoughts: “I would love to see many classmates at Reunion and many Cornellians (my era) on the trip to Apulia.” **Joan Schmeckpeper Richards**

‘Lewis Ward-Baker has been singing on the stage of the Eastman Theatre with wonderful orchestras.’

JOAN BOFFA GAUL ’52

years working for “the burgeoning Xerox Corp. After retiring from Xerox, I found, in time, a new scientific interest: global warming, or climate change as it is now known.” He reports that by application of his education and experience with several years of research on the subject, he believes that the threat of damage to the environment is overblown. **Irwin** and **Arline Braverman Broida** are in Wayne, NJ (ibroida@yahoo.com). Arline wrote, “Irwin and I have attended every Reunion since graduation, but, unfortunately, Irwin’s poor health prevents us from enjoying the 65th. Regards to all our ’52 classmates and “Thank you, Cornell!”” **Joan Cruthers Flood** (Raleigh, NC; flood.j3@aol.com) wrote, “I’m slowing down, still in my large house, and attempting to keep up with all my gardening—time flies, though, or maybe it’s me!” Regarding plans, she says, “Who knows?”

Howard, PhD ’54, and **Aliza Goldberger Shevrin** live in Ann Arbor, MI (shevrin@umich.edu). Aliza writes, “I’m trying to age gracefully, acting as my husband’s caregiver during his several illnesses.” She has been keeping up with her large family, including a 1-1/2-year-old great-granddaughter. She has several Yiddish reading and conversation groups and does her exercises to remain in good health. She tries to do some travel and has recently done a cruise and been to London and New York. **John Crager** (Hudson, NY) wrote that he planned to celebrate his 90th last summer “at the Spirit of Hudson with a cake in the shape of my Navy ship.” **Catharine Jones Gaskill**, BS Nurs ’52 (Orange City, FL) wrote that she was “enjoying retirement.” She was also publishing her fourth book, *Schoolmarm*.

Walter Harrison (Stanford, CA; walt@stanford.edu) writes, “Still living with **Lucy (Carley), MD ’53**, in our house on the Stanford campus. Retired from teaching, but still consulting.” **Gretchen Lawson Bost** is in Newton, NC. Her e-mail address is glbost@charter.net. **Frederick Rubinstein**, LLB ’55 (New York, NY; frubinstein@kelleydrye.com) is “still practicing law part time at Kelley Drye and watching my 9-year-old granddaughter’s progress at the John McEnroe Tennis Training Camp.” He has been active with Common Cause—“the non-partisan organization pushing to get money out of politics (how timely!) and get rid of gerrymandering.” He also planned to take a Viking Cruise on the Danube in June.

Judith Calhoun Schurman (New Canaan, CT; schurma1@optonline.net) wrote that she was “alive and

Torelli (Boynton Beach, FL) was looking forward to attending Reunion last June. In 2016 she had visited two Cornell friends, **Denise Cutler Kimball** in San Diego, and **Joanne Holloway McPherson** in Ohio.

Lewis Ward-Baker (Rochester, NY) e-mailed his news. He had been making a daily effort to “keep our home warm, reasonably organized, and full of love. There will soon be four great-grandchildren. Who knew that my little babies would someday be grandparents? It just doesn’t compute!” Lewis has been singing in a quartet, choirs, and large choruses on the stage of the Eastman Theatre with wonderful orchestras. The first person he met at Cornell? “I think my first experience on campus was with the admissions officer. Was his name Williams?” What he would do if he had a day in Ithaca? “Just sit on the grass of the Arts Quad and remember.” [Ed. note: Questions on the university’s online news form are not the same as those on the printed news form.]

James Clarke (Columbia, SC; carosyn@bellsouth.net) wrote, “I am watching newly planted pines grow on our pine plantation in South Carolina—a big leap from a BCE at Cornell. Then **Fred H. “Dusty” Rhodes, PhD 1914**, said, “You can do anything after you finish here.” **Ann Coffeen Turner** (Mendham, NJ; harann52@yahoo.com) wrote, “Still tutoring dyslexics and late bloomers at Gill St. Bernard’s school, where I’ve been for 39 years. I’m down to four days a week, and I’m giving away my teaching materials on the net (www.mnemonicpictures.com). Wishing I could tell **Harvey**, who died in 2015, about all the stuff that’s going on in the world.” Ann plans to work as long as she can. Other thoughts? “Favorite professor: the wise and kind and wonderfully funny **George Healey, PhD ’47**.”

Irwin Sitkin (Aventura, FL; isitkin0402@gmail.com) wrote that he and Helen had looked at several ways of getting to Reunion in June, without success. They winter in Aventura and summer on Cape Cod. It was difficult to travel from Chatham to Ithaca, and too many of their old gang and spouses were unable to attend. “So for the first time since 1982, we’ll be among the missing.” Irwin continued, “Our health continues better than good (i.e., normal aches and pains). Our children, Jill, Marc, and Judi, are also retired. I continue playing golf at least twice a week—with my fifth hole-in-one last November. We also enjoy visiting with friends and relatives, especially on our leisurely drive between Florida and Cape

Cod. **Paul Schlein**, MD '56 (Bethesda, MD; palsal301@netscape.net) is a retired internist. He wrote, "Sally and I moved into a retirement place, but not to worry—still playing tennis twice a week, often with **George Cohen '55**, LLB '58. Also play duplicate bridge with **Marty Convisser '53**." Paul planned to "spend a glorious week on campus this summer studying *From Democracy to Authoritarianism: The Death of the Roman Republic* with Cornell's Adult University. (Any connection to today's newspaper is purely coincidental!)"

million specimens of flora, fauna, meteorites, and cultural artifacts and had access to research collections not on display when they were there. **Louise "Polly" Hospital Flansburgh '54**, wife of our late classmate **Earl**, attended Broadway plays that Altschuler selected for a CAU New York theater weekend: the 2017 Tony winner *Oslo* at Lincoln Center, the true story of unlikely friendships and great heroics that led to the 1993 Oslo Peace Accords between Israel and the Palestine Liberation Organization; the Drama Desk Award-winning

by home at times as she makes and donates baskets of chocolates to the Alzheimer's wing of a local home.

Ann Heagle has been a loyal volunteer at the Dallas/Fort Worth Int'l Airport for years. How many times do you suppose she has patiently answered the same questions over the years? Dealing with the public can be a challenge. She is hoping to take a break in the near future and explore more of our national parks. It was a joy to hear from **Robert Hellman**, MS '57, once more. Robert developed his lifelong interest in conservation from professors Allen and Kellogg while an undergraduate. He is a keen observer of the outdoors and now has six and a half acres that he's transformed from scrub and field into forest by using native species. He is still active in husbanding his land and leads groups interested in land management through his "classroom." He belongs to a couple of writers' groups and hopes to publish soon. **Virginia Beamer** Weinhold has resided at her present location in Worthington, OH, since moving there in 1972. She is involved in various condominium functions and, when the weather is right, helping out with pool duties. Having accomplished many travel and career goals she is happy with what she has done.

Jan Jakes Kunz, our web designer, suggests, should you like to watch the video of the dedication of Cornell Tech or the inauguration of our new president, Martha Pollack, both are available on our website, the address of which is always at the end of the column. If planning a trip, you might check out **Jim** and **Joan Symon's** extensive photo album on the site, which shows their many adventures around the globe. Their photos can be found on our community page, where they are alphabetized. Settle in, relax, and enjoy their travels and delightful photographs. Should you wish to contact Jim with comments or questions, his e-mail is listed on the page. Happy trails, everyone.

I have been meaning to ask for years if any of you have an extra yearbook or know of one that is available. If you do, would you please e-mail me? After 20 years of constant use, mine is in shreds. Thank you. ❖ **Les Papenfus** Reed, lesiejreed@me.com. Class website, classof54.alumni.cornell.edu.

55 **Martin London** sends congratulations to his former roommate, **Marcus Reidenberg**, whose news we brought you in the Sept/Oct issue. Marcus is now professor emeritus of pharmacology at Weill Cornell and serves on several other health-related panels and committees. Marty said, "Glad to see recognition of his accomplishments." Marty goes on, "I write from Montauk, NY, where my principal occupation these days has been fishing for striped bass (whose principal occupation these days seems to be to frustrate my principal occupation). Sigh. I guess that's why they call it 'fishing,' not 'catching.' Much time being taken up by dealing with the mechanics of my recently published memoir, *The Client Decides*, in which I write about my representation of clients like Jackie Onassis and vice presidents Spiro Agnew and Hubert Humphrey, and my successful litigated opposition to the likes of Donald Trump and Roy Cohn. Available on Amazon, the preliminary reviews are excellent. Other than that, and winters in St. Barths, life is good. I'm in regular touch with several classmates, especially the old Sammy crowd. Can't help but wonder if the Big Red's football mania has been affected by the concussion scare. And I think back to my election not to go into advanced ROTC, which led eventually to my meeting Mario Puzo, who helped resolve a snafu in my subsequent military service. Ahh, the minor decisions we made on the Hill!"

'Emita Brady Hill is working on an oral history of ballroom dancers.'

JOHN SEILER '57

Recently, **Dori Crozier** Warren sent me two obituaries. One was for **Christine Auzia** Bain, who died September 4, 2017. Christine, a librarian active in the Albany area, was a bookbinder and president of the Capital Area Bibliophiles. The second was for **Mary Shear Brennan**, who died in Schenectady on August 16, 2017. Mary helped her husband, **Jack, DVM '52**, establish his veterinary practice. She handled the operational side while he handled the animals. She was an active civic, 4-H, and school volunteer, and co-authored *A Guide to the Natural Areas of Albany County*. Each woman led a worthwhile life, raised loving families, and had many friends who will miss them. ❖ **Joan Boffa** Gaul, joan.gaul@mac.com. Class website, Classof52.alumni.cornell.edu.

53 June will be busting out all over—not busting out like a ChemE who can't handle advanced math, but more like the young Virginia creepers that have been hugging the bejeepers outta all the mornin' glories on the fence (as Columbiac Oscar Hammerstein phrased it) before we know it. So we gently remind all '53ers that our 65th Reunion—June 7-10 at the Statler—is edging ever nearer and will arrive sooner than lots of people may think. The Statler will be '53 headquarters, but some may opt to bunk elsewhere. Of course, it won't be too late to sign up until noon Sunday, June 10. Co-planners **Dick Halberstadt** and **Caroline Mulford** Owens have been building better banquets and parties, etc., including dinner with feathered friends at the Lab of Ornithology at Sapsucker Woods and mellow music from Jack Brophy's Cayuga's Waiters of the Fifties at a Saturday class lunch. (These Waiters have not been banned.) We can't promise anything about the weather, but you'll want to hear President Martha Pollack's State of the University address. You've probably seen more details, undetermined at this writing, but guaranteed to be Cornell quality.

Cornell's Adult University lures people fairly far from Finger Lakes of blue. The much-admired **Glenn Altschuler, PhD '76**, dean of Cornell's School of Continuing Education and the Thomas and Dorothy Litwin Professor of American Studies at Cornell, attracted **Ira** and **Myrna Zimmerman Miller '54** to an inside view of the Smithsonian's National Museum of American History, from the original "Star Spangled Banner" to Archie Bunker's chair. The students checked out some of the Smithsonian's National Museum of Natural History's 126

musical *Come From Away*, the true story of a small town that welcomed the world; and Arthur Miller's 1968 drama, *The Price*, of a struggle to make peace with the past and create hope for the future. Smithsonian attendees were cautioned that the event is "moderately strenuous . . . the ability to walk for more than a mile (is assumed) . . . and to stand for some period of time . . . comfortable shoes are a must."

Bill Gratz reports '53 sightings at the August inauguration of President Pollack. He saw the **Bill Bellamys**, the **Bob Abramses**, **Mort Lowenthal**, and **Roz Zalutsky** Baron. Roz was accompanied by her fiancé, a friend of her late husband, Phil. Cornell's 14th president, speaking under a bright sun fanned by a cooling breeze, spoke for 25 minutes to representatives of many colleges proudly adorned in gowns of many colors, plus a throng of Cornellians. "There's a compelling synergy," she said, "between liberal arts on the one hand and professional studies across a swath of disciplines on the other." And she quoted former New York Senator Daniel Moynihan: "You are entitled to your own opinions, but not your own facts." ❖ **Jim Hanchett**, 300 First Ave. #8B, New York, NY 10009; e-mail, jch46@cornell.edu.

54 I think this is a first. I left you at the end of the Nov/Dec issue with a report from **Stephen Krauss** saying he had had a triple bypass in April 2016. I am back to continue Steve's adventures. Using his brain and his feet, he left two months later to hike the San Juan Mountains of Colorado—altitude 10,600 feet—with his children and his grands. Then in September, he and Carol spent a week in Paris before continuing on to the south of France for two weeks of walking tours—first to Menton, on the Côte d'Azur, for a week of warm-ups of five to nine miles each day, and thence to Provence to hike in rougher terrain, where he was still able to keep up with those a bit younger. Steve has set a high bar for the class, but he also serves as inspiration. Thanks, Steve.

Robert Jennings moved to Milton, DE, where he and Kathleen are enjoying retirement in a senior-friendly town. Bob volunteers his time as chaplain at the hospital and an adult daycare center. We can add Bob to the list of Vladimir Nabokov's many admirers. He is the professor remembered the most from across all disciplines. **Jane Gregory** Wilson is still in constant motion on the high seas. Jane gives her home address as Sun City Center, FL, but I doubt she is there much. In this past year, she has crossed the Atlantic twice. However, she must stop

Philip Harvey went to Ithaca last fall to participate in the funerals of two former wrestling teammates. He relates, "On Saturday, October 14, I gave a remembrance to my good friend and teammate **Rexford Boda**. A few of us spoke at his gravesite. A reception followed at the church where Rex had worshiped during his youth. From Rex's service, I went directly to the Roman Catholic Church in Ithaca, where a memorial Mass was held honoring my teammate **Frank Bettucci**, MBA '58. A very nice luncheon was held at the Statler on Cornell's campus, where **Orlando Turco** (Frank's best friend), **David Auble '60**, MBA '62, and I offered remembrances. Frank had been a national champion and the Outstanding Wrestler at the 1953 Division 1 National Championships. He was also a member of our 1956 Olympic team."

Andy Dadagian, the newest member of our class council, is certainly having a busy and active life. Here's his report: "Having just celebrated my 86th birthday by cycling 27 miles and remaining the oldest active surgeon in our three-hospital group, the only thing worth sharing with my classmates and track teammates is the embarrassing fact that, thus far, I have been a miserable failure in influencing my college-bound grandchildren to attend Cornell." However disappointing that may be, I imagine it's compensated by the facts that his oldest graduated from Stanford, his namesake Andy from Harvard, and a granddaughter from Bowdoin. Two others are still in college, and there are "six more grandchildren to go!" Andy sums up, "Life is good, despite my grandchildren attending lesser institutions." Good-natured humblebrag at its best!

John Diggins sent the following update: "Seeing **Sylvia Verin Mangalam**, MA '57's brag [Sept/Oct column] about bike riding pushed me into my own fitness brag. I still ride my bike, sail my sunfish, kayak (with wife **Pat (Drew) '56**) year-round, take no medicine, and donate blood on a regular basis. I started donating in the fall of '51 and chaired the Cornell blood drives for three years and never stopped. Life on Padre Island is wonderful!" Great to hear from you, John. And a final note to all: I hope you're checking our class website regularly. You'll find it a treasure trove of good info—from past '55 memories to upcoming plans and events, such as our 65th Reunion (June 2020) and the great news that our class headquarters will be the Statler! There are also many recent pictures to show you what's going on right now on campus. Just go to: classof55.alumni.cornell.edu. ❖ **Nancy Savage** Petrie, nancysavagepetrie@yahoo.com.

56 Seen in the *New York Times* on the op-ed page: a terrific column by our classmate **Susan Warhaftig Brownmiller** on the subject of women and Hugh Hefner at the time of his passing. If you missed reading it, you can always search on the *Times* website.

Neil Beecher (Los Angeles, CA) retired after 34 years working for Carnation (Nestlé) in product development and then three years with Baskin Robbins. Neil visited Cornell in 2011 and found our upper campus unrecognizable from 1956. For those of us who have come back often, it's hard to remember the 1956 campus. **Harvey Hammer** (Morristown, NJ) proudly mentioned that his grandchildren are students at Cornell. **Julia Lehman '21** started this fall, joining her brother **Matthew Lehman '19**. Their mother, he notes, is **Melinda Hammer Lehman '89**. Says Harvey: "I, of course, have a 'perpetual smile' since receiving the good news about Julia." He is still practicing psychiatry and is medical director of a clinic at his local university.

Patricia Smith Born is now living at the Hill at White-marsh, a retirement community in the suburbs of Philadelphia, where she is a neighbor of classmates **Bill and Jan Charles Lutz** and **Roberta Grunert DeVries**. **Bonnie Smith** Whyte (Reston, VA) continues her work as a docent at the Preston Museum. She is also a coach of the Reston Runners, and a board member for local transportation issues. **Lenore Brotman** Greenstein (Naples, FL) says she's busier now in retirement—with both volunteer and family activities—than she ever was while she was working. Lenny is coordinator of the Women's Cultural Alliance in Naples, serving hundreds of bright, motivated women in retirement. She's still playing tennis, taking Pilates, yoga, and dance classes, and spending summers in Tanglewood in the Berkshires—"my spiritual home," she says.

Arthur Gast has moved to Sterling, VA. "I enjoyed ten years with the Cornell Club of Cape Cod as program chairman until our move to Virginia in 2013," he writes. We heard from **Baxter Webb's** wife, Ann, last spring. Baxter was having health issues, so she connected with us for him. Unfortunately, Baxter passed away over the summer, on June 10, 2017. He was six years older than most of us, having graduated from the U. of Georgia in 1950 and serving in the Korean War before coming to the Cornell Hotel school which, Ann says, he always credited with putting him on the right path for his life's work in the hospitality field.

A few classmates checked in with short news items: **Thomas Witschi** is a retired orthopaedic surgeon living in Wading River, NY. **Orlando Turco** (Ithaca, NY) retired in 2013 and recently followed Cornell's wrestling team to the Eastern Intercollegiate Wrestling Assn. and NCAA tournaments. **Betty Specht** Rossiter (Pasadena, CA) was sorry to have missed our Reunion, but says she enjoyed watching the '56 class program online. **Nancy Van Valkenburg** Seroff (Rego Park, NY) is taking it easy, exercising at the Y a few times a week, shopping and cooking, and watching TV and movies. **Miriam Mattinen** Shearing is still living in Las Vegas, NV. **Vera Johnson** Lee is singing with the San Francisco Choral Society and the choir of the Unitarian Universalist Society of San Francisco. She recently went on a concert tour of Italy, where they sang in Naples, Rome, Pisa, Florence, and Lecco.

Barbara Rapoport is enjoying her annual city, Paris, France. And I am enjoying my weekly bridge game at the New York Cornell Club, where I always see familiar faces. Keep your good news coming. ❖ **Phyllis Bosworth**, Phylboz@aol.com. Online news form, <http://alumni.cornell.edu/class-notes/>.

57 Does anyone know where **Mike Makar** might be? **Lee Cornaire** (lcornaire@empacc.net) wants to know.

Susan Breslow Dillon reports moving from Merrick, Long Island, after 50 years in the same house, to Somers, NY, with daughter Alice. She is also now only a few minutes away from daughter **Eleanor Dillon** Petigrow '87, Eleanor's daughter **Samara '16**, MA '17, and the rest of their family. Susan visited Ithaca three times in 2017. She represented the '50s on a panel at Willard Straight for the 100th celebration of the Alpha chapter of SDT, recalling having written her mother 60 years ago on the 40th anniversary. In May, she attended graduation when Samara received a master's degree, and wound up the travels at Reunion as Eleanor celebrated her 30th.

Your correspondent had to take a nap after trying to digest all the activities in which **Emita Brady** Hill has been involved. She is chancellor emerita of Indiana U.,

Kokomo and founder of the Bronx Inst. at Lehman College (CUNY). Her book *Bronx Faces and Voices* (available via Amazon) came out in 2014, and she is currently working on an oral history of ballroom dancers and a regional oral history on women involved in the food industry in Northern Michigan. She is also an author, editor, dancer, historian, and grandmother, with three children: a nurse practitioner, a professor of biology, and a chef.

Jan Klein Surasky has also authored a book, *The Lilac Bush Is Blooming*, which she has actively promoted since last fall (www.jansurasky.com). **Don, PhD '60**, and **Barbara Ress Rotenberg** have moved into a charming villa in a retirement center in Tulsa, OK, and are enjoying the many activities associated with their new surroundings. Their granddaughter's high school graduation prevented them from attending our 60th Reunion.

Susan Hitz Magnuson enjoys cheering on three grandsons in various sporting events. She plays lots of bridge, reads as much as possible, and is developing a family website. She and Guy have been married 55 years and are glad that their two daughters keep them busy. **Barbara Baltzel Burton** reports that she and **Sandy '58**, MS '63, follow closely the comings and goings of their five grandchildren (four in college and one a high school senior). She hits it on the head in writing her response to Cornell's impact on her: "Just being a Cornellian was special." **Walter Wills** also boasts of adventure-some granddaughters, one the high scorer on her high school soccer team and the other a veteran hiker, having traversed the Appalachian Trail, starting in Maine.

Henry and Grace **Kammerer** have moved from one Buffalo suburb (Grand Island) to another (Williamsville), and Henry has recently ended 15 years of consulting in rocket engine metallurgy for Moog. As an aside, your correspondent spent several years in Williamsville, only once being unable to get downtown in the morning (black ice on the roads forced me to go home after one block of effort and medicate myself with a Bloody Mary). **Chuck LaForge** had another weather challenge, surviving Hurricane Irma on the southeastern coast of Florida. We lost another giant when **Chuck Knight**, MBA '59, passed away last fall. His leadership of Emerson Electric, along with **Bob Staley**, MBA '59, and the also recently deceased **Al Suter**, MBA '59, is legendary.

Harriett and I greatly enjoyed a visit from **Tom Keating** in September. He was returning from helping his brother-in-law move into a retirement community in North Carolina and on his way to Minnesota when he spent a few wonderful days with us in Louisville. After finishing a few columns writing for both the boys and girls, I have concluded that there is no question but that the females of the species are light-years ahead in the handwriting department. ❖ **John Seiler**, suitcase2@aol.com.

58 I am writing this column in mid-October, but you will be reading it in the New Year! Time to start making plans for our 60th Reunion! Hard to believe, but time sure flies.

Dale Reis Johnson is enjoying retirement, playing lots of duplicate bridge and traveling often. She and husband **Dick '57** attended his 60th Reunion last June and spent time with **Bill '57** and **Jan Charles Lutz '57**. **Judith Schlein** Marlane is a professor emerita of cinema and TV arts after 22 years at California State U., Northridge. She is currently writing her fourth book and had a big party for her 80th birthday. She says, "I can't believe that number, but am thrilled to be so busy and active!" She has three daughters, all Cornell graduates, and a 14-year-old grandson who is an incredible pilot.

Sonja Kischner Wilkin is looking forward to our 60th and would like to encourage all her sorority sisters to join her! At our 2013 Reunion, she attended the Women's Forum. She has stayed very active on the national Village Movement and is very busy getting ready for "Launch Party Day" for the Clayton Valley Village, which will provide volunteer services to seniors wanting to stay in their own homes as long as possible and allow members to enjoy social, educational, and healthy activities.

On a sad note, we received news of the death of **Rudi Metzner**, MS '64, in September. He had been diagnosed with cancer in April, but was in such good shape that he was able to hold on without much difficulty until the last week of his life. Rudi will be sorely missed by those many classmates who knew him.

Phil Gellert, MS '60, writes of his family's wonderful association with Cornell. His grandson just graduated from Cornell and another one just started this year. They are the fourth generation of his family to be there. He states, "As for me, I am still involved in various real estate activities with no plans of retiring. I take a vacation almost once a month, often traveling to different destinations around the world, one-on-one either with one of our five kids or my wife, Joan. My other pursuits include skiing in the States or abroad (averaging 30 days on the slopes), hunting, and hobby farming."

David Hill retired from the EPA and is raising beef cattle and playing the French horn and cello. **Harry Coren** is partially retired, working only Monday through Thursday from 11:30 to 4:30. He is involved with psychoanalysis and psychiatry of adults, children, and adolescents. **Liz Fuchs** Fillo keeps busy with music, gardening, and politics. She did a one-woman cabaret show for her 80th to benefit the Young Audiences

organization. She is putting together another show to benefit the Princeton library and children's chorus. She is part of the Cayuga's Waiters of the '50s, who sing at Reunions.

Ronni Schulbaum Strell keeps busy with volunteering and friends. She is on the board of Women at Leisure and helps with all their activities. She plays mahjong with a group of friends every Saturday afternoon at the food court of a local shopping center, travels for fun, and keeps in touch with **Dottie Berens** Greenspan and **Arlene Scharf** Kelvin, her roommates. They meet in NYC when they can. **Anna Schuler** Cushwa writes that she has one husband, five children, and nine grandchildren who keep her busy with weddings, graduations, and activities! She is also looking forward to our Reunion. **Martin Steinberg** is still working, although he has decided to winter over in Naples, FL, to avoid the snow in Boston. He can work remotely, and loves it! He is a professor of medicine at Boston U. and just received a new four-year NIH grant. "As is sometimes said in research," he notes, "the idea is to die funded!"

Reunion plans are in full swing as the committee gathers at CALC in early February to firm them up. Our venue at Mews Hall on North Campus is excellent, and all classmates should have received, by postcard last October, the early signup info for the Statler or other local hotels and motels. The registration package will be mailed in late March for signing up for all events. **Dick**, PhD '65, and **Connie Case Haggard** are working on contacting at least three others to join them June 7-10, 2018. Maybe you, too, can call three or more classmates who you would most like to have with you at Reunion and get them to come. Check our class blog for updates and continuing information at: <https://58at55th.wordpress.com/>. Happy New Year to all! ❖ **Jan Arps** Jarvie, janjarvie@gmail.com; **Dick Haggard**, richardhaggard11@gmail.com.

Many Cornellians gathered at Hunter College in NYC on September 12 to celebrate and commemorate the life of **Bill Woods**, BArch '60, the NYC urban planner who died in May. Among those present at the memorial were **Bob Furno**, BArch '61, **Jay Labarthe**, BArch '60, **Marty Lehman**, BArch '60, and **Frank Mead**, BArch '60, all architects from '60 and '61. Also present were **Robert Dann**, **Charles Carpenter**, MD '63, **Neil Janovic**, **Nelson Joyner**, **Carroll Olton** Labarthe, and **Harry Petchesky**. "Bill's master plan for the development of the New York waterfront is a true legacy," says Marty, a conviction shared by many in New York and in the architectural community.

Dan Braunstein, who retired to Davis, CA, in 2002, is chair of Healthcare for All-California, a statewide non-partisan organization of volunteers working to achieve universal healthcare through a publicly financed single-payer system. Dan also volunteers for the Mondavi Center for the Performing Arts, a venue located on the UC Davis campus. And he still finds time for yearly international travel. Until recently, **Nancy Iams** Walsh also lived in California, but at the beginning of May she retired from her part-time job, packed up her apartment, and moved to San Antonio, TX. "Although I loved living in California, like many in our class I turned 80 this year and decided I should be living closer to family. I am enjoying doing things with my daughter Kathy and her family. Neighbors in my apartment complex and people at my new church have been very welcoming, so I am settling in quite well," she writes.

Jim Glenn has installed a 3.9 KW photovoltaic array on the ground just north of his Taos, NM, home. The south-facing, 250-sq.-ft. array capitalizes on the 300 days of sunshine that Taos receives annually. Jim expects that the system will meet most of his household needs during sunny days, and he will sell any excess power to his current electricity supplier, the Kit Carson Electric Cooperative. He plans to install a battery that will store the excess electricity produced during the day, meeting his power needs 24 hours a day and making him independent of the grid both day and night.

"When my life is interrupted by unsolicited telemarketing callers taking invasive surveys, selling 'free' cruises or timeshares in Florida, threatening action on bogus debts, or raising money for police collection scams, I have some fun," reports **Bob Mayers**, BArch '61. "I pose absurd, impossible problems that must be solved to close the deal. This work, which reduces telemarketing calls to other American homes, represents my volunteer service to the community." Bob is now sharing recordings of these calls on his website, sellphonies.com, and they are hilarious. At least one, "Pet Problems," had its genesis at Cornell during our junior year, when Bob and his roommate, **Burt Sabol**, needed to find a new apartment. "After many boring calls to landlords inquiring about places to rent, I decided to turn the chore into an experiment: what would it take to make a landlord absolutely refuse to rent to us? I posed as a biology graduate student looking for a place I could live and do my experiments. Each time I got a negative response I upped my offer by \$100 and added a new horror to the deal. It was truly amazing how far some would go." ❖ **Jenny Tesar**, jet24@cornell.edu.

60 Hello, classmates. First off, let me report that some e-mails from your class officers and Alumni Affairs to your "In" boxes have been bouncing back in recent months, so if you haven't heard from any of us lately, we suggest you verify that your e-mail address

Save the Date for our 60th Reunion



June 7-10, 2018

Full program info and registration materials are sent in late March.

Contact:

Dick and Connie Haggard
richardhaggard11@gmail.com
choirconnie@gmail.com

59 At a ceremony at the Statler Hotel on October 21, **Ron Demer** was among six alumni to receive the Frank H.T. Rhodes Exemplary Alumni Service Award. This prestigious award recognizes alumni who have demonstrated extraordinary service to Cornell through long-term volunteer activity. Classmates attending the event included **Ellie Applewhaite**, **Alan Rosenthal** (both of them previous recipients of the award), **Kent Hewitt**, and **Bill Kingston**.

The program noted that "Ron's extensive and enthusiastic volunteer engagement grows out of the love he's had for the university since he was a student. 'I just had a wonderful experience at Cornell,' he says. 'I loved it from the first day I saw it.' The love and involvement continued soon after he graduated when asked to serve as the Class of '59 Cornell Fund rep. He took it on, winning an award for greatest participation improvement. He hasn't stopped volunteering since. Ron is serving his second tour as the president of the Class of 1959. When he [first] became class president he spent two weekends adding a handwritten note to those classmates he knew or was acquainted with in a class membership mailing, precipitating a jump in duespayers. He is '59 Reunion chair for 2019 and was co-chair of his 50th Reunion in 2009. In addition to leadership of his class, Ron served as president of the Cornell Club of Boston and as president of the Cornell Alumni Assn. of Atlanta. He was a Cornell Alumni Admissions Ambassador Network (CAAAN) volunteer in both cities. Ron served multiple terms on the Cornell University Council and on the Fraternity and Sorority Advisory Council."

and other personal information are up to date in the alumni directory. Do this yourself online by reviewing your profile at <https://cornellconnect.cornell.edu>, or by contacting **Kate Freyer** in Alumni Affairs at kate.freyer@cornell.edu. Also, be sure to send news for this column directly to me, **Judy Bryant Wittenberg**, at jw275@cornell.edu. My trove is diminishing rapidly and needs replenishment!

Class president **Sue Phelps Day**, MEd '62, passed along a letter from curator Katherine Reagan at the University Library thanking us for our Class of 1960 Rare Books and Manuscripts endowment, which supports acquisitions of rare material, particularly in the humanities. "Thanks to this fund," she writes, "I was able to purchase several items over the past year, including works for the Witchcraft Collection, established by Andrew Dickson White in the 1870s, one of the most important collections in the world on European witchcraft." Maybe some of you were on campus in the fall and saw the witchcraft exhibition that opened, appropriately, on Halloween.

Good to hear that some classmates are taking advantage of Cornell's Adult University offerings, both on campus and elsewhere. **David Atkinson** went to Ithaca for a course on Global Food Systems and joined a study tour on Spring Migration in Cape May; **Evalyn Edwards Milman** was in NYC for a Spring Theater Weekend; and back on campus, **Arthur Field** studied Sharia: The Origins and Workings of Islam, while **Lynne Keefe Verna** had a class on What Your Genes Can Tell You. CAU opportunities for 2018, including study tours and on-campus classes, were announced in the fall; check them out online at cau.cornell.edu.

Barbara Anderson Everett (South Yarmouth, MA) reports that she and John "moved to Cape Cod in July 2016 and have had a fabulous time since, with lots of visitors and getting re-acquainted with the Cape and the rest of New England. Being a native of the region, I am ecstatic to be 'home.' Happily, John is thoroughly enjoying it also. Last spring, we had a marvelous visit with **Jessie Barker Hill** at her home on the Island of Nevis, a historic and beautifully tropical place. Jessie was a splendid host and guide." The Everetts have also spent time visiting their five children and 13 grandchildren in California, Florida, Maryland, North Carolina, and New York, and longtime friends in many places. Barbara adds, "I'm becoming an ESOL tutor, and we are also hiking, going to book club and wine tastings, making new friends on the Cape, gardening, studying Italian, walking the beach almost every morning, and unpacking boxes still in our cellar from the move here last July." She would like to hear from Cornell friends **Ann Campbell** Capron, BArch '61, **Harry "Buzzy" Welch**, MBA '62, **John Sherrod**, and **Barney Hodges '57**.

Two years after her move from Rochester, NY, **Carol Sue Epstein** Hai writes from Lexington, MA, "I'm finally feeling like I am settled in here. I have a full and stimulating schedule of Tufts Osher courses, day trips with friends to visit museums in every direction, fitness and yoga classes, and great theatre, to name a few of the pursuits in my new life in Greater Boston." She says she was stunned to learn of the death of **Jill Weber**, whom she had run into once at an event and hoped to see more of. Jill spent most of her adult life in the Boston area, where she had a career as an architect and award-winning painter.

Arnold Henderson (El Cerrito, CA) continues his longtime project, web-publishing books of poetry and art photographs. The latest, his sixth, is a verse translation

of the comical fox stories found in the medieval *Romance of Renart*. Arnold says, "My wife, Natalie, is getting scientific about her gardening, while daughter Rachel is using her neuroscience PhD to set up as a consultant for biology education, doing web textbook work for national school programs." Attorney **Laurence Dornstein** (Beverly Hills, CA) is "still at work doing personal injury defense representing the Los Angeles County Metropolitan Transportation Authority." His other good news is that, after a cancer diagnosis, "with a great radiation oncologist and a new focused-radiation machine, I was completely cured, painlessly." Larry's wife, Judith, is also an attorney, and their daughter, Courtney, is now in San Francisco "doing experiential marketing." He would like to hear from old Cornell friend **Monroe Karetzky '59**, MD '63. Again, send me news. ❖ **Judy Bryant Wittenberg**, jw275@cornell.edu.

61 All of us have received the sad news of **Peter Kessler**, my predecessor as class correspondent, sent me the following note. "Even in a Cornell class whose members have made huge contributions to creating a university we are all so proud of, Peter was a giant. He had great love for Cornell. His legacy will live on through the School of Biomedical Engineering, his achievements as chairman of the Board of Trustees, and the many other ways in which he and **Nancy (Schlegel) '62** have left their marks. This news arrives just a day after the *WSJ's* special section on US College Rankings was published, ranking Cornell among the top ten for the first time. Sincere condolences to Nancy and his family." I believe David's thoughts reflect our remembrance of Peter's contributions to Cornell. A memorial ceremony was held in Aspen, CO, on October 28. A group of Peter's fraternity brothers and fellow golfers were in attendance including: **Jack Neafsey**, MBA '63, **Phil Hodges**, **Peter Whiskeman**, **Warren Spicka**, **Robin Bissell**, **Dick Tatlow**, **Doug Uhler**, **John Sobke**, **Ken Blanchard**, PhD '67, and **Charles "Chubb" Lee**, who gave the eulogy.

The somber tone of this column continues. Our classmate **Janet Ballantyne**, PhD '76, a retired foreign service officer at the Agency for Int'l Development (USAID), died in Bethesda, MD, on August 30 after a months-long illness. She was 78 years old and lived for many years in Chevy Chase West. She received a master's degree in public administration from Syracuse U. in 1962, and a PhD in International Development from Cornell's School of Business and Public Administration in 1976. Janet spent 33 years with USAID, serving at Washington headquarters and in six country and regional programs: Peru, Nepal, Morocco, Nicaragua, Russia, and the Central Asian Republics. She was deputy mission director in Nepal and Morocco and mission director in Nicaragua, Russia, and the Central Asian Republics. In Washington, she served first as an economist in the Bureau for Latin America, and later as deputy assistant administrator in four bureaus. Following her last overseas tour, as USAID's principal representative in Moscow, she served two years as USAID professor at the National War College in Washington. Janet retired from USAID in 2002 with the rank of career minister. In 2007, she returned to USAID at the request of a new administrator, and served as senior deputy assistant administrator for Latin America and the Caribbean, retiring a second time in 2012. In 2016, she was recognized by USAID's administrator for a lifetime of service to the agency and the American people and extraordinary commitment to global development.

In August, **Robert Millman** passed away peacefully at home of a stroke. He was cremated, and his ashes were spread over his property in Vermont. He leaves three children: Jenna, a producer with ABC, Daria, and **Lucas Millman '18**, a rising senior at Cornell. **Peter Greenberg**, our past class president, sent along the following note: "Bob was a respected psychiatrist with connections to organized baseball and athletes with drug and alcohol related problems (i.e., Darryl Strawberry). His practice was in NYC, and he taught at the Cornell med school for a time. He also had the bad fortune of being my roommate for our junior and senior years at Cornell."

Here's an update from former class president **Diane Baillet Meakem** (Dbmeakem@aol.com), who wrote, "I'm living in Jupiter, FL, seven months of the year and Connecticut the remaining five after being widowed four years ago. But I take great satisfaction having five married children and 16 grandchildren." **Dale '59**, LLB '63, and **Jane Van Wynen Goodfriend** returned to England with their children and spouses, and their children, to celebrate a 50th wedding anniversary in July 2015. After a week at a house in Somerset and a week in a 16th-century house in Middleton, North Yorkshire, they revisited the Grange in Lastingham for a high tea. All 18 enjoyed a classic English tea where Jane and Dale had dined nightly during their vacations in 1970 and 1973 with Jane's parents, Grace and **Kenneth G. Van Wynen 1925**. They also entertained friends and former neighbors at their "local" pub in the village where they resided from 1977-81 before they traveled to Yorkshire.

With the recent airing of "The Vietnam War" on PBS, we have further interview comments from **Gus Kappler**, MD '65, who served as an Army trauma surgeon at the 85th Evacuation Hospital in Phu Bai, Vietnam, from 1970-71. His one word to describe Vietnam: "life-altering." He says, "I witnessed firsthand the devastation of war on body, mind, and soul. I would have not chosen to abandon my wife and children to serve in Vietnam, but the Army controlled my destiny and I did go. However, that year became the most influential determinant in the development of how I engaged and interacted with my wife, my children, my friends, my patients, and society."

I am writing this column on a beautiful fall day, and wish the content was more optimistic. My wife, Susan, and I just completed a Canadian cruise on the *Queen Mary 2*. Not exactly a demanding journey, but we continue to travel as good health and curiosity permit. Please send all your news, and particularly your GOOD news, to us. Keep your notes and e-mails coming. ❖ **Doug Fuss**, dougout@attglobal.net; **Susan Williams** Stevens, sastevens61@gmail.com.

62 Happy and healthy New Year to all! Do start the New Year by sending a note of your news to your classmates via this column.

Al Leitch (alleitch@moore.sc.com) "really enjoyed seeing everyone at our June Reunion." (As you turn your calendar to a new year, save the dates of June 9-12, 2022 for our 60th!) Al has become an artist since retiring from academia. He and Carol live in Lexington, NC. A number of our classmates were in Ithaca in October to honor the coach who led our freshman class crew team to an undefeated season and national championship in 1959. **Carl Ullrich '50** received the prestigious **Whitey Mullestein '32** Leadership Award. Coach Ullrich is only the seventh recipient of this award. Attending the dinner were **Gary Brayshaw**, **Vic Ericson**,

Warren Icke, Fred Hart, Tom Hoard, John Neuman, Dave Nisbet, Steve Peterson, BArch '65, Chuck Schmid, Bob Simpson, and William "Wick" Walters.

"Decided to give up snow and cold and moved to Vero Beach, FL," wrote **Stanley Kozareski** (kozareski@gmail.com). "So far it has been wonderful. We have escaped the hurricanes." The Kozareskis enjoy reading and dining with friends. Also making a move were **Steve** and **Deb Schmal** (schmals@verizon.net), who went from Chevy Chase, MD, to San Diego, CA. They enjoy volunteering and look forward to more travel time.

Several classmates participated in Cornell's Adult University in 2017. **Samuel '61**, MD '66, and **Judith Shapiro Greenblatt** studied architecture. **Otto Doering III**, PhD '73, participated in Choral Musicianship. **George Loveless**, MBA '63, learned about the Death of the Roman Republic while **Shirley (Morrison) '63** took up Sharia law. Jewish American Experience drew **Paul '59** and **Lynn Blumstein Morris** and **Michael** and **Linda Miller. Ronald Stiff** spent a weekend inside the Smithsonian. **Pete** and **Ruth Zimmerman** Bleyler enjoyed a weekend of theater in New York City. There's something for everyone at CAU!

Michael Ernstoff, MS '65 (ps144nyc@yahoo.com) in Los Angeles is "still working to prove to myself that I'm not yet ready for the rocking chair. Google the YouTube video 'Senior Citizen Windsurfing Update' or go to: <https://www.dropbox.com/s/ff8ixwrhdtzgd/MEjibe%20good.wmv?dl=0>." **Fred Luper** (fluper@lnlattorneys.com) also suggests a YouTube video for you to see. He just completed performing as Arvide Abernathy in *Guys and Dolls*. Arvide sings the beautiful "More I Cannot Wish You" to Sister Sara. "That song is very special to me because it is the song my daughter (Judge Betsy Luper Schuster) walked down the aisle to at her all-Broadway wedding (all the songs were Broadway love songs). I still practice law every day with the firm I founded 50 years ago, on May 1, 1968. My wife, **Carol (Perlmutter) '64**, celebrated four years of retirement as a TV news reporter for 35 years. Her retirement video tribute can be found on YouTube ('Carol Luper Retirement Video')." Carol and Fred are in Columbus, OH.

Sad news to report of the passing of **Willis Ritter** of Washington, DC, last September after a long battle with Parkinson's. After Cornell, Willis graduated from the U. of Virginia School of Law, where he made law review, before embarking on a pioneering and highly successful career in the practice of municipal bond law. He and Anne have three children and seven grandchildren. Willis was "an avid golfer, raconteur extraordinaire, and long-suffering Redskins fan." ♦ **Jan McClayton** Crites, jmc50@cornell.edu.

63 By the time you read this, winter will be settling in wherever you are. Our 55th Reunion will also be six months away—don't forget to respond to Reunion mailings. The dates are June 7-10, 2018.

Harold Nathan writes from NYC that he is busy in his law practice, mostly buying and selling companies for clients based in Asia. "I'm also working with Nomi Network, pro bono, in their project to assist abused women in Southeast Asia to obtain skills necessary to make products for distribution and sale in the US and Europe. Nomi Network is named after a Cambodian girl who was one of the first they rescued and has gone on to become an inspiration for others." **Joseph Lamendola** (Watertown, NY) sent news of the death of his wife, Janet, after 33 years of marriage. She passed away in January 2017 of an unexpected heart attack. "Fortunately, we

were remarried in the Catholic Church on September 23, 2016," he writes.

Yunus Aslan now lives in London and is a member of the Cornell Club there. He has many social activities that keep him busy in London and he enjoys spending time with his three grandchildren, playing sports, and visiting his students who are now businessmen. "I am the honorary president of Turkish Hotel, Restaurant and Tourism Assn. in the UK. I go to my grandchildren and daughter on the weekends and take my grandson, 11, to football training regularly." When asked if there was anything else he wished he could be doing, Yunus said, "A lot more—being more active, working, teaching, social activities, sports, and so on." At Cornell, all his teachers, including Rudolf Munster, and friends and classmates had the greatest impact on him.

Cornell and **Alice Dawson** live in Bomoseen, VT. In March, they spent a month in Orlando, FL, enjoying family, friends, and the weather. Following that, they flew to Europe for a two-week Viking River Cruise through Europe. Fred and **Wendy Oldfield** Kahn (Palo Alto, CA) keep busy. Wendy "still tutors ESL part time. Having lived in Japan years ago, I love keeping up with my students' lives and the changes in their Asian countries! Our kids visited Cuba and loved it—came home with an organic Cuban cigar for Fred. We visited Iceland and drove around the island—a challenge? Stayed in farmers' B&Bs and saw puffins." Wendy recently touched base with **Marcia Beiley** Laris, who also lives in Palo Alto. She adds, "I wish I could see more of my Cornell friends like **Eugenia "Genie" Barton**. Also, **Clinton Rossiter '39**'s course on the American presidency had a great impact on me."

Channing Jones and his wife were busy visiting five European countries in 2017: the Netherlands, Belgium, France, Ireland, and the Czech Republic. "In April, we flew to Amsterdam for a week, primarily to visit the tulip gardens in Keukenhof. Then we took the high-speed train to the beautiful city of Bruges (Brugge in Dutch), Belgium. Following three days there, we took another high-speed train to Paris to see our granddaughter **Emily Jones '18**, who was taking a semester away from Cornell at the U. of Paris. There we enjoyed going to Versailles, Giverny, and several museums. We especially remember stopping at Angelina Tea House, near the Louvre, to sip their almost pudding-like hot chocolate (chocolat à l'afraicain) and eat French onion soup and pastries. In July and August, we initially spent ten days in Ireland with six friends from South Carolina. We visited the Rock of Cashel, Blarney Castle, the Ring of Dingle, Ross Castle, the Ring of Kerry, and the Cliffs of Moher. We also played links golf at the Dooks Golf Club and stopped at the Malton Hotel in Killarney for high tea. On July 31, we flew to Prague, in Czechia, where we observed the medieval astronomical clock, many beautiful churches, and Prague Castle. We took a three-hour trip to the Bohemian town of Český Krumlov and, on another day, a train ride to Kutná Hora to see, among other sites, Sedlec Ossuary, a chapel adorned with human skeletons. We truly enjoy walking around the towns in the places we visit and especially talking with folks that live in those parts of the world to hear their thoughts regarding their interests and concerns within the political and economic climate in which we live today."

Joel Sobo writes from West Orange, NJ, that he and his wife, Elizabeth, "visited San Francisco and had dinner with classmates **Dean Edell**, MD '67, **Marilyn Kahn** Kessler, **Ellen Grau** Filler, and their spouses. Spent a day with roommate **Peter Nussbaum** and his wife, Aleta.

Great to see all after so many years." Remember our 55th Reunion, June 7-10, 2018, and please e-mail me with your news. ♦ **Nancy Bierds** Icke, 12350 E. Roger Rd., Tucson, AZ 85749; e-mail, ick63@gmail.com. Class website, cornellclassof1963.alumni.cornell.edu.

64 An interesting variety of news this month, from memories of being a weatherman at a particularly grueling time in a war, to being formally honored for multiple times weathering a particularly grueling race.

Long-distance runner **John Cederholm** was inducted into the Mount Washington Road Race Hall of Fame last June for his many accomplishments in the legendary race up the menacing peak in New Hampshire—from being first in his initial attempt in 1973 to recently placing third in his 35th running of the race, this time in the 70-74 age group, a seniority cohort he has won twice and placed second in twice. The race course is just 7.6 miles long, not that far for a lifelong runner like John—he's also run 26 marathons—but it rises 4,700 feet from the base of the auto road to the summit at an average ascent angle of 13 percent! John catches his wind back home in Marion, MA.

Kenneth Kupchak, JD '71, was a weatherman—specifically, a meteorologist to General William Westmoreland—for a time during the Vietnam War. Ken was a "weather guesser" (his term) for the US Seventh Air Force, and the commanding officer's weather G-2 (intelligence officer) during the critical Khe Sanh and Tet Offensive campaigns. Ken's exploits were featured on "Think Tech Hawaii," a live-streaming TV service that featured a series of interviews with Vietnam vets in conjunction with documentarian Ken Burns's PBS series on the war. Ken Kupchak writes of his experience, "I was in-country during Tet and was briefing 'Westy' daily during that period. His focus was totally on Khe Sanh. He asked me if he could burn a 15-mile circle out of the forest around it with napalm. We said unlikely, due to high moisture content in the jungle. He accomplished it, sort of, with B-52 raids that made it look like the back side of the moon, what with all the craters. Downside: NVA now had overlapping fox holes all the way to the perimeter." Here is a link to Ken's interview: <https://www.youtube.com/watch?v=RkVi6k4gElo&t=5s>. Ken and wife **Patty (Geer) '67** live on Oahu, where the weather is never not delightful.

Thomas Mueller, ME '66, has moved from Reston, VA, to a rental property near where one of his two sons lives in Raleigh, NC. While in the Washington, DC, area for many years, Tom devoted most of his spare time to Thoroughbred horse racing, including owning horses through syndicates, plus pari-mutuel betting. (His first rule of betting: "Do not bet at random!") Tom goes on to say that, in his best betting year, he collected 25 percent more than he laid out. Tom also bet according to sheaves of statistics, ranging from gauging the performance of gelded male horses based upon their age at being gelded, to calibration of racetrack conditions. After working for the US Navy for many years, Tom retired when the Soviet Union collapsed to enjoy life being a grandfather of five, playing bridge, reading, and doing genealogical research. He would like to hear from classmates now that he's settled in his new apartment.

Elaine Emling, MA '69, MRP '83, keeps busy with an extensive garden, plus she's active in local and national politics, most recently as a self-designated lightning rod for a major light rail transit line to be built near where she lives in Silver Spring, MD, with husband Mike Jenner.

Getting a chance to use her Cornell degree in urban planning, Elaine is coordinating a small neighborhood group that will both field complaints and provide support during the line's five-year construction, which will include a tunnel just a block from their home. In her spare time, she's trying to read all the books purchased years ago. Elaine also writes that she's now a step-grandmother to a "charmer of a chap" from Galway, Ireland.

Stephen Crawford (Derwood, MD) is also keeping busy working, in his case part time as a research professor at George Washington U. Inst. of Public Policy. There, he's "winding up a major project, which has evolved into Credential Engine, a new nonprofit with its own board, staff, etc." Steve's also doing research, writing, and consulting on education, economic and workforce developments, and social mobility. He also plays tennis three times weekly, but would like more time for reading, travel, volunteering, and visiting with old friends. Steve, wife Liliane, and their daughter (adopted from Vietnam in 2001, and entered college this past fall) visited her birth family outside Hanoi last summer—"Quite something for this Vietnam War vet," says Steve.

Jerome Rubin (Carmel, CA) writes that not only is he not yet retired, but his hematology-oncology practice is busier than ever! Fortunately, he's one of six physicians—daughter Nancy is another—in the cancer-specialty practice. In his spare time, Jerry works out at a nearby gym, plays tennis with Nancy's two children, and travels with wife **Suellen (Safir) '65**, recently to Glacier National Park and Israel. **Lois Beach Conrad**, MEd '65, has kept busy, traveling abroad with husband **John '63**, MS '69, on mission projects with the Christian Broadcast Network (CBN). The Conrads have recently been to South Africa and Ukraine, plus Israel and Thailand, where they worked with orphans. They also visited China with 14 students, where they saw seven cities in 16 days. And if that wasn't enough, Lois and Jack on their own returned recently from visiting with a niece and the family of a former student in Australia, plus they also took a cruise to New Zealand. On a darker note, Lois writes that she was recently diagnosed with Alzheimer's, so "we are doing what we can do in the time we have to do it."

That's it for now. Please don't forget to send your news to me. ♦ **Bev Johns Lamont**, 720 Chestnut St., Deerfield, IL 60015; e-mail, blamont64@comcast.net. Class website, www.cornell1964.org. Class Facebook page, <https://www.facebook.com/groups/cornell1964>.

65 There is an old adage that "no news is good news." That may be so, but we suspect many more members of the Cornell Centennial Class have affirmative good news to share with us in greater numbers. People love to hear from you—send in your news!

First and foremost, we offer kudos to **Neena Martin** Lurvey (Estero, FL; nlurvey1@gmail.com), who served four days and nights as a Red Cross volunteer at Germain Arena with over 6,000 people sheltered from Hurricane Irma. She was grateful that her own home stayed basically intact notwithstanding the storm. **Joan Hens** Johnson can happily report that she and numerous other classmates who have Florida residences similarly did not suffer any significant damage from the hurricane. Joan got to spend a delightful September in Paris, taking in the culture and beauty of the city.

Al Center, ME '66 (Ithaca, NY) is not only still in Ithaca with wife **Ingrid (Berlin) '66**, but is still at Cornell, teaching Chemical Engineering topics that help students make the transition from engineering science to engineering applications. He has been doing this since

1999 and it has yet to lose its allure. He was appointed as the first professor of practice in the College of Engineering several years ago and is the associate director of the Master of Engineering program. Al derives satisfaction from his children's accomplishments; he and his family are understandably very proud of his son's work as a volunteer firefighter during and after Hurricane Harvey. He also enjoys having former students report new life events, either by e-mail or by dropping in to say hello when they are on campus.

Stephen Hand (Ithaca, NY; shand35@gmail.com), our reliable class webmaster, considers himself fortunate to live a short (20-minute) walk from Schoellkopf Field and Lynah Rink, as well as to have five of his six grandchildren residing in Ithaca as well. As of the past fall, he

beloved Joe, has been conferred for outstanding contributions in the victorious football game against Harvard on October 7. The recipient was **David D'Amelio '19**. Send news to: ♦ **Stephen Appell**, bigred1965@aol.com; **Joan Hens** Johnson, joanipat@gmail.com.

66 My deepest apologies to **Arnold Berger**, PhD '71, for confusing him with classmate **Andrew Berger**, JD '69, in the September/October column. Apologies also to Andrew. Here again is the news from Arnold: Arnold Berger (aberger@uw.edu) reports from Sammamish, WA, that he has finished a three-year term as a department chair and returned to being a "whining" faculty member in the division of engineering and mathematics at the U. of Washington,

'Kenneth Kupchak was a "weather guesser" for a time during the Vietnam War.'

BEV JOHNS LAMONT '64

was all set for yet another season of men's and women's hockey, indisputably his favorite Cornell sport. On August 21, he viewed the total solar eclipse from Andrews, NC, with his son Chris and Chris's girlfriend, Savannah. He recommends such an event for everyone's bucket list. He notes that the next chance in the US will be April 8, 2024, on a path from Texas to Maine, which will include Buffalo, Rochester, and the north end of Cayuga Lake! Steve further notes that on May 23, he bade a fond farewell to Sandy, Mike, and Jackie of the Kuntz family at the bittersweet closing of Hal's Deli on Aurora Street. Hal's had been a popular downtown eatery since 1961. The family members have been major supporters of Cornell basketball through the years. Hal Kuntz was the scoreboard operator at men's games for a quarter-century (his son Mike has since served in that capacity).

Janet White Gibbens (Cavendish, Victoria, Australia; jwgibbens2@yahoo.com) relates, "I'm retired from the science laboratory in California, London, and Melbourne, and am living back and forth between the Grampians in Western Victoria and a village on the Great Ocean Road, where I can visit my grandson, now 2 years old. Am trying to keep the knee joints oiled and read some books. Just paid my dues and hope to hear news from Cornell. There is an Ivy group that meets in Melbourne, but I'm too far away." Janet fondly remembers her long-time friend and classmate **Marjorie Rubin** Brody, who was the first person she met in her freshman dorm corridor at Cornell. She still thinks on a day she visited Ithaca several years ago with her brothers, **Bob White '64** and **Andy White '69**, and they had a pleasant stroll from the south campus to the Dairy Bar.

Stephen Appell (Brooklyn, NY; bigred1965@aol.com) is still teaching his course on significant presidential elections at Brooklyn Lifelong Learning, the retirees' education program located at Brooklyn College. This academic year he is concentrating on the Johnson-Goldwater election of 1964, the one presidential election that occurred during our Cornell undergraduate years. Lastly, we are proud to note that the first annual **Joseph E. Ryan** Offensive Lineman Award, in memory of our

Bothell. Teaching, research, and scholarship are still his passion and he hopes to continue as long as possible. This academic year he will be on sabbatical at the U. of Sydney, Australia. He cites Prof. R.W. Balluffi, his PhD advisor, as the Cornell person who had the greatest impact on him.

John Richert reports that he and his wife, Nancy, have both retired from Biogen and have moved back to the D.C. area from Cambridge, MA. John is doing some consulting and investing, mostly with startups. He reports that the two companies farthest along are Digital Cognition Technologies (<http://digitalcogtech.com/>) and Honor My Decisions (<http://honormydecisions.com/>). John and Nancy also spend lots of time at their place on Pawleys Island, SC.

Garry Munson is still working full time. His daughter is a freshman at Notre Dame. He keeps in touch with the Cornell '60s hoops players. Class co-president **John Monroe**, PhD '70 (monroe.jw@gmail.com) continues his interest in music, playing the euphonium and the trombone. He recently played in an ensemble with teaching by Tony Clements, then took a master class at Stanford with great teaching by Michael Mulcahy of the Chicago Symphony. He balances this and other music ventures with attendance at football games at Stanford. In September, John and **Meg (Warne), MS '68**, sailed with Viking from Bergen, Norway, to Montreal, Quebec, via the Faroe Islands, Iceland, Greenland, and Newfoundland. Bergen turned out to be a great place to shop for brass band sheet music. John has been in touch with **Pete Leech**, who has made a courageous recovery from his second bout of cancer. Pete's extremely grateful for the strong support of his Phi Psi fraternity brothers, especially **Bill Robinson**. John also reports he's been enjoying seeing **Larry Mohr** for the occasional lunch in Menlo Park, CA. Last spring, **Jack MacDonough** came to visit Larry, and John acted as chauffeur driving Larry and Jack to their favorite haunts from their Stanford business school days.

Check out the class website for **Roger Burnell's** photos of the Cornell Tech grand opening this past

September. Roger and wife Joelle had a grand time at the ribbon cutting, where they announced the “Roger and Joelle Burnell Chair in Technology and Integrative Medicine” at Cornell Tech. Our other class co-president, **Rolf Frantz**, ME '67 (nrfrantz@verizon.net) reports that he and wife **Nancy (Nystrom) '68** spent a pleasant weekend on campus in early October. Nancy's 50th

patient visits a year and a \$12 million annual budget by the time she retired 40 years later. The Yale School of Public Health awarded her its Distinguished Alumni Award in 2013. She served as a lecturer at the school and on the boards of local and statewide public health organizations. A memorial service will be held in New Haven this fall.” More information about the Katrina

where I enjoy organic gardening, cooking, and food preserving. My only child, Heidi, lives in Walnut Creek, CA, and has a successful career as an admin professional. We get together whenever we can.” Karen adds that she gets the most satisfaction from “helping others awaken to their spiritual potential—their ability to manage thoughts and feelings to achieve an elevated consciousness that is self-empowering and non-reactive, and gives benefit to self and others rather than taking sorrow. Would love to hear from anyone who might remember me.”

Peter Buchsbaum (Stockton, NJ; pbuchsbaum@aol.com) writes, “The Reunion exceeded all expectations. Thanks so much to the organizers. Meanwhile, I have just agreed to co-chair a new planned giving committee of the World Union for Progressive Judaism. If anyone has ideas/advice on doing this, please e-mail me. I can use the help. Otherwise, spending summers at our island home off the Maine coast near Acadia, volunteering in Israel, writing on a variety of issues, and trying to learn Hebrew. I can report that my language skills have not improved in 50 years.”

Butzel Long, a Detroit-based law firm, announced that **Leslie Alan Glick**, JD '70, an international trade and customs law attorney, has become a shareholder in the firm's Washington office. He has handled major international trade cases and unfair trade practice investigations, and has been active in lobbying on trade matters for companies in the automotive and food industries, as well as others. Les also assists US and foreign clients with compliance with laws and regulations of the FDA and USDA in relation to food products, meat and poultry, plants, medical devices, and the importation of pharmaceutical and biological materials, as well as consumer product safety and automotive product regulation and recalls. He has been an adjunct professor of law at the George Mason U. Law School and the U. of Baltimore. ♦ **Richard Hoffman**, 2925 28th St. NW, Washington, DC 20008; e-mail, derhoff@yahoo.com.

‘I can report that my language skills have not improved in 50 years.’

PETER BUCHSBAUM '67

Reunion is this coming June, and Rolf especially enjoyed visiting Bethe House and some of the dining venues from our 50th. They brought back great memories of the weekend one and a half years ago.

Cory Byard, MPA '74, posted a comment that shows why our relationship with current students is so special. Magic Cornell Moment, October 18, 2017: “While **Linda (Chesman) '68**, BS '70, and I were walking in front of Bailey Hall to a lecture in Kennedy Hall, we saw dozens of students forming a circle on the plaza. I made some stupid comment that it looked like a ‘Kumbaya’ moment. Then the students linked arms and began singing the ‘Evening Song.’ Linda and I stood transfixed by the moment, arms around each other, swaying in time to the music. It must have been the Glee Club, and for us, a very special moment. We were walking from a special Class of '66 dinner at Carl Becker House, where I had exclaimed that Cornell students fed my optimism that things were going to be better in the future. So true.”

Now that many of you are retired, what activities are you involved in? Do you travel, volunteer, take classes in subjects you had no time for before? Have you ever attended Cornell's Adult University? This past summer a number of classmates did. **Andrew** and **Andrea Riger Potash** attended the Spring Theater weekend. **Donna Amariglio** and **John**, BS '73, MS '76, and **Linda Blair Coulter**, MA '67, studied Sharia: The Origins and Workings of Islamic Law. **Nancy Hoffman** and **Jerilynn Hoy** studied the American Jewish Experience. Let us know what you have been doing. ♦ **Susan Rockford** Bittker, ladyscienc@aol.com; **Pete Salinger**, PeterSalinger95@gmail.com; **Deanne Gebel** Gitner, Deanne.Gitner@gmail.com.

67 Lynne Shavelson Joiner (Sonoma, CA; lynne_joiner@gmail.com) writes, “After attending our 50th Reunion in June, my dear friend and DG sorority sister, great humanitarian/public health icon **Katrina Clark** returned to her home in New Haven, CT, and five days later was rushed to the ER for emergency surgery. Surgeons discovered ‘Trientje’ (her Dutch nickname) had pancreatic cancer. Nine weeks later, she died at home surrounded by family on August 25, 2017.

“In her too-short, well-lived life, Trientje launched a career in public health as a Peace Corps volunteer in Colombia, working to improve living conditions by bringing fresh water to rural communities, and received the Peace Corps 25th Anniversary Sargent Shriver Award in 1986. She received a master's in public health from Yale U. and started the Fair Haven Clinic with a \$5,000 budget. It became a multi-site institution with 165,000

Clark Fund can be found at: <http://www.cfgnh.org/UnderstandingOurRegion/ViewArticle/tabid/161/ArticleId/1567/Katrina-Clark-Fund.aspx>.

Larry Eisen '66, ME '67 (Hackensack, NJ; fipublish@aol.com) reports, “My wife, **Marsha (Beirach)**, recently received the Jefferson National Award for Public Service. After retiring from her career as a dietician, she was left with a lot of free time. Following Cornell tradition, she looked for community service opportunities and found three that fit her interests. She teaches computer skills to seniors so they may keep in touch with their families all over the country. She drives the elderly and disabled to doctors' appointments or any other location they request. And she is a volunteer dietician at the Bergen Volunteer Medical Initiative, an organization that provides free medical care to employed individuals who get no insurance benefits. This was the activity for which she was recognized. The awards were personally presented by our governor at a state ceremony. She minimizes her efforts, but I am very proud of her devotion to the community.”

Cornell's Adult University listed a few of our classmates as attending either a summer class or a study tour. **Susan Dollinger** (Mexico City, Mexico; sbdollinger@aol.com) went on a study tour to Cuba and learned about the “renewed relations” between Havana and Washington. **Larry Matlack** (Washington, DC; lmatlack2@verizon.net) took Sharia: The Origins and Workings of Islamic Law on campus with wife Linda. And **Arnold Siegel** (arnold.siegel@gmail.com) took the Arts and Crafts Movement in Upstate New York with his wife, Susan Futterman.

Charles Sheppard (Springfield, MO; chucksheppard7@hotmail.com) is working for a “great helicopter air ambulance service, Mercy Life Line, and serving on the board of the Air Medical Physicians Assn. I have four great-grandkids and am still working full time and raising miniature horses. Last year I was honored to win the R.R. Hannas Award from the Missouri Chapter of the American College of Emergency Physicians.” Given a free day in Ithaca, he says, “I'd go and admire the gorges or maybe talk to somebody in the Engineering college about all the cool stuff.”

Karen Smith Coyote (Eugene, OR; bkkiran@msn.com) writes, “I am retired and living like a nun, administering a meditation center in Eugene. The center belongs to the Brahma Kumaris World Spiritual Organization, which is a worldwide network of centers in over 130 countries. I teach meditation classes, travel, and speak on/write about personal development topics related to spirituality. Since 2001, I've lived in wonderful Oregon,

68 Bob and Bette Nelson Zippin (cuin2018@gmail.com), the hardest working Reunion chairs ever, want our class—the best graduating class of the last two of the '60s—to have the most enjoyable and memorable 50th Reunion possible, June 7-10, 2018. Feedback from their surveys confirms that the turnout will be the biggest in the history of turnouts, and that our class HQ in the Hans Bethe House on West Campus is the most convenient and comfortable for our celebration, which begins Thursday afternoon and continues through Sunday brunch. There will be tours of the campus, a class forum, and lots of food and drinks throughout the weekend as our beloved campus provides the most nostalgic backdrop for connecting and reconnecting with classmates. If the Zippins have your e-mail address, you've been receiving monthly updates, which are also posted on our Facebook group (<https://www.facebook.com/groups/1874606986086430>) and our class website (<http://classof68.alumni.cornell.edu>). Please contact Bette and Bob with any questions, information, or suggestions.

When **Elliot Meisel** (emeisel@msn.com) and his wife, Mimi, arrive on campus for our 50th, it will also mark 66 years since he first attended a Cornell Reunion. That time it was his mother's 10th Reunion, but his Cornell legacy goes back even further to his great-uncle **Louis Koenig 1906** and includes his father, **Sidney Meisel '37**, and, to his delight, continued with his daughter, **Sara Meisel Tranter '02**, and her husband, **Mike**

'02. Including uncles, aunts, cousins, and their spouses, Elliot's family numbers over 40 Cornellians. In his maternal grandparents' honor, his family endowed the Moak Print Room at the Johnson Museum, and in honor of his parents they endowed the Grace Moak Meisel Internship in Asian Art and the Sidney Meisel Rare Book Preservation Fund. Having served on the Cornell Library Advisory Committee for many years, Elliot believes that, along with his familial bonds, Cornell has few, if any, equals in fulfilling Ezra Cornell's aspiration to provide education in all subjects for its students' Aristotelian pursuit of deep knowledge without sacrificing a well-rounded life. For his 50th Reunion, Elliot is endowing the Meisel Family Reading Room in Olin Library, and he encourages others who are able to consider a Tower Club level gift to some area of Cornell that enriched their lives. In the meantime, Elliot still enjoys managing his law firm, serving on the Sagaponack Zoning Board of Appeals, and piloting his small Cessna.

Last year, **Bill De Cou** (billdecou@bigsky.net) generously made a sizable contribution to Cornell. In addition to the satisfaction of giving for Cornell's future, he points out the tax advantage of gifting. Bill sold a residential rental property and donated to Cornell through a charitable remainder trust, which enabled him to avoid an immediate capital gains tax. It also provided him with both a sizable deduction that he was able to use to offset the capital gains on other properties he sold, and a fixed income for life based on his age (5 percent at age 70), or a variable amount if any part of the trust is invested in the stock market. Like Elliot, Bill is challenging classmates to make similar donations. We applaud all those whose gifts to Cornell help to assure that a quality college experience will endure above Cayuga's waters for future generations.

David Weisbrod (david.a.weisbrod@gmail.com) and his wife, **Margaret (Simon) '66**, live in Greenwich CT, where David will be on the ballot this November as the Democratic nominee for the Board of Estimate and Taxation. David serves on a couple of corporate boards, but the current joy of his life is his adorable 2-year-old grandchild, Timmy. **Elaine Elinson** (eelinson@gmail.com) lives in San Francisco, CA, where she has been recognized by City Lights Bookstore in the "Pedagogies of Resistance" category for her book *Wherever There's a Fight*, which she coauthored with Stan Yogi. Her book addresses what she feels is the current environment of rising repression and the urgent need for action.

Pete Smith, JD '71 (PGSmith3061@gmail.com) and his wife, **Debbie (Kates), MA '71**, divide their time between their homes in Naples, FL, and Long Beach Island, NJ, and stays in NYC, departing from that routine every five years to join us at Reunion. **Charles Darwin Hepburn** occupies his time contemplating the vast study of theoretical physics and enjoying music. He pays tribute to Dr. Hans Bethe (Nobel Laureate) as the professor who had the greatest impact on him during his Cornell years. Send news to: ❖ **Chuck Levitan**, clevitan22@comcast.net.

69 Happy New Year to all! Hope you enjoyed the holidays. We here in the Northeast are girding our loins for what promises to be a cold and snowy winter according to the *Farmer's Almanac*.

The following classmates attended CAU programs in 2017: **Carolyn Ugiss** Altieri, **Sandra Schroeder** Bricker, **Suzanne Backiel** Harley, **Ted Hudson**, **Nancy Karch**, **James McCormick**, ME '70, **John Reilly**, **Michael Waxman**, **Janet West** Wood, and **Bruce Yukelson**.

For more information on their myriad trips and programs on campus, go to www.cau.cornell.edu.

David Halpert has spent the last 15 years in Santa Monica, "after leaving Manhattan after luckily dodging 9/11," he writes. "Every year I live is a bonus, having left the 105th floor company of One World Trade Center after ten years in April 2001." He enjoys the Cornell Club in Southern California and still does interviewing. Like most of us, he thinks it's hard to believe it's been almost 50 years since we graduated. **Lee Pillsbury** and wife Mary were on Roosevelt Island for the dedication of the first phase of Cornell's new tech campus. "What a great moment and what a great future it holds for Cornell. Meanwhile, back in Ithaca, the board of trustees has approved a plan to bring 2,000 additional beds to North Campus student dorms. This will change the undergraduate experience at Cornell and address the long-standing housing shortage!"

Susan Wohryzek Mittler was elected a New York Board of Regent for the 6th Judicial District, which covers ten counties, including Tompkins. As a Regent, she is working on the state level for the betterment of educational practices for all children. Daughter **Jessica Mittler '94** is an associate professor at VCU in Richmond, VA, and son **Craig Mittler '98** has moved to Chatham, NJ. Susan is teaching a class in the ILR school in collective bargaining, donating her time. Living in Ithaca, she says she "would wander around the campus just for the pleasure of seeing all the new buildings and spending time in the library . . . if I didn't have to fight for parking." We remember the parking problem all too well. **Patricia Stahl** is in Dallas, still in private practice specializing in anxiety disorders. "Trying to make hay while the sun shines," she and husband Chet are doing lots of traveling and looking to move closer to their sons in California at some point. She would love to hear from her freshman roommate, **Jacqui Stark**.

Log on to our class website at www.cornell69.org to find out about the Class of '69 scholarships available to family members of classmates. Don't forget to save the date for our 50th Reunion, June 6-9, 2019. A Happy and Healthy 2018 to all! Please send your news and notes to: ❖ **Tina Economaki** Riedl, triedl048@gmail.com.

70 A new day and a new year, 2018! When we were all thinking (and perhaps worrying, too) about the New Millennium, I was not imagining how swiftly the following 18 years would go by. We are now two and a half years until our 50th Reunion at Cornell. Now, that is amazing! So often, these days, I seem to feel and see the signs that our time on the Hill was so long ago. However, at the same time, when I think of our undergraduate years, I can quickly be transformed back to a much younger version of myself—at least in my mind! Our 50th Reunion weekend is June 4-7, 2020. Please be sure to check out our various sites: class website, cornell70.org; Facebook page, www.facebook.com/Cornell70; and Twitter page, www.twitter.com/CornellClass70.

Classmate **Jomarie Alano**, MBA '82 (jma49@cornell.edu) has written and published a new book, *A Life of Resistance: Ada Prospero Marchesini Gobetti, 1902-1968*. Her book was published by University of Rochester/Boydell & Brewer. Ada Gobetti was a writer, translator, teacher, and women's rights activist who began her lifetime of resistance and her fight against fascism in the early 1920s. She organized other Italian women (whom she viewed as a political force) against German occupiers and fascist oppressors. Ada fought for the ideals

of grassroots democracy, women's rights, and democratic education for the rest of her life. In addition to writing, Jomarie is a visiting scholar at Cornell's Inst. for European Studies. She is also the translator and editor of Ada Gobetti's *Diario Partigiano*, which was published by Oxford University Press as: *Partisan Diary: A Woman's Life in the Italian Resistance*.

Barbara Spaid (bspaid17@gmail.com) reports that she has retired from the US Agency for Int'l Development, which is part of our Foreign Service. She is now living in New Hampshire with her husband. And yes, she still loves the snow! Barbara would like to hear from classmate **Leigh Rooney**, who was in Pi Beta Phi sorority. "Old" news from **Arthur Litowitz** (Edgewater, FL; arthur.litowitz@gmail.com), who is a retired orthodontist and presently a yoga teacher (RYT 200). Arthur enjoys travel, organic gardening, reading, guitar and piano music study, drawing and watercolor painting, and investment portfolio management for nonprofit organizations. He's also caring for his elderly parents, practicing and teaching yoga, doing meditation (specifically Vipassana), and participating in a photo club. What would Arthur rather be doing? He would like to pursue more creative activities, including composing music, doing creative writing (especially poetry and short stories), as well as memoir and autobiographical writing. He is very interested in writing and illustrating children's science nonfiction books. Two friends who Arthur would like to hear from are **Ernest "Chip" Reveal** and **Bob Berley**. Arthur has a great list of Cornell folks who had an impact on him at Cornell: Carl Sagan, Dan Berrigan, Hans Bethe, Robert Sienko, Jerome Zuckerman, Ernesta Cottrell, and Antoine Blackler.

Jeff Altamari (jeffaltamari@gmail.com) and wife Janet have been in Saratoga Springs, NY, since early 2015, after Jeff retired from Cameron Int'l in Houston, TX. Jeff has been appointed to and is serving on the Saratoga Springs Charter Review Commission. He is also treasurer of the mayor's re-election campaign and on the board of directors of the Opera Saratoga, and he was recently appointed to the board of Planned Parenthood. Janet and Jeff have been traveling extensively. However, they are now focusing their time, treasure, and talent on fighting Trump initiatives. Jeff has been in contact with '70 friends **Bill Todd**, MPA '72, of Margate City, NJ; **Bob Gartside**, ME '71, who lives in Brewster, MA; and **Larry Ward**, who is in Ithaca. Jeff wishes that they could all get together to mourn the death of **Emanuel "Gerry" DeFrait**, their friend and classmate. Jeff says that professors Robert Sienko and Charles Ackerman had the most impact on him at Cornell.

On September 17, 2017, **Patrick Kelly** and his wife, Angela, celebrated their 14th wedding anniversary and his 75th birthday. They did so by finishing the 10th annual Army Run 5K, and therefore receiving their 5K "dog tag" medals from a member of the Canadian Army. 23,000 runners from across Canada and the US competed in this annual 5-10K and half-marathon event. Patrick was an integral part of Cornell's Int'l Spirit of Zinck's Night celebration on October 19, 2017 at the Heart & Crown Irish Pub in Ottawa. It was the second Zinck's Night party for the Cornell Club of Eastern Ontario. Congrats on all of the above. Send news to: ❖ **Connie Ferris** Meyer, tel., (610) 256-3088; e-mail, cfm7@cornell.edu.

71 CALC is coming. That's right—Cornell's alumni leaders will once again gather in midwinter to plan events, share ideas, and learn more about what's

going on in Ithaca, New York City, and beyond. This year's event will be held in Philadelphia on February 1-3; for registration information and updates, go to: alumni.cornell.edu/volunteer/leadership/calcf/.

Our always active and involved classmate **Elizabeth Kaplan Boas** (ekb7@cornell.edu) writes to say that she's doing voluntary community leadership in Maryland and D.C. for Cornell-related work. Her husband, **Art Spitzer** (artspitzer@gmail.com), is legal director of the D.C. affiliate of the ACLU and "loves the mission and the work." They have enjoyed various CAU courses together in recent years, both on campus and off. "The kids continue with their lives," Elizabeth adds, "and we're proud of each one." She would like to hear from anyone who is in contact with **Mary Margaret Linberger**, who shared a Donlon double with her in 1968. Other classmates who attended CAU courses in 2017 include **Katherine Menton** Flaxman, **Jan Rothman**, **Bebe Oertel** Barbour, **John D'Addario**, **Catherine Kvaraceus** Hunter, **Marcia Wities** Orange, **Roberto Canizares**, MBA '74, **Cecily Dexter**, **David Schiff**, and **Theodore Urban**. For information about upcoming courses, go to: www.cau.cornell.edu.

John '70, MBA '71, JD '74, and **Amy Pastarnack Hughes**, MBA '74, live in Kings Point, NY. John, captain of the 1970 undefeated NCAA championship hockey team, practices law in NYC. Their son, **David Hughes '04**, resides in St. Petersburg, FL, and works at Merrill Lynch as a wealth manager. On September 2, 2017, their daughter, Olympic figure skater Emily Hughes, married Amit Mukherjee. Many Cornellians attended the wedding, which affords us the opportunity to catch up with classmates and friends from other classes. **Leslie Jennis** Obus is a retired attorney in NYC. Her husband, Michael, Justice of the New York State Supreme Court, New York County, officiated over the wedding ceremony. **Diane Brenner** is retired and lives in Palm Beach Gardens, FL. **Andrew Tisch**, former Cornell trustee and co-chair of Loews Corp., continues to be passionately involved in numerous philanthropic activities.

Also at the wedding was **Steve Gorfine**, who is a surgeon at Mount Sinai Hospital in NYC. **Michael Stone** (Fort Lauderdale, FL) is actively involved in the travel industry. **Linda Germaine**-Miller is a nutritionist, and her husband, **Joe Miller '69**, is a healthcare consultant. They live in the Boston area. **Richard Halpern** (Oyster Bay, NY) owns and operates gyms and training facilities across Long Island. **Larry Hughes '70**, uncle of the bride, lives and works in Portsmouth, NH, as an insurance executive. **Bob McGuinn '69**, a member of the 1967 Cornell NCAA championship hockey team, is happily retired and living in Toronto, ON. **Patty Stahl '69** (Dallas, TX) is a clinical social worker in private practice. **Leslie Abramson** Conason '69 is a retired attorney in NYC. **Scott Krahn '04** operates a beverage company that distills and distributes its own brand of gin, DHKrahn, along with many imported liqueurs. **Jennifer Pastarnack '04**, John and Amy's niece, is an attorney at Clifford Chance, specializing in banking and finance in NYC. And lastly, **Susan Kittenplan '85** is the president of the Skating Club of New York and lives in NYC.

Martha Coultrap (mfcoultrap@gmail.com) says that in March she had "a delightful trip to Mexico to **Maria Yurasek's** home with **Martha Hurd** Meredith, **Leslie Popoff**, and **Dara Prisant** Murray. Sun, beach, great food, and lots of laughs!" Martha is greatly enjoying spending time with her granddaughter, Eleanor, and sends best wishes to all classmates. **Richard Warshauer** (richard.m.warshauer@gmail.com) reports that

he was co-leader of a walking tour of Lower Manhattan on October 28, 2017. It was the 30th anniversary of the tour, called "The Great Crashes of Wall Street," which is sponsored by the Museum of American Finance. Let's hope they aren't recalling any more crashes on the next tour.

Congratulations to **John Allen** (jdallen@bsk.com). His law firm, Bond, Schoeneck & King PLLC, has announced that he was selected for inclusion in the *Best Lawyers in America*, the oldest and most respected peer-review publication in the legal profession. Lastly, a note of gratitude from **Arthur Mintz** and me, **Jim Roberts**, to all of our classmates, colleagues, friends, and members of the Lynah Faithful who have had kind words for our book, *Forever Faithful: Celebrating the Greatest Moments of Cornell Hockey*, published last fall by Cornell University Press (www.cornellpress.cornell.edu). Working on the book was a great experience for both of us, and the positive reception it has received is much appreciated. Let's Go Red!

Please remember to support our class and renew your CAM subscription by paying your dues. Send news to: ♦ **Jim Roberts**, jhr22@cornell.edu; or **Gayle Yeomans**, gay2@cornell.edu. Online news form, <https://alumni.cornell.edu/class-notes/>.

72 Jacqueline Davis Manigaulte received the 2017 National Urban Extension Leadership Award for her work with Cornell Cooperative Extension New York City (CUCENYC). Jackie, a senior Extension associate, leads family and youth development programs and serves as director of community relations for CUCENYC. She has worked with a wide range of NYC, state, and national organizations to provide youth and family programs that promote experiential learning, leadership development, and educational attainment and encourage healthy eating and active living. "Jackie had a vision of being a transformational educator when she was a Cornell undergraduate student, and she has lived by—and lived up to—that vision," said CUCENYC executive director Jennifer Tiffany.

Susan Farber Straus (Owings Mills, MD; sfstraus@icloud.com) continues to work as a clinical child psychologist in a residential diagnostic program for children who experienced trauma and have serious emotional and behavioral problems. Much of her time is spent training graduate students and supervising interns. Susan recently published her second book through the American Psychological Assn.'s Magination Press. The book is intended for use by therapists and protective service workers helping children who have experienced neglect. **Gina Rogers** (gina.rogers72@gmail.com) recently completed a five-year consulting project addressing pediatric healthcare quality and payment models, and continues to perform short-term, smaller consulting work with nonprofits. She recently moved to San Francisco and is enjoying exploring the city and places nearby (including hiking at Yosemite).

Irwin Rosenfeld (oneheadmd@cox.net) retired from the private practice of psychiatry in September 2016, "after practicing for 72 years (averaged 80 hours per week for 36 years)." He spends his spare time playing duplicate bridge, visiting his kids and grandkids in Washington State, and singing in the choir at his local synagogue in Orange County, CA. Irwin regrets that he was unable to attend our 45th Reunion. He was hoping to go, but severe orthopedic problems arose in early March and precluded his attendance. **Richard Krochalis** (rickkrochalis@comcast.net) retired in June 2016 and was recently appointed to the Seattle Design Commission.

He is taking advantage of having free time to volunteer, travel, and audit classes at the U. of Washington.

Mitchell Kase (Lexington, MA; mitchkase@rcn.com) continues to work full time as an MD, now at Harvard Vanguard Atrius Health. He plans to cut back next year to spend more time traveling and writing. The Cornell person who had the greatest impact on Mitch was Prof. **Alvin Bernstein '61**, PhD '69, who, sadly, died prematurely in 2001. **Robert Blye** (rblye@gmail.com) took a three-week tour of South Africa and Lesotho in January 2017, visited England, Scotland, and Wales in April 2017, and now goes birding almost every day. Bob tells us that of everything at Cornell, the Lab of Ornithology had the greatest impact on him. **Michael Halbert** (Valley Stream, NY) travels to horserace tracks and casinos, and hopes to visit "every race track in the world."

Thomas Giordano, ME '73 (Scarsdale, NY; tgcg3@aol.com) continues to provide business valuation services at Anchin, Block & Anchin LLP on a part-time basis in transition to full retirement. **Richard Johnston** is happy in his new role as chief legal counsel to Massachusetts Attorney General Maura Healey, where he advises on legal strategy and oversees three of the four civil bureaus in the office. Rich pursues cases "on behalf of the environment, access to healthcare, consumer protection, and civil rights, in an era when the role of state attorneys general in these spaces is particularly critical." Two of his four grown children live in Boston, one an inner city high school teacher and the other a lawyer at a large international firm. His other grown children live in New York, where one is a social worker and the other is a business consultant.

Gerald Howard (ghoward@randomhouse.com) continues to work busily and happily as an executive editor at Doubleday. He also took a huge leap to the authorial side and is under contract to Penguin Press for a biography of the "great critic, editor, and Lost Generation chronicler" Malcolm Conley. This excites Gerald tremendously, with an undertone of terror, he notes. He and wife Susanne redecorated their servants' cottage in Tuxedo Park from top to bottom, which required patching everything and moving out for two months. Gerald is delighted with the result, but it certainly takes a toll on a 66-year-old body. Ouch. He would love to hear from roommate **Warren Mullison**. Those who had the greatest impact on Gerald at Cornell were professors **Scott Elledge**, PhD '41, **Edgar Rosenberg**, MA '50, and Walter LaFeber—such great teachers and scholars who opened the life of the mind to him. ♦ **Gary Rubin**, glr34@cornell.edu; **Alex Barna**, ab478@cornell.edu.

73 Drumroll, please. Yours truly and spouse Gerry Greenberg are over-the-moon happy to announce the birth of our first grandchild, Claire Elaine, born mid-October to daughter Allison Greenberg (our non-Cornell child) and spouse Adam Licata of South Orange, NJ. Regretfully, the fantasy with which I began my last column six months ago—that the Cincinnati Reds remain in first place in the National League Central—was dashed very quickly. However, as I scribe this column, those damn Yankees are one win away from another World Series, the Reds' Joey Votto had a fabulous season, and I am ready to assume my responsibilities as spoiler-in-chief to my granddaughter!

I gratefully received a succinct response to our plea for class news from **Linda Dubins** (Piedmont, CA; linda.dubins@gmail.com), who sends us all greetings from Northern California, reporting that she is alive and well. I sincerely thank her for replying, which (hint, hint!) too

few of you did. We need your news! **Abby Ershow** (abby.ershow@gmail.com) writes from Columbia, MD, that she is still working, currently at the NIH Office of Dietary Supplements as a senior nutrition scientist, and that many other Cornell alumni work in the ODS as well, including **Johanna Dwyer '60**, **Cindy Davis '86**, **Nancy Potischman, PhD '89**, and **Linda Meyers, PhD '78**. Abby also recently became certified as a Maryland Master Naturalist and expects to be spending increasing amounts of time serving as a docent in central Maryland nature centers.

Paul Klug (pwklug@aol.com) is enjoying life in New Hope, PA, with his wife and older son's family while his son finishes medical school. Paul, who is global head of content operations at Thomson Reuters, based in Times Square, NYC, returns to the Ithaca campus at least twice a year, including participation in an annual Engineering college symposium. He is looking forward to our 2018 Reunion with friends from Fiji. **Sheila Kojm**, MLR '75 (Bedford, MA; boston_kojm@yahoo.com), who roomed right across the hall from me in Mary Donlon our freshman year (48 years ago!), and **Louis Stuhl, PhD '78**, are delighted by the birth of their first grandchild. Elise Rose of Albuquerque was born to **Benjamin Stuhl '05** and Deena Rosenberg at the end of June. I regret to inform you of the death on August 4, 2017 of **Floyd Ira Wittlin** in a bicycling accident. Floyd is survived by his wife, **Paula (Markowitz) '74** (picturebypaula@gmail.com), who kindly wrote to inform us, and daughters Maggie and Natalie. As is said in my tradition, may his memory always be for a blessing.

A couple of classmates traveled in 2017 on study tours with Cornell's Adult University (CAU). **Kenneth Horowitz** went to the Smithsonian in Washington, DC, and **Alice Garr Schiff** traveled to South Africa. Many others took summer classes in July on the Ithaca campus: **Pamela Brown** (architecture), **Martha Burroughs Keagle** (hip hop: music, culture and race), **Debbie Greene Rothman** (cooking), and **Richard Saltz, MBA '74** (photography).

My son, **David Greenberg '05**, has purchased four tickets for our two Cornell alumni selves, his father, and his sister's spouse to attend the Cornell hockey game against Boston U. on Thanksgiving weekend in NYC. We venture east to the bustling Jersey suburbs of NYC for a long holiday weekend with grandbaby Claire and both our children and their spouses, who appear to have migrated permanently to the Promised (Career) Land of Manhattan. I trust I will reunite with several of you at the pre-game cocktail party.

Thanks for all the news. Please submit photos of your gracefully aging selves to <http://www.cornellalumni.com/magazine.com/photogallery>. Send news to: ♦ **Pamela Meyers**, psmeyers73@gmail.com; **Phyllis Haight** Grummon, phg3@cornell.edu; or **David Ross**, dave@dave.ross.com. Online news form, <http://alumni.cornell.edu/class-notes/>.

74 **Betsy Kyger** (kygere@gmail.com) retired last year as a geriatrician and is "reinventing" herself as a literacy tutor in the Buffalo public school system. She enjoys travel and walking her dog with her husband and says she is grateful for the good health of her family members. She would like to hear from classmates! **Leslee Carver** enjoys the freedom that retirement has given her to travel and spend time with her friends and family. She recently visited with **Carol Bradford** and wishes that she could walk with the "same vigor" as she did at Cornell. She tells us that Dr. Rivers and Dr. Devine were particularly influential in her life. **David Wolfthal**, DVM '77, is a veterinarian in Lakeville,

MA. He describes retirement as "barely a blip on the horizon," given that his daughter is starting at the U. of Michigan in the fall.

Hats off to **Eric Roth**, who, along with wife **Laurie (Michael) '75**, has endowed a chair in Jewish history in Arts and Sciences. Eric is a trustee and member of the Dean's Advisory Council in the Arts college. Not surprisingly, he is also loyal to his law school, NYU. Their son, **Jason '05**, has blessed Laurie and Eric with a

Joe Levitt (Washington, DC) is a partner with Hogan Lovells US LLP, and he was named Law 360 MVP in 2016 for effective crisis management for food industry clients. He notes that his wife, **Barbara (Shumaker)**, had the greatest impact on him during his years at Cornell. **Lilly Ramphal** (Arlington, TX) is busy at work as a medical director at Blue Cross Blue Shield of Texas. Her hobbies include oil painting and singing in the choir. Beyond that, she is an adjunct professor in the School

'Retired geriatrician Betsy Kyger is "reinventing" herself as a literacy tutor in the Buffalo public school system.'

HELEN BENDIX '74

2-year-old grandchild, Zoe. Eric reports the influences on his life of professors Richard Polenberg, David Silbey, David Danelski, and Walter LaFeber, his TEP fraternity brothers, and his wife—"not necessarily in that order." In the same spirit of giving back, **Dennis Meermans** is on the board of the Lions Eye Foundation of California-Nevada, which provides free eye surgeries to persons of limited means and no insurance. Dennis enjoys visiting his three grandchildren in Pennsylvania.

Vincent Coggiola has a 5-month-old grandson and takes annual trips to NYC with his friends. He wishes he were a more proficient golfer and stays occupied with his business, Mrs. Butterworth's Auto Tags. **Mark Levy's** mission at the Eppy Group is making sure that "people do not outlive their money." His three children are thriving; one is a recent medical school graduate. Mark reports that he is the proud grandfather of two boys and one girl. **Michael MacNeil** was recently named a 2017 research fellow of the American Society of Animal Science and gives special praise to Coach Jack Warner and Prof. **Doug Hogue, PhD '57**, for his success.

Mimi Ansbro and **Tom Maloney**, MPS '84, tell us that life is good in Ithaca, where Mimi marked her 40th anniversary on the faculty of Tompkins Cortland Community College this year. Tom is a senior Extension associate at the Dyson School, where he specializes in agricultural human resource management. Mimi and Tom are excited about their new townhouse close to campus after living 36 years in Cortland. Their children are also Cornellians: **Georgia '07**, MBA '16, and **Patrick '09**. Both children are in New York City. Georgia is working for an international insurance company, and Patrick is earning an MBA at NYU and working as general manager of a music festival. **Lois Freeman** Bennett and her husband, Charles, took a Cornell trip to Japan in September and had great fun there with other alumni. ♦ **Helen Bendix**, hbendix@verizon.net; **Lucy Babcox** Morris, lucmor1433@gmail.com; **Jim Schoonmaker**, js378@cornell.edu.

75 Shoveling snow vs. hurricanes. Let me think . . . That didn't take long—the former. Not much damage was done to my house by Irma, one of the minority that did not lose power in Orlando/Central Florida. Very lucky, considering how many people were impacted in other parts of Florida, the Keys, and other islands. It was also not as bad as the three that went directly over my house in 2004.

of Public Health at the U. of North Texas. Her family also keeps her busy, with three adult children and two new grandchildren. Congrats! She wishes she had more time to visit Cornell. As she looks back at her Cornell years, she appreciated the mentorship and guidance from Prof. Ari van Tienhoven in CALS, who encouraged her to become a physician. **Robin Michael Koenig** (robin.koenig@comcast.net) recently retired from Walter Reed Hospital, where she worked for 32 years as a child psychologist. She and **Scott '73**, PhD '79, are grandparents to 3-1/2-year-old Maya and newborn Eli.

Sandra Sills-Wyche (ssw2u@aol.com) contemplates retiring in about two years. She'd enjoy hearing from **Christine Moore Morrison** and **Magdalena Ramirez**. "Prof. Turner," she writes, "had a huge impact on me." Class president **Louise Vacca Dawe** (Ldawe75@gmail.com) and husband **Michael '76** are now both retired. Louise is active every day, walking, golfing, skating, or doing yoga. Last summer, "inspired by a figure skating event, my passion," she wrote a book, *Patterns on Black Ice: The Art & Sport of Figure Skating*. You can find it on amazon.com. Louise loves being a part of her grandsons' lives, age 4 and 5. "Their innocence is uplifting, and sharing their new experiences is such a joy." **Noel Kemm** (Salem, NJ; Noel.Kemm2@verizon.net) volunteers at the Salem County Humane Society, is on the library committee of the Salem County Historical Society, and plays trumpet with the Salem American Legion Band. Son **Matt '03**, Captain US Army MD, is finishing at Walter Reed Hospital and being reassigned to the Army hospital in San Antonio. Noel would like to hear from **Jan Miller**.

John Niznik (King George, VA; Kg.vet@hotmail.com) has owned the King George Veterinary Clinic since 1994. He's also a member of the King George Chamber of Commerce, and for four years has been president of the Virginia Academy of Small Animal Medicine (providing lectures and conferences throughout the year). He and wife Citlal's oldest, John Jr., was graduating from Rappahannock Community College when he wrote; middle child Patricia has her BS from Concord U. in West Virginia; and the youngest, Caitlin, is a senior at the U. of Mary Washington in Fredericksburg, VA. John wishes he could be traveling more, particularly to Spain, although he visited Hawaii two years ago and Cancun last year. He would like to hear from **Aaron Alexander**, **Dan Carey '76**, and **Dave Green '76**. Who, at Cornell, had the greatest impact on him? "Professors at the Ag school."

Susan Lustick, MS '77 (Ithaca, NY; slustick@gmail.com) is still working in real estate and is fortunate to have three grandchildren living in the same city. Susan has a weekly radio show, House Call with Susan Lustick, AM 870/FM 95.4. **Debra Peltz** Brook and **Marjorie Brooks**, Susan would like to hear from you. Greatest impact? Prof. David Levitsky, with whom Susan did her honors research and master's. **Robert Williams** (East Aurora, NY; rww2@roadrunner.com), my Signa Nu roommate for two years, and his wife, Mary, have two married daughters and three grandchildren. Robert is a physician and surgeon with Buffalo Medical Group and is chief of otolaryngology/head and neck surgery at Mercy Hospital in Buffalo, hoping to retire in two years. In his spare (?) time, Robert plays music in an Irish/Celtic

in Riverdale, NY, and Lockport, NY, respectively. After Cornell, Joe joined the Peace Corps and built rural roads in Sierra Leone. Private sector jobs then followed in Colorado and Vermont, and later city engineer jobs in Amsterdam, NY, and Saratoga Springs, NY. He wrapped up his career with 32 years at the NYSDOT. He and Pat are hoping to visit and/or host many of his classmates (including **Abdullah Paksoy**, ME '77) from his home base in Albany, NY.

Gale Climenson Walters is still utilizing her Food Science knowledge in her work. She has two grandchildren, has begun a Pilates practice, and is trying to get back to running, but has had some setbacks and had to stop. She would like to travel to see family scattered across the US; however, she has two old dogs that

Gmeiner '74 and wife Faye, a Tufts alumna. My mother, Frances Diamant, attended so many Cornell Reunions with my dad, **Leo Diamant '44**, that she is an honorary Cornellian. If our names are confusing, it's that my maiden name was Diamant and so is my married name. **Suzy Schwartz** Quiles called me Lisa Diamant Diamant for some time!

Please keep your news coming! We have only missed one deadline in all these years due to lack of news. ❖ **Lisa Diamant**, Ljdiamant@verizon.net; **Karen Krinsky** Sussman, Krinsk54@gmail.com; **Pat Relf** Hanavan, patrelf1@gmail.com.

77 Greetings from Cambridge, MA. I'm delighted to join our great team of class officers as a class correspondent and am excited to be in touch with my classmates once again! Thanks to **Howie Eisen** for the warm welcome as I take on this new role. I look forward to partnering with Howie to share the latest news of our classmates' comings and goings.

Before I begin my new duties, I'd like to tell you some of what I've been doing by way of introduction. I've worked in the Boston area for all of my career, in various public sector positions focused on city and environmental planning and management. I hope to retire in the not-too-distant future. To prepare for all the free time I will have, I've become active in local community affairs, serving on the City of Cambridge Planning Board since 2014. I also serve on the board of the Shirley-Eustis House Assn., a nonprofit responsible for the preservation and programming of this historic royal governor's mansion located in Roxbury, MA. The Shirley-Eustis House was built between 1747 and 1751 and is one of four remaining colonial governor's mansions in the US. I also enjoy unwinding at my small summer cottage in beautiful Wells, ME, and plan to spend most of my summers there in the future. My passion is travel and I've been fortunate to explore many parts of the world throughout the years. This past March, I had the pleasure of traveling to Africa with the Cornell Alumni Assn. Travel Program. This was a great experience, one I highly recommend, and a fun way to meet Cornell alums of all ages.

Several other classmates traveled this year with Cornell's Adult University (CAU) off-campus programs. **Judith Gross** participated in the NYC Spring Theater Weekend, led by Prof. **Glenn Altschuler, PhD '76**, while **Robert** and **Ellen Epps Ludwig** attended the Spring Migration program in Cape May, NJ, led by Profs. Eliot Miller and Sarah Wagner. **Diana Wainrib** traveled farther afield, joining the CAU trip to Cuba with Prof. Maria Cristina Garcia.

Michael Nolan and wife Alexandra live in Montclair, NJ. He just celebrated his 25th anniversary at JP Morgan, where he helps young people like us ensure that they have enough savings to last through retirement. Their oldest son, **Brian '09**, joined "Team Nolan" in October 2016. Peter (son #2) graduated from Harvard Business School in May 2017 and is working for Vanguard; and Stephen (son #3) is studying to be a physician assistant. Michael looks forward to being a grandparent. He would love to hear from Andrew Dickson White (don't get your hopes up). **David Call '54**, PhD '60, "the most amazing dean (of CALS) one could imagine," had the greatest impact on Michael during his time at Cornell.

Jeff Erickson, MCE '80 (Waterville, ME) notes with some bemusement that his old Cornell room was turned into a women's bathroom. He is still working, but thinking of retirement in the next year or two. He wishes he did not have to shovel snow, but this is the price of living

'Greacian Goeke is an artistic director of a dance ensemble of elder women called Impromptu No Tutu.'

LISA DIAMANT '76

band. (Note: If those of you reading this have never seen *Lord of the Dance*, Irish music and dance, you are really missing something. It's incredible.) Robert also plays Civil War era music. He was inducted into the North American Irish Music Hall of Fame in 2005. **Jane Rabbino** Miller (janemiller460@gmail.com) and husband Carl have an active lifestyle in The Villages, FL: pickle ball, golf, swimming, book club, dinner clubs, biking, and walking. They have two grandchildren.

Steve Kelleher (Pickering, ON; skelleher94@gmail.com) retired in April 2014 from Hyundai Auto Canada after 28 years, the last 12 of which were as its president and CEO. Since then, Steve has successfully driven down his golf handicap and adopted curling as his winter sport. **Ann Welge** Schleppe (Sun City, AZ; katjunky@me.com) and spouse Craig are living in a retirement community. She writes, "Going to work while neighbors go out to golf or bike has been my biggest challenge!" Ann is working for benefits, experimenting with the retirement lifestyle, and keeping in good health so she can enjoy retirement. They bought a Titan Pro 4X XD (a diesel four-wheel drive for off-roading). "Next step is the fifth-wheel, so we can take our seasonal home on wheels with us as we wander the country." Ann would like to hear from old friends **Barry Marcus '74** and **Louise Holzer** Sullivan. Greatest impact? "Faculty advisor Lloyd Street, with his 'unconventional,' more eclectic philosophy, approved my increased hours in field instruction, enabling me to grow as a future social worker. We 'bucked the system' together." ❖ **Mitch Frank**, mifgator@gmail.com; **Joan Pease**, japease1032@aol.com; **Deb Gellman**, dsgellman@hotmail.com; **Karen DeMarco** Boroff, Karen.boroff@shu.edu.

76 Thank you to **Joe Doherty** (doherty1@nycap.rr.com) for his patience in getting his news into this column. Joe writes that he retired in late 2016. His wife, Pat (a BU alumna, but please don't hold that against her), retired a few months earlier from her job as editor of the NYS Bar Assn. News. Their daughters, Meaghan and Caitlin, live happily with "significant others"

don't do well in boarding, so travel is limited now. **Alice Mascette** is busy with crew at 5:30 a.m., chorus at 7:30 p.m., and golf in between. She recently reconnected, after about 20 years, with final semester roommates **Lisa Marshall** and **Gigi Altmiller** McIntosh. Alice and Gigi had lunch together near Gigi's home in Pennsylvania. Alice also attended Cornell's SDT Alpha Chapter Centennial in March and was happy to see lots of sisters from her class as well as "the pledges," now 60 years old.

Greacian Goeke, who is really Class of '75 but graduated with us in '76, is a working artist with no plans to retire. She is an artistic director of a dance ensemble of elder women called Impromptu No Tutu. They are models of creative aging! Their main focus is introducing younger generations to the life skill of improvisation through movement, dance, and poetry. Greacian's spouse, **John Cowan '73**, MFA '80, is continuing to develop his repertoire as a finger-picking blues guitarist and builder of one-string diddley bow instruments. He has a YouTube channel (waxwingjohn), where he demonstrates these. Greacian would like to be making more art, doing more dancing, and taking their art around the world. She would like more hours in the day!

In retirement, **Elaine Aderhold**, MS '81, enjoys civic activities, golf, gardening, Packers games, and mahjong. **Bill Dalrymple**, MS '81, is still busy working to create a beautiful town center in Fitchburg, WI. They are first-time grandparents to a beautiful baby girl. Last year they made family visits to Ireland, Scotland, and Greece. After teaching science for 36 years, **Vincent Nardoza** retired. He now makes one-of-a-kind woodcraft gifts, which you can learn more about at: www.woodcraftsbyvinny.com. **Karen Pauline Lucas** says that while at Cornell, **Bob Gardner '73** convinced her to give the Engineering college a try. **Derwood Trimbell** is a corporate quality process manager for Empire Packing Co.

On a personal note—a benefit of being a class correspondent—my daughter, Julia, was married in Boston over Columbus Day weekend. My husband, **Morris Diamant '74**, and I were joined by fellow Cornellians **Ira '79** and **Chari Smith Diamant '81**, and **John**

in Maine. He would like to see **Dan Merrill '83**, MEE '84. **Karen Juli** (Auburn, NY) would like to hear from fellow Cornellian **Michele Burlew**. **Kathleen Lamb** Wheatland writes from Melbourne, Australia, where she has worked as a clinical dietician in orthopedic rehabilitation and palliative care. For the last 15 years, Kathleen has been employed by Peninsula Health. She and her husband, Lance, have been married for 36 years and have four adult sons and three grandchildren. They live in Boronia, a suburb of Melbourne named after a native wildflower. Kathleen was not able to attend our 40th in Ithaca, but had a reunion with her Cornell roommate **Carrie Cornish** in July 2016. She would enjoy hearing from **Susan Davidson** Smith, **Debbie Pope** McCasland, **Mary Aulet**, and **Rosa Tu Tang**.

In 2015, **Vernon Anthony** began a new business in Piscataway, NJ. VA IP Consulting provides business and technical services to individual investors, research institutions, and technology companies that seek maximum value from their intellectual capital. You can see more about his firm at vernonanthony.com. **Brian Dunn**, MBA '81, is retired and back in Ithaca, teaching a graduate level course at the ILR school. Prior to that, Brian was in Vatican City, where he advised on the creation of a human resources function. He also serves on a few boards and does some consulting. He writes that retirement is busy, but fun. Brian's family is also quite busy. Daughter Colleen is in her second year of law school at Fordham, and son Patrick was married in July 2017.

James Allchin, ME '78 (Penfield, NY) recently retired after a 37-year career at Xerox Corp. He keeps busy with skiing, biking, and house projects. **Cheryl Spielman** (Delray Beach, FL) also retired, after 38 years with Ernst & Young. In her last position, Cheryl ran the financial services human capital business for the firm. She has recently been appointed to the board of First Republic Bank. Cheryl and her husband, Myron Bari, share six children and eight grandchildren. That's it for now. Please keep all of your news and views coming in via the online news form (<http://www.alumni.cornell.edu/class-notes/>) or to us: ♦ **Mary Flynn**, maryflynn1@me.com; ♦ **Howie Eisen**, heisen@drexelmed.edu.

78 Happy New Year, fellow '78ers! I'm looking forward to seeing lots of you at our 40th Reunion in June. This column should whet your appetite for catching up with long-lost classmates and visiting locations around campus and Ithaca in June.

Leah Minemier MacLeod (Concord, CA; Immacleod@gmail.com) has a relatively empty nest, as husband **Don '77**, BS '81, is working six hours south of her at UCLA and her children are hither and yon. Her daughter, **Hannah '12**, works at Telltale Games and has worked on Minecraft Story Mode and the YouTube series Vanity. One son works for Ricoh, and the other is attending Moorpark College for video game design. In between traveling to visit her family, she's attended a family reunion in Dansville, NY, and a teacher reunion in Oswego. Leah sends a shout-out to her SDT sisters as well as the Acacia guys from the classes of 1975-80. If she had a day (or maybe four) in Ithaca, she says she would tour the Straight, visit Stewart Park, and meet up with friends in Dryden and Lansing.

Laura Howes (Knoxville, TN; lhowes@utk.edu) has been a professor of medieval English at the U. of Tennessee for 27 years. She helped start the Marco Inst. for Medieval and Renaissance Studies. On her last visit to Ithaca, she bought three used books at the Bookery in Dewitt Mall that had belonged to two of her favorite professors, M.H. Abrams and Winthrop Wetherbee.

Laura elaborates: "Abrams made the sophomore me want to be an English major; Wetherbee awakened my lifelong love of Chaucer." **Lori Rothman** (Oak Park, IL; lorirothmanconsulting@gmail.com) has happily made the switch from working for "the man" to working for herself. She provides product development direction to food companies, based on the sensory properties of the products to be delivered. She also audits sensory evaluation functions of food companies and teaches at Dominican U. Her older son is a transportation planner in Fort Lauderdale, FL; her younger son is a consultant in Richmond, VA. Lori would spend her day in Ithaca visiting the gorges. She went to Peru with Cornell's Adult University (CAU) last year.

Jim Ball (Meridale, NY) is staying busy keeping his mother out of the nursing home and visiting twin grandchildren in Boulder, CO. He built a pool in 2016 and didn't spend much time in it this past summer because it wouldn't stop raining. Jim has a mystery to solve. He'd like to get in touch with a classmate named Diana "who drove a Rambler and drank me under the table at Ruloff's, the Palms, etc., the night before graduation." The other clue is that Diana's parents had a house on Lake George. Can anyone solve this mystery? If you happen to be the Diana, get in touch! Several classmates attended Ithaca-based CAU classes during the summer of 2017. **Toby Brown** Gooley toured the gorges, and **Betty Stanulis Thacker** took a photography class while husband **George** learned how to compose a personal essay. Farther afield, **Leslee Moore** took the CAU tour of Russia.

Now for my day in Ithaca: Breakfast at Collegetown Bagels, preferably including a bialy. Running around campus to see what's new and if there's anyone around I remember from undergrad or grad school. Lunch at the Vietnam Restaurant in Collegetown (on Dryden Road, across from the late, aforementioned Palms and next to what used to be Johnny's). Walking down Libe Slope and over the Suspension Bridge. Listening to the 6 p.m. chimes concert. Dinner's open—any ideas? That's all the news for now. Please note my co-correspondent has a new e-mail address. See you in June! ♦ **Cindy Fuller**, cindy@cindyfuller.com; ♦ **Ilene Shub** Lefland, ilene.lefland@gmail.com.

79 Welcome to 2018, which means our 40th Reunion is only 18 months away! It's not too early to start reaching out to Cornell friends and setting aside time to be in Ithaca June 6-9, 2019.

We heard that **Susan Heller**, a leading intellectual property attorney both domestically and internationally, has been selected once again by the editorial team at the *Daily Journal* for inclusion on its "Top Intellectual Property Lawyers" list. Susan is a partner at Greenberg Traurig in Los Angeles, where she serves as chair of the firm's global trademark and brand management group and co-chair of the firm's global women's initiative. **George Schultze**, a classmate in the ILR school, went on to earn a PhD from the U. of Southern California in philosophy, theology, and ethics, and became a Catholic priest. Fr. Schultze has held various positions, culminating on Monday, August 21, 2017, as the St. Patrick's Seminary and University in Menlo Park, CA, celebrated his installation as the institution's 17th president-rector. A Jesuit, Fr. Schultze currently serves on the board of Catholic Charities of the East Bay and is an advisor to Catholics for the Common Good.

This fall, our former class president **Jeff Berg**, ME '80, MBA '81, was honored with the presentation of the

Frank H.T. Rhodes Exemplary Alumni Service Award. This award recognizes alumni who have given long-term volunteer service to Cornell. Jeff joins other classmates to receive this award, including **Ted Teng**, **Brad** and **Mary Maxon Grainger**, MPS '87, and **Ginger So**. In November 2017, about 60 classmates gathered in NYC and took a tour of the new Cornell Tech campus on Roosevelt Island, followed by a dinner reception where attendees raised their glasses and celebrated the start of a new decade—our 60s!

Several classmates responded to our news form asking questions about their current activities and who they first met upon arriving freshman year. **Karen Jewett-Bennett** lives in Ithaca and was recently appointed to a full-time position with Cornell Dining. She invites classmates to stop by and see her at Oakenshields in Willard Straight Hall. Karen and her husband, Hal, recently celebrated their fifth anniversary, and in their spare time they enjoy fishing on Cayuga Lake. When Karen thinks back to her arrival on campus, she remembers meeting her roommate, **Lisa Barash**, followed shortly by **Sue Holzberg**, **Scott Thompson**, and **Jimmy Schoonover**.

James Tenser and his wife, Valerie Propst, live in Tucson, AZ, where they enjoy hiking in the mountains and spending time with their four adult children. James founded a company named VStoreNews in 1997, which was e-letter focused on the then-emerging online retailing sector. That company, now known as VSN Media LLC, has become a strategic content marketing advisory, focused on retail technology. James writes, "While the deliverables have evolved to fit the mediascape, VSN remains rooted in industry analysis, market strategy, and storytelling. After two decades of entrepreneurship, retirement remains years away." Writing and photography are James's creative outlets. The first person he met at Cornell was his roommate, **Jeff Moskow**. Among the things James would do on a return trip to Ithaca: "Hike Treman State Park in the morning; wander all over campus in the afternoon; order cashew chili at Moosewood and sulk if it's not on the menu; kiss my wife on the foot-bridge at midnight." We say: Come to Reunion June 6-9, 2019 and do it all!

Be sure to send us your news! We want to hear from you! ♦ **Cynthia Ahlgren** Shea, cynthia.shea@sothebys.com; ♦ **Kathy Zappia** Gould, kathy.gould57@gmail.com; ♦ **Linda Moses**, lindakmoses@gmail.com. Online news form, <http://alumni.cornell.edu/class-notes/>.

80 People ask me—correspondent **Dik Saalfeld**—about my financial planning, vis-à-vis my early retirement. After all, vacations and generally goofing around comprise the bulk of my life these days. The key, of course, is not to have children or former spouses. Staying away from heroin, Italian cars, and gambling helps, too. Also, one must cast a critical eye upon discretionary spending: do I really need a vacuum-insulated titanium 64-ounce beer growler covered in hand-stitched elk skin? Of course! But at some point, you have to draw the line; otherwise, large humorless men will pay you uninvited visits. Or so I hear. Incidentally, "vacation" can be used, in a broad sense, to mean "exile."

Jill Lonati Curtis has moved to Singapore, where her husband is on assignment for Chevron. They will travel extensively in that part of the world, and hope to have many visitors. **Lucy Avellino McQueeney** and husband **Mike** moved back to the Northeast after spending many years in Houston and Atlanta. She writes, "All three of our children graduated from the ILR school: **Courtney '12**, **Allison '13**, and **Michael '17**. Courtney

married Kyle Shute in 2016. Alumni from many classes attended the wedding. Allison is attending Cornell Law School, and Michael is attending UVA Law School. We love being back in the Northeast and have had multiple opportunities to visit Cornell over the past few years."

Scott Picon writes that it's been two years since he and his partners and investors opened Diamante Eco Adventure Park in the Guanacaste province of Costa Rica. Guests can partake of a number of outdoor and adventurous activities. The website is <https://diamanteeco.adventurepark.com/>, where you will learn that "Diamante's Animal Sanctuary is Guanacaste's largest, and home to the largest variety of species in one location. The animals are rescued by MINAE, the Costa Rican Ministry of Wildlife, include sloths, monkeys, jaguars, toucans, snakes, and more. The habitats are designed to provide a natural setting for the animals, while allowing guests to learn and enjoy a unique, safe experience."

Soprano **Nanette Cooper** McGuinness's third CD, "Surviving: Women's Words," with the chamber music group Ensemble for These Times, won a Silver Medal in the 2016 Global Music Awards, and two of the songs on it were named finalists in the Global Peace Song Awards. She's recording a new album with a working title of "The Hungarians: Miklos Rozsa & Others." Nanette also translates fiction, non-fiction, and graphic novels for children and adults. **Mark Steckel**, an ophthalmologist with a specialty in pediatric ophthalmology, saved himself from a puck in the eye at the NCAA hockey tournament—he caught it when it was deflected into the stands. Mark gave an unusual answer on his news form. Instead of listing professors who had the greatest impact on him during his Cornell days, he told of the financial aid officer who counseled him and his dad on how to afford Cornell tuition. Mark's story hits home with this correspondent, who, as a financially emancipated 17 year old, became intimate with the financial aid office in Day Hall. I join Mark in thanking the tireless workers there for their help.

Karen Williamson is now working for Lehigh U. She is in the Campus Planning office, where she is involved in exterior improvements as well as the development of the university's global information systems database. **Sukwah Lai** Lin writes that, although she is a nutrition consultant by trade, she is pursuing a second undergraduate degree—this time in music. She says she wants to "bring my songs out to the world!" She would like to hear from her former suite-mate **Migdalia Flores** Silvestros. Some baseball purists were upset when classmate and Major League Baseball commissioner **Rob Manfred**, in a bid to speed up the game, instituted the no-pitch intentional walk rule before the 2017 season, but most fans, by my reckoning, don't miss watching the four pitches. (Johnny Bench thinks the rule is way overdue, but Rollie Fingers is weeping softly.) The real thing slowing down ballgames, though, is rampaging capitalism, but I'm just going to leave it at that.

Remember to check out the Class of '80 Facebook page! Also, our 40th Reunion is only a couple of years away, which used to be forever, but now is within the margin of error when you're trying to remember the last time you had the oil changed in the Studebaker. ♦ **Dik Saalfeld**, rfs25@cornell.edu; **Dana Jerrard**, dej24@cornell.edu; **Leona Barsky**, LLB39@cornell.edu.

81 **Anita Meiklejohn**, a principal in the Boston office of Fish & Richardson, was recently in the news as a recipient of the 2017 "Women Worth Watching in STEM" award by *Profiles in Diversity Journal*,

as well as being named a 2017 "Top Woman of Law" by *Massachusetts Lawyers Weekly*. Anita specializes as a patent advisor to the pharmaceutical and biotech industry, with clients ranging from startups to academic institutions and established biopharma companies. She is a member of the management committee of Fish, which is a leading intellectual property law firm. After majoring in chemistry at Cornell, she received her PhD in biochemistry from UCLA in 1987 and her JD from Boston College Law School in 1995. Congratulations!

Hailing from Cambridge, England, **Matthew Kramer** (mhk11@cam.ac.uk) is professor of legal and political philosophy at U. of Cambridge and a fellow of Churchill College, Cambridge. He was elected as a fellow of the British Academy in 2014 and has authored 16 books and co-edited four additional titles. Recent publications include *Liberalism with Excellence* and *Torture and Moral Integrity*. He devotes almost all his time to his philosophical work, but also runs daily and enjoys Shakespearean drama and classical music. **Jim Kent** and Lisa Weber (a 1991 graduate of Marshall U.) were married on September 9 in a garden wedding in Winchester, VA. Among those attending was Jim's son, **John '13**, who is a third-generation Cornellian; Jim's late father graduated as an engineer in 1948. Jim reports a gorgeous honeymoon over eight days on the western shore of Maui. "Very relaxing. We were so bummed to come home."

Eckert Seamans Cherin & Mellott LLC announced that **Ray Middleman** has joined the firm as a member in its Pittsburgh office. Ray earned his JD from the Duquesne U. School of Law in 1984 and has had an active, diverse litigation practice, with cases ranging from product liability to construction claims and shareholder rights disputes. **Joan Kleinman** (kleinwit@verizon.net) writes from Bethesda, MD, that she has recently become state director for US Senator Chris Van Hollen of Maryland. **Jeanette Brizel** reported that she has joined the College Board as VP, human resources.

David Corbett (corbettdb@gmail.com) is a registered social worker in Kitchener, ON, where he is in private practice as a pastoral counselor and therapist. His oldest daughter, Beth, just entered the Cornell/Queen's U. Dual Executive MBA Program this summer. Daughter Rebekah just finished her BA at U. of Waterloo (with distinction and honors) and is taking a year to intern before starting her bachelor's in social work at U. of Waterloo. She aims to follow in her dad's footsteps and eventually gain a master's in clinical social work. His third daughter, Christina, entered the DVM program at Ontario Veterinary College in September 2017. Son Blair is presently working as an assistant chef in Waterloo and is planning for a career in graphic design. Practicing law in northern New Jersey, **Anthony Boyadjis**, JD '84 (aboyadjis@gmail.com) continues an annual pilgrimage to the Hill each January to compete in the Hartshorne Mile indoor track meet and enjoy hanging out with classmate **Tim Riccardi**. Anthony and his wife, Lauren, live in Maplewood, NJ. Many thanks for your updates. Please keep sending us news! ♦ **Steven Barre**, sbarre@aol.com; **Betsy Silverfine**, bsilverfine@comcast.net; and **Tanis MacKay**-Bell, TanisMBell@gmail.com.

82 Happy New Year! Doesn't seem possible, as I write this copy in October. We were honored to welcome President Martha Pollack to Boston on her alumni tour in September. She was, as we had heard, approachable, honest, and already fully conversant in our beloved Cornell. The program was scripted as a Q&A

session, and after meeting "Martha" and hearing her speak about the state of the university, in Ithaca and NYC, we felt Cornell had named another truly great leader! Please watch for the president's tour traveling to a city near you!

Beth Berman Zipper wrote from Boca Raton, FL, where she is retired and volunteering nutrition services in the community. Her youngest, daughter **Jamie '21**, is a freshman in the Arts college and joins her brothers **Harrison '10** and **Brandon '13** as legacies. Beth loves spending time with her granddaughter and grown children and feels lucky to have her parents and in-laws around. She and husband Jeffrey, who retired from medicine, say, "Boating is our future!" Beth adds that her first friend at Cornell was **Debbie Weisbard** Tiedrich, who found her about six years ago for a reunion in the Poconos. She still sees **Vickie Gladstone** Dubin, whose daughter, **Amanda '18**, is a senior in HumEc. If Beth had a day in Ithaca, she would visit the vineyards, do the Cayuga Wine Trail, and enjoy visiting the gorges and hiking.

Miriam Akabas changed from teaching computer science to being an accountant about six years ago. She is proud to be a grand-aunt to a grandniece and two grandnephews, all born to Cornell men in 2017! Her nephews are **Shai Akabas '09**, **Samuel Akabas '07**, and **Tal Akabas '11**, ME '12. If Miriam had a day in Ithaca, she would visit her daughter and nephew, visit the museum and omithology lab, and take a walk on campus.

Classmates who returned to campus last July for Cornell's Adult University were **Richard Garvin**, who participated in Freedom and Justice in the Western Tradition, led by Prof. Isaac Kramnick, and **Ed Swaya**, who joined the Advanced Digital Photography workshop given by Jennifer Gioffre and David Todd. For those of you interested, CAU runs on-campus courses and off-campus study tours to destinations around the world. More information can be found at: www.cau.cornell.edu. "These non-credit courses, designed and led by some of Cornell's most gifted faculty, allow alums to enjoy the educational life of our exceptional university in the company of other bright, curious, and warmly engaged adult learners." Please write with your news! ♦ **Nina Kondo**, nmk22@cornell.edu; **Mark Fernau**, mef29@cornell.edu; **Doug Skalka**, dskalka@npmlaw.com.

83 Hello, Class of '83! While this column is published in the cold of winter, I'm writing it midst the unusually warm fall weather of October. So when you're reading this, it'll be only about six months until our 35th Reunion in June—hope to see you all there!

I'm happy to report we have quite a bit of news this month, so I'll get right to it. Several of our classmates have new Cornellians in their lives. **Seth Harris** writes, "I returned to campus in mid-August with my family for the most important of all reasons: helping my oldest son, **Jonathan '21**, to launch his new endeavor as a Cornell freshman. Pride, excitement, sadness, and nostalgia mixed together over that weekend, along with the pleasant surprise of learning that old-time friends **Tom Allon '84**, **Fran Ratner '84**, and **Steve Biener '84** also can boast of children in Cornell's newest freshman class. This is going to be a great class. And now we have plenty of excuses to return to the Hill. See you at Parents' Weekend!"

J. Michael Jenner '82 let us know that his son **William Lindsay Jenner '21**, grandson of **John '57**, MBA '59, and **Jessica Reynolds Jenner '59**, would be attending Cornell Engineering as a freshman in 2017. He says

he gets the most satisfaction from “two great boys, both studying engineering, at Cal Poly and Cornell. Fun with my wife of 28 years as empty nesters!” **Cynthia Crier**, MArch '85 (cbc581@aol.com) wrote in with great news: “In addition to my fine art painting (www.cynthiacrier.com), I am now designing clothing and accessories for VIDA (https://shopvida.com/collections/cynthia-b-crier).”

Laurence Goodman has been selected for inclusion in the 2018 edition of the *Best Lawyers in America*, one of the legal profession's oldest and most respected peer-review publications. He was recognized for his work in the practice areas of employment law-individuals, labor law-union, labor and employment litigation, and employee benefits (ERISA) law. **Lynn Leopold** (lynnm.leopold@gmail.com) writes, “I have been designated as the NYC Law Dept.'s law enforcement coordinator for the Family Court Division, and I participate in the NYPD's anti-gang initiatives and other activities regarding juvenile crime. I was also named the chair of the community service committee for the NYC Law Dept. I see numerous '83 Alpha Phis including **Linda Park**, **Liz Merrill**, **Glennis Barr**, and **Betsy Title Silverman**.”

Transitions play an important role for many of us at this stage in our life. **Ruth Fenton** Vest reports that she is “revamping, reinventing, and relocating!” She is excited about new beginnings and shared that she's selling two homes in Richmond, VA, one a four-bedroom Dutch colonial, the other a five-bedroom historic mansion. For more information, check out: <http://cvrmls.mlsmatrix.com/Matrix/Public/Portal.aspx?ID=1648652481#1>. **Brad and Dina Wolfman Baker** (dinab1@verizon.net) wrote, “On September 9, we celebrated the marriage of our son, Isaac, to Paige. Cornellians celebrating with us included our daughter (sister of the groom and a bridesmaid), **Audrey Baker '09**, MPA '15 (now on staff of the Cornell MPH) as well as classmates **Carin Lewis** Evans and **Ann Trautman** Spindler.” **Dan Parker** (dan.parker@eaglecreekre.com) is the vice president, business development for Eagle Creek Renewable Energy in Morristown, NJ. He has two wonderful granddaughters, Adelene and Everly, and remembers fondly Prof. Emer. **Harlan Brumsted, PhD '54**, as having a great impact during his years at Cornell.

Save the date for Reunion 2018! Reunion is fast approaching, so mark the weekend of June 7-10, 2018 for a trip back home to Cornell. **Susan Wasserman** Guerin, **Andy Sosa**, and the class officers have plenty of fun and excitement lined up. In addition to a full slate of university events, the Class of '83 will host a panel discussion featuring four distinguished classmates and moderated by **Gretchen Ritter**, the Harold Tanner Dean of Arts and Sciences. This year we'll be housed in the luxurious (and air-conditioned) Townhouses on North Campus. While not quite the Residence Inn, they do feature double rooms, kitchenettes, spacious living rooms, and semi-private bathrooms. Start packing your tennis gear, golf clubs, and rain gear for a wonderful weekend catching up with old friends (we are all over 50 now) and exploring all the new spaces on campus.

Please visit our Facebook page and post pictures from your time on the Hill (www.facebook.com/CornellClassOf1983/) and our Class of 1983 Cornell web page (<https://alumni.cornell.edu/come-back/reunion/classes-groups/class-of-1983/>); and join our group on LinkedIn (<https://www.linkedin.com/groups/4749373>). To keep the great momentum going in preparation for Reunion, we'd love to receive your updates. Please e-mail your news to my co-correspondent or me, or use the online news form at: <http://www.alumni.cornell.edu/>

class-notes/. ❖ **Barb Warner** Deane, barbdeane@barbdeane.com; **Jon Felice**, jbfelice@jbfelice.com.

84 As I write this column, the leaves are changing color and Homecoming weekend is coming up. I hope to see many classmates next weekend. Though news from that event is yet to be made, our classmates had much to share.

Elizabeth Scott is working for the New Jersey Center for Teaching and Learning (NJCTL), a nonprofit educational consulting firm that offers math and science curricula and teacher training in the US and African countries. “I'm responding to the form for the first time because it recently occurred to me that this job brings me full circle from double majoring in Biology and Society (now called Global Health) and Genetics and Development at Cornell, to training science teachers in developing nations 33 years later. I never would have predicted this outcome, and I had no idea why I chose those majors when I was there, other than that I thought they were interesting topics.” Between college and her work with NJCTL, she raised three children with husband **Larry Bradley, JD '85**, got a PhD in immunology, taught science, and volunteered for Planned Parenthood and other progressive organizations. Our online form asked who was the first person we met at Cornell. Elizabeth's response was **Ann Coulter**. It's a great story best told in person!

My fellow townie **Diane Matyas**, MFA '89, is still based in Staten Island as the VP of exhibitions and programs at the Staten Island Museum “in a LEED Gold geothermal (triple) landmarked building at the Snug Harbor Cultural Center.” The center's exhibitions include art, science, and history themes. Both of Diane's children are theatre bound, with her son studying nonprofit management and acting, and her daughter studying theatre design. Diane and a partner were finalists in the Future Culture public art grant competition. “Flyway Home was our unique project that introduced gigantic birds, nest-like structures, and a community sunflower sowing installation in the changing northern shoreline of Staten Island.” Diane and her daughter, Winsome, spent some time in the Finger Lakes visiting Ithaca and Seneca Falls, learning about the early suffrage movement in NYS, and swimming in Enfield.

Earl and Kathryn **Kim** are back East in Stamford, CT. Earl writes, “After four wonderful years in Hawaii working at Kamehameha Schools, Kapalama Campus, it was with sweet sadness that I returned back East.” He is currently the superintendent of schools in Stamford. Earl was able to reconnect with Big Red alumni and wrestling coaches at the Easterns and is looking forward to the NCAAs in Cleveland this coming spring.

He reports, “Our daughter, Lauren, is a full-fledged Lieutenant of Marines, doing her follow-on training in glorious Twentynine Palms, CA.” Their son, David, is at the Naval Academy. Earl loves writing, “with the hope that someday I have something important to share.” I think he shares the dream of many Cornell alums, writing: “I'd love to be a student for a day, listen to great lectures, read great books in the Willard Straight Reading Room, go to wrestling practice (if my bones could handle it), and engage in intense conversations over dinner and coffee.” Okay, maybe we share the same dream . . . except for the wrestling part.

Terri Port has a new job at Pure Storage as a global account director, which has her traveling a lot. “When people ask where I live, I joke that I pick up my laundry and dry-cleaning in New Hampshire,” she writes. The silver lining to all the travel is the ability to work in visits with Cornell friends like **John Gallagher**, MBA '89, in Santa Clara, CA, where John is the VP of marketing for Viakoo Inc. She saw **Kim Lawson** Murphy '85 while on a trip to Nashville. Kim gave her a fantastic tour of the city, which included the Kappa Alpha Theta house at Vanderbilt. She caught up with **Joan Guilfoyle** and her family while in the D.C. area. Terri's son, Harry (with whom I have a throwing-rolls-at-dinner kind of relationship), is a sophomore at Merrimack College. Terri longs for the days of “breakfast at Colletown Bagels, a walk around campus, a trip to the Dairy Bar, more walking around campus, and then dinner at Moosewood.” **Jeff and Amy Leach Wearden** welcomed their first grandchild, Ishmael Jeffrey, last August (Cornell Class of 2038?).

We had several classmates enrolled in Cornell's Adult University, both on and off campus. **James Mann** took the Wines Course, while **Micah Greenstein** took Positive Psychology and Personal Well-being. **Susan Guest** Henninger attended Cuba: Havana and Washington—Renewed Relations. Take a look at the CAU offerings—we don't have to simply dream about a day back in Ithaca; we can spend a week back on campus as students. Best of all, no midterms or finals! Send us your news! ❖ **Catherine “Kitty” Cantwell**, catherinejcantwell@gmail.com; **Janet Insardi**, insrdij@hotmail.com. Online news form, <http://www.alumni.cornell.edu/class-notes/>.

85 The Class of 1985 is turning 54. Pretty crazy to think that 36 years ago we all walked into those hallowed halls of Cornell, freshmen at an Ivy League school, and started our college careers. Imagine, what if we had had cell phones back then? Social media? How different our experiences may have been! And how lucky are we that our college lives are not recorded on video?



Class of '83
Our 35th Reunion
Is right around the corner!
June 7-10, 2018

Highlights:

- Current issues panel discussion with '83 classmates
- Meals with new and longtime friends at Klarman Hall, McGraw Tower, and Willard Straight Hall

Like us on Facebook at
www.facebook.com/groups/Cornell1983

Debbie Gelfand Campbell (Somers, NY) is the development coordinator for JDRF Int'l. She bicycled 100 miles for the Ride for the Cure in Saratoga Springs to raise funds for research for Type 1 diabetes for children. **Risa Mish**, MD '88, is the Professor of the Practice of Management at the Johnson Graduate School of Management in Cornell's SC Johnson College of Business. Last year, she was awarded the Core Teaching Award (given by the first-year MBA class to a professor who

nester with husband Jack. Their oldest, son **Jesse '17**, is in grad school at U. of Oregon after graduating from Cornell; daughter Sydney is a junior studying at Ursinus College in Pennsylvania and playing on the volleyball team; and the youngest, daughter Isabella, is a freshman at Colgate. Tara often runs into Cornellians at Cornell vs. Princeton hockey games and recently watched her daughter's volleyball game with **Virginia Scarola** and **Beth Harlow** Reed.

At the end of the summer, Dan took a solo trip to campus while his son attended camp a few hours away. Only a few days before classes were to start, he absorbed the atmosphere of excitement on West and North campuses, as freshmen wandered about getting the feel of the campus. He retraced his walks from Low Rise 9 to classes and athletic facilities; he did the same for walks from DU to campus and to Collegetown. He was disappointed to find that Johnny's is now Korean BBQ, and chose to dine at the Nines. He golfed at the university course, where Coach Baughan's (former football coach) son Matt is the professional. Dan missed having friends with him on the trip, but knows he was able to experience a lot more as a solo traveler. Nonetheless, he plans to bring his son Daniel along with him to experience the Hill someday.

Mark Katz, our delightful *Sun* columnist, reports, "I am alive and well and living in Brooklyn Heights, having departed Manhattan long ago, along with everyone else who was not a banker." Mark has been married for ten years now and believes he may be one of the last members of the Class of '86 to procreate. Apparently, Mark is the only dad in his 50s at second grade drop-off. Professionally speaking, Mark is in his third decade at the helm of the Soundbite Inst., a one-man creative consulting firm, where he takes on various speechwriting, humor writing, and creative content projects for a variety of clients, mostly CEOs and CMOs in media and finance. Mark says his past career as a political scribe is now mostly confined to some light punditry (your correspondent personally thinks our administration needs its own spork jokes). Like so many of us, Mark follows the lives of many classmates on Facebook, and each November he looks forward to sitting among friends when Cornell hockey comes to Madison Square Garden. He is also lucky to share dinner a few times a year with some of the brothers from the now-defunct fraternity of Phi Sig Ep. When he wrote, Mark was looking forward to dinner with his old (Mark's word) roommate **Steve Wells** and friends **David Gruen '87**, MD '91, and **Harris Cohen '87** at Peter Lugar.

Poon-Ming Wong, MBA '89, is doing his part to improve the world. He recently joined United Way Worldwide as vice president, Asia Pacific. After spending more than 20 years in investment banking and working as the managing director of IMC Investments Ltd., he will be encouraging the use of technology to increase the impact of the nonprofit's regional partners and its donors. He's also the proud father of daughter **Zoé '13**. **Glen Coben '85**, BArch '86 (Harrison, NY) is happy to report that his daughter **Maya '21** matriculated in the School of Hotel Administration, now a proud part of the Cornell College of Business. **Julie Bick** Weed writes travel trend articles for the *New York Times* and covers the legal cannabis industry for *Forbes*. How about that serendipitous name for a marijuana business reporter? Julie is currently the president of the Cornell Club of Western Washington, which is lots of fun because so many Cornellians are moving to Seattle to work for companies like Amazon, Expedia, Microsoft, and Starbucks.

Our classmates are working hard to make the world better, fix the world's problems, and, you know, fixing the world's bad grammar and sentence structure. Let's hear about how you are changing the world. Take a minute or two to write one of your class correspondents. ❖ **Toby Goldsmith**, toby.goldsmith@gmail.com; **Nancy Keates**, nancy.keates@wsj.com; and **Michael** and **Lori Spydell Wagner**, mwagner123@gmail.com.

'I returned to competitive figure skating three years ago.'

DIANE WEISBROT WING '88

teaches the required core curriculum), the Apple Award for Teaching Excellence (given by the graduating MBA class), and the Globe Award for Teaching Excellence (given by the graduating EMBA class). "Teaching is an enormous privilege and blessing, especially at our own alma mater," she writes.

Shaz Kahng is awaiting the release of her first novel, *The Closer*, in her series "Ceiling Smasher," which focuses on positive, powerful female leaders. **Marcy Hutchinson** MacGovern writes us from Virginia that she enjoyed traveling to New Zealand, Alaska, and several US cities before moving to Charlottesville to be closer to her 98-year-old mother-in-law. Her daughter graduated from the College of Charleston, and her son is a "Firstie" at West Point. **Julie Frost** Goldblatt (Chestnut Hill, MA) is working for Dean Foods in Boston. Her son TJ is at UMass studying computer science, and her 12-year-old middle schooler misses his brother but likes using his stuff!

In an effort to get more news, I Facebook messaged a bunch of alumni—and I actually got some responses! **Jeanne Varney** is a lecturer of Properties Development and Management for the Hotel school. **Steve Anderson** had a mini-Hotelie reunion in Skaneateles with **Michele Chandler**, **Bob Gilfoil '78**, **Phil '83** and **Yasamin Miller**, **Bill '79**, MBA '83, and **Debbie Kearn Minnock '81**, and **Giuseppe Pezzotti '84**, MMH '96. Steve and his wife, Jeanne, were in Amsterdam, Kenya, Tanzania, Switzerland, and Italy for a month and he will officially join the team of Swensons Drive-Ins in Northeast Ohio as COO.

Bruce "Juicer" **Sandground** says he is working for **Andrew Meltzer** at SSP America at Sky Harbor Airport, in Phoenix, AZ. **Sue Mould** Engdahl has attended two Cornell functions with Bruce and has had Andrew and his family and **Doug Birnie** visit her Rocket Fizz store. Doug apparently won the "salesman of the day" title at Sue's store by selling fidget spinners to the customers. Doug also wrote in that he and wife Mary celebrated their 25th anniversary in Barcelona, saw **Warren Fields** in Boston recently, and chatted with **Victor Tiffany** in Boca Raton. **Mark** and **Jill Fahey Palmerino** tied the knot seven years ago, tailgating at a Cornell vs. Harvard game. True Cornellians!

Ara Daglian sent in a photo of him with **Michael** "Kesey" **Sautkulis '88** and **Matt Miller** having cocktails on the beach. Ara lives in Norwalk, CT, near Kesey and **Chuck Torrance**, and works at the Rockrimmon Country Club. Apparently there was a fall beach adventure that included **Tim Turri**, Matt, and Ara. I feel like I am missing out on this! **Tara Shuman** Gonzalez is now an empty

Eleanor Stevens Dixon has her own business, tech editing for knitwear designers. She also works for a local nonprofit that teaches kids to sail for free. Eleanor has always loved being on stage and recently finished a one-woman play based on the life and letters of Ann Landers, *The Lady with All the Answers* (to rave reviews, I hear!). **Tracey Nichol** Austin and husband Bill just built a new home and celebrated their 25th anniversary. Their daughter is a high school senior and their son is a freshman. Tracey works with Incodema3D, an additive manufacturing company, as a business development rep focused on aerospace. She is enjoying the change from Verizon Wireless for 18 years! She says they see Coach **Mike Schafer '86** and his wife, **Diane (Composti) '86**, and they are "all set for hockey season!"

Thank you to all who responded so quickly to my Facebook request for news! I guess if we had had cell phones and social media at Cornell, things really could have been different in keeping in touch . . . and getting photos better left untaken. Please send any news to: ❖ **Joyce Zerkowitz** Cornett, cornett0667@comcast.net; **Roberta Zwiebel** Farhi, rfarhiesq@aol.com.

86 As I write this, Homecoming is looming but a week from now. While a damp chill should be in the air beckoning alumni to pack sweaters and umbrellas, the weather is not cooperating. The forecast is unseasonably warm for late October in Ithaca. I have to hope that those of you who returned to campus were prepared for sun and temperatures in the mid-70s. I also hope you will let your class correspondents know about it and update us on your lives as well.

Daniel Devine wants us to believe that he has led a boring life since leaving the Hill. He lived in NYC for several years after graduating from the U. of Buffalo School of Law. Not one to have too much spare time on his hands, Dan earned his MBA while working for a variety of pharmaceutical companies. In September 2001, he started his own biotech company; sadly, that was thwarted by the tragedy of September 11. With the help of a Canadian investor, he took his company to Australia and, six years later, despite being the company's only employee, took it public. Dan loved living in Melbourne and now considers it his favorite city on Earth. After five years, he returned home to the US with his son and wife. He took a senior executive job at an Australian company called Mesoblast, with a large New York office. He calls himself the "fix-it guy." Where the CEO sees an issue, he sends Dan in to fix it—whether manufacturing, fundraising, or business development.

87 For the last decade, **Patricia Harney** has worked as the director of psychology internship training at Cambridge Health Alliance/Harvard Medical School. She wrote that one of the great joys of her educational role is the chance to work with doctoral students in psychology, many of whom are Cornell grads. Said Patricia: "Not surprisingly, they are among the absolute best of my students!"

Donna Rau Pierce and her husband visited Peru and Bolivia last year. She wrote that while the "highlight of the trip was hiking Machu Picchu twice, there were many, many breathtaking sights and unforgettable experiences along the journey!" Her son John is a senior at Oberlin College, and son **Matt '20** is a sophomore at Cornell in the Engineering college. **Amy Janower** Weinstein has relocated to Nashville, TN, after spending 12 years back in the NYC area. She wonders if there are any Cornellians in the Nashville area. If so, Amy would love to connect!

Thomas Riford is executive director of the Thomas Kennedy Center in Hagerstown, MD. He says he still does radio news part time, working the 5 to 8 a.m. shift at WJEJ. In the winter, he teaches skiing part time at Whitetail Ski Resort in Mercersburg, PA. He is also an examiner for the eastern division of the Professional Ski Instructors of America. **Amit Batabyal** returned in the fall from presenting research papers at two international conferences, the first in Bhubaneswar, India, and the second in Groningen, the Netherlands. He is the Arthur J. Gosnell Professor of Economics at Rochester Inst. of Technology. His daughter, **Sanjana '18**, is a senior in CALS. Send news to: ♦ **Liz Brown**, etb29@cornell.edu; ♦ **Lisa Burns** Griffin, LAG77@cornell.edu; ♦ **Whitney Weinstein** Goodman, ww5@cornell.edu.

88 Question of the month: What would you do if you had a day in Ithaca? Well, start thinking about your answer because our 30th Reunion is only a few months away! Below are some reflections on this question, and other news from our classmates.

Jay Dubowsky, a cardiologist in New York, reports that his medical practice recently joined Mount Sinai Doctors in Long Island. When he's not working, Jay spends time with his brother, **Scott Dubowsky '91**, and family. "We spent a week on our sailboat with Scott last summer. We traveled from Port Washington, NY, to Sag Harbor, to Essex, CT, and then back to our home port!" Jay remembers the first person he met at Cornell, **Paula Flummerfelt** Guinnip. (Paula, if you are reading this, send us some news!) If he had a day in Ithaca, he would start out with a hike to Ithaca Falls, followed by lunch at Collegetown Bagels, and then a trip to the Farmers Market and a boat ride on the lake.

This past August, **Caryn Abner** Zweig's son, **Harris '21**, joined the Cornell family. Caryn tells us, "He moved into Mary Donlon Hall—wow, it looks almost exactly the same! It was great to see some Cornell alumni and friends and meet their kids who were also there for freshman move-in" . . . including yours truly, class correspondent **Andréa Meadow** Danziger, who was moving in daughter **Sophia '21**. Caryn's ideal day in Ithaca: "I always have a Collegetown Bagel—melted muenster cheese on a sesame bagel. Brings me back to the '80s, before there were so many other choices of toppings and bagel flavors."

Congratulations to **Kenneth** and **Lisa Simpson Sydlow '89**! On September 9, 2017, Kenneth took home his third Emmy award as executive producer for the PEAK TV. He received the award from the Mid-Atlantic

Chapter of the National Academy of Television Arts and Sciences. The Mid-Atlantic Emmy Awards recognize excellence in regional television news, programming, and individual achievement. **Diane Weisbrot** Wing is working part time as a home physical therapist. Her son, David, is a college sophomore, and daughter Kiana is a junior in high school. These days, she enjoys skating, traveling, and taking classes at her synagogue in Southern California. "I returned to competitive figure skating three years ago (my passion, and no I don't get paid—we pay to enter!) and I've competed nationally and internationally." Diane met **Ken Ho '98** and **Dianne Miller '99** at national competitions.

In other career news, **Bonnie Glick** transitioned to her next career as deputy secretary of the Maryland Dept. of Aging. "Hey, we're all doing it!" she writes. Bonnie and her husband, Paul Foldi, became empty nesters this past fall when their younger son, Jonathan, joined his brother, Matthew, at the U. of Chicago. **Chris Porter** writes to us from Buffalo, NY, where he is currently the chief legal officer for the Arc Erie County.

Please watch for notices for our Class of '88 webinar series, made possible by a grant received at last year's Cornell Annual Leadership Conference (CALC). CALC is a fabulous gathering of Cornellians from all generations that is open to all, so mark your calendar for February 1-3, 2018 at the Philadelphia Marriott. We hope to see you there! Your class correspondents: ♦ **Andréa Meadow** Danziger, alm46@cornell.edu; and **Brad Mehl**, bradmehl@gmail.com.

89 Did you just flip to the Class Notes section and page to find '89? I am happy you did because we received a lot of news since the last issue. Please keep sharing and filling our column with fun facts and family and professional updates. Not only is it a joy to read, but it simplifies the writing process!

Last summer, several classmates participated in the on-campus offerings of Cornell's Adult University (CAU). **Timothy Libretti** chose Freedom and Justice in the Western Tradition, and **Mary Riordan** attended the Arts and Crafts Movement in Upstate New York. We received this information from CAU and would welcome hearing more about the experience from participants.

Stephen Scott (scottint@gmail.com) shares, "Without question, my greatest joy in life is my 10-year-old daughter, Reagan. I enjoyed showing her around the Cornell campus a few years ago, when my wife, Beth, had been invited to present at the Hotel school." He recalls the first person he met on campus as **Liam Krauss '88**. And if he had a day in Ithaca, he would certainly "have a burger at the Pines (!) and stroll campus to revisit old haunts and see how the place has changed." **Deborah Goldman** lives in New York City and writes, "While currently practicing commercial real estate law at Joshua Stein PLLC, I was also made co-chair of the commercial leasing division of the New York State Bar Assn., and I became an adjunct professor at Cardozo Law School, teaching real estate transactions." Congratulations, Deborah!

Karen Conant Rindner (krindner@yahoo.com) shares about her recent move, coast-to-coast, with her family. "We relocated from Potomac, MD, to Los Angeles for Steven's work at a private equity firm in Santa Monica. We drove two cars and our dog cross-country over a week, which was a fun adventure, and moved into our new home in Westwood on July 4. I continue to work remotely as general counsel for Fidelis Cybersecurity, which is headquartered in Bethesda. (I finally got a job

close to home and now I live 3,000 miles away!) Our three daughters are adjusting well and loving life in California. Erin just started tenth grade at Windward, a private school in Los Angeles; Emily is a junior at U. of Colorado, Boulder and getting ready to spend next semester in Barcelona; and Elisabeth is starting her first year at UC Santa Barbara, which is now only 90 miles from home! If anyone is in L.A., please give me a shout!"

Jill Kasprowitz Pinnola Vizza finished her EdD at Temple U. in June 2017. She celebrated by following her son, **Joseph Pinnola-Vizza '18**, to the Henley Royal Regatta to cheer on the Big Red rowers. Joseph's lightweight first varsity boat had an undefeated season, winning EARC Sprints and IRA Nationals and finishing in quarterfinals in an open-weight class at Henley. "Spending time getting to know the newest alumni and soon-to-be-alumni was inspiring," Jill says.

Many of us left the Hill as better writers, but some of us turned that skill into published novels. Our classmates **Melissa Borza** and **Chris Pavone** are two such writers. Melissa shared, "I recently had my first novel published. The goal of my book is to promote Science, Technology, Engineering, and Math (STEM). *Fashion Figures: How Missy the Mathlete Made the Cut* tells the story of a middle school-aged girl who loves math and fashion." You can find this book on Amazon. Similar to Melissa's main character, my daughter Jillian McGarry chose to pursue study in fashion design and business; she is in her first year at Kent State U. Fashion School and plans to study at their campus in Florence, Italy, and studio in New York City. I ordered a copy of this book to enjoy with her. *New York Times* bestselling author Chris Pavone writes, "My twin boys just started eighth grade at Riverdale Country School in New York City, and I just finished writing my fourth novel, *The Paris Diversion*, due to be published in late 2018." Twin boys make for full days, I imagine! Chris's first book, *The Expats*, won the 2013 Edgar Award for best first novel by an American author. Thank you for sharing about your family and your new book, Chris. (You just helped me check off one item on my Christmas gift list.)

Thank you all for submitting news. If you never have before, give it a try one of several ways: return the news form you get in the mail, e-mail one of us, use our class Facebook page, or visit www.alumni.cornell.edu/class-notes/. ♦ **Lauren Kidder** McGarry, laurenkiddermcgarry@gmail.com; ♦ **Stephanie Bloom** Avidon, savidon1@hotmail.com; ♦ **Kris Borovicka** Gerig, kgerig@columbus.rr.com; and ♦ **Anne Czaplinski** Treadwell, ac98@cornell.edu.

90 Happy 2018, classmates! On the news front, 2017 was certainly a year of many challenges—especially due to natural disasters across the US. But I have every faith that my fellow Cornellians found a way to rise above in the process of helping their communities recover and rebuild. As of column deadline time in October 2017, many fires are raging in the California wine country. It did my heart good to see that **Thwen** and **Jennifer West Chaloehtiarana** were offering to temporarily house evacuees, as well as transporting donations to shelters housing families burned out of their homes.

A Big Red thank you to the many members of the Class of 1990 who took the time to update us on their news. Our Cornell Fund representative **Michael Karangelen** became CEO of Investindustrial Advisors Inc., a European private equity firm, and is working to build and lead their US operation. He and his wife, **Kerry (Motelson) '08**,

MS '09, are parents to future Cornellians Michael James Karangelen III ("MK3") and Katherine Elizabeth ("the Nugget"), who celebrates her first birthday in April. Staying involved with various Cornell alumni organizations, Michael visits the Ithaca campus 10-15 days each year. Recently, he led the design, construction, and fundraising (\$3.5mm) for Cornell's eHub, <https://www.cornellehub.com/>.

Anne Wilkinson, who grew up in Ithaca, paid a visit to her old hometown last summer with her husband and two sons, aged 11 and 9. "We spent an afternoon on campus, starting with a hike up Cascadilla Gorge, and stopped at a few favorite places. My kids loved the Harry Potter feel of the A.D. White Library, and my youngest was thrilled to find sushi at the Cornell Store cafe." Anne and her family have also enjoyed travels around the world. She was recently promoted to partner and principal at BAMO Inc., an award-winning design firm in San Francisco, and is designing hotels in Bangkok and São Paulo, scheduled to open this year.

Hotellie **Ana Petrovich** joined Rosewood Washington, DC, a year ago as director of human resources and is enjoying being a part of the Rosewood Hotels family. Adds Ana, "This is truly a beautiful property with wonderful associates." Why not stop in and say hello to Ana if you are in the capital? **David Lind** and his wife and two children moved back to the US last July, when he became Syracuse U.'s director of the English Language Inst. David spent 27 years living abroad, including in Spain and Uruguay in recent years. He's looking forward to a trip to Ithaca to walk around campus, visit the libraries, meet up with his old Spanish professor, and have a pizza sub at Louie's Lunch truck.

As much as we all love Louie's and the Hot Truck, I'm not sure what Human Ecology alumna **Debra Wein** would say about pizza subs. As the program director of the Wellness Workdays Dietetic Internship (WWDI), Debra is educating Cornell alums to become the next generation of wellness professionals. The WWDI is a distance-based internship for those interested in becoming registered dietitians. So far, there have been five Cornell HumEc alumni who have participated in the program. Debra is CEO of Wellness Workdays, a company that helps clients such as the Denver Broncos, Cleveland Indians, and Google implement innovative wellness programs that improve employee health while reducing healthcare costs. She is also a dedicated Cornellian who serves as a member of the steering committee and is director of alumnae engagement for the President's Council of Cornell Women. She is also on the Dean's Advisory Council for the College of Human Ecology and

frequently makes presentations to Cornell students and alumni at a variety of events.

Scottsdale, AZ, resident **Halle Levine** Farber is the CEO/founder of Medical Accessibility LLC. "Spurred by those with disabilities who face challenges in their doctors' offices and the need of healthcare facilities to comply with the Americans with Disabilities Act (ADA), my team designed and brought to market an adjustable-height medical exam table with built-in weight scale. Called the UpScale, the exam table lowers to 17 inches off the floor, so a patient can transfer easily to the table without fear of falling. This low height also reduces the risk of staff injury usually caused by lifting and positioning a patient. The UpScale powers up to regular exam height and has a built-in weight scale, so the patient can be weighed while lying on the table. The UpScale has removable transfer bars and even has knee crutches, for accessible pelvic exams. It's really a universal design appropriate for all patients, regardless of disabilities." Great invention, Halle!

I'm ending my column with my annual plugs to volunteer for Cornell. Every January, Cornellians all over the planet engage in Cornell Cares Day. For more information on how to get involved, please visit: <https://psc.cornell.edu/alumni/cornell-cares-day>. This is also the time of year that alumni are busy speaking with applicants to Cornell. There are now Skype committees that allow alumni to reach students outside of Cornell's geographic regions of concentration. If you would like to help, sign up with the Cornell Alumni Admissions Ambassador Network (CAAAN) at caaan.admissions.cornell.edu. On behalf of Uncle Ezra, thank you for giving your time for our alma mater! ❖ **Rose Tanasugarn**, nt28@cornell.edu; **Allan Rousselle**, agr2@cornell.edu.

91 If you are interested in getting involved in any position with our class council, please contact class president **Jana Pompadur** Kierstead (Needham, MA; jkierstead@hbs.edu). Specifically, we are looking for a social media/webmaster to manage the Class of '91 website. Check it out for yourself at <http://cornellclassof1991.com/>, and contact Jana if interested.

So, I, **Tim Vanini** (Ithaca, NY), recently accepted a position at Cornell. I am the corporate relations and career services manager in the Professional Programs and Extended Learning Office in CALS. I will be working with students earning their MPS (one-year program) in securing capstone projects for them and helping them with employment opportunities. I moved down here at the beginning of September, so needless to say it's been a whirlwind. I am grateful to be here. **Rebecca Darien**

Yodzio (Traverse City, MI) just moved from California last year and is the owner of an office supply store.

Debra Squires Lee (Hingham, MA) was recently recognized in the 2018 Best Lawyers in America rankings for her expertise in commercial litigation practice. She practices at Boston-based Sherin and Lodgen.

Andrew Peters (Kew Gardens, NY) released *The City of Seven Gods*. The book was recently honored as a 2017 Best Novel (Horror/Fantasy) in the Killer Nashville Silver Falchion Awards. **Ameena Nalim** (Derwood, MD) is a global public health consultant and a qualitative research expert. She and her husband have two daughters at Cornell (Class of 2018 and 2019).

Voula Saridakis (Chicago, IL) began a new role as curator at the Museum of Science and Industry in November 2016. **Elizabeth Collard Richter** (Huntington, NY) and her husband, **Craig '89**, are thrilled that their daughter, **Sarah '21**, has joined the Cornell community. "She is following in her grandfather **Al Collard '57**'s footsteps and is studying Engineering. She also joined the Cornell Formula SAE race team and is having a ball learning about automotive design (as well as racing the go-karts around the parking lot!). We are looking forward to many fun trips back to Ithaca over the next four years." Elizabeth is still working as a partner in her family's patent law firm, where she's been for the last 21 years.

Allison Lakin writes, "My husband and I have moved to a 40-acre farm in Waldoboro, ME, in order to expand my business, Lakin's Gorges Cheese. We also offer culinary and agricultural skills classes on-site through the winter, as well as farm stays. Next year, we will start selling meat from our pasture-raised livestock. This is what happens when an Anthropology major changes careers from museums to cheese-making and farming."

Matthew D'Amore (Pelham, NY) was recently appointed professor of the practice in Cornell Law School's LLM program at Cornell Tech in NYC. Matthew is extremely excited to be an active part of Cornell's new venture. He and his wife, **Michelle (Badami), MS '93**, "just spent a day in Ithaca at Cornell last week; the weather was stunning. Toured the Johnson Museum (spending most of our time on the second-floor deck), visited several new buildings that didn't exist 20 years ago, and walked to the Dairy Bar for ice cream!"

Keep the news coming, even if you use Facebook! You can send your info via the online news form (<http://alumni.cornell.edu/class-notes/>) or contact one of us directly. Cheers! ❖ **J. Tim Vanini**, lavanooche@icloud.com; **Wendy Milks** Coburn, wmilkscoburn@me.com; **Lori Woodring**, lori.woodring@yahoo.com; or **Joe Marraccino**, Joe.Marraccino@wfaifinet.com.

92 Happy New Year and thanks so much for all the news you submitted in 2017! After 25 years in the catering and special events industry in Chicago, **Jennifer Perna** launched her own consulting business. She says, "Thank you, Cornell Hotel school, for the education!" She is traveling tons (but wants to do more), visiting lots of friends and family, and she even made time to attend our 25th Reunion. When asked who at Cornell had the greatest impact on her, she answered that it was her grandfather Coach Lefty James. He was the head football coach at Cornell from 1947-60. Jennifer loves meeting his former players and hearing stories.

Jackie Schulman Dobranks, DVM '97, took a break from her veterinary practice to launch a Kickstarter campaign in September. The campaign is to help fund and spread the word for a board game she created for kids. Brixiples sparks discussion about ethics, safety, common



CORNELL TEAM & LEADERSHIP CENTER
Since 1997

WE BUILD GREAT TEAMS.

(607) 254-7474 • teambuilding@cornell.edu • ctlc.cornell.edu

sense, and courtesy for 7- to 12-year-olds. Jackie and her husband gave their 8-year-old son the little brother he always wanted and she is enjoying her toddler. She is on the board of the Humane Rescue Alliance in Washington, DC, and completed a graduate certificate in Shelter Animal Medicine. Congrats, Jackie!

Maybe Jackie could send a game to classmate Kelly! **Kelly O'Brien-Fairley** is dedicated to serving children. An elementary school librarian in Geneva, NY, she and her husband just adopted FOUR children from foster care! Their four older children are in their late teens and twenties, "so we decided that we still had room for more. We are now the parents of four boys and four girls." She says her focus is on "raising future adults who are good citizens." Kudos to you, Kelly!

More help for kids comes from **Bill Forbes**. After 18 years with World Vision Int'l, Bill was recently appointed the global lead for Child Protection and Participation and still appreciates the many challenges of supporting people working to end violence against children all over the world. His older daughter is studying at Oxford U. in the UK, his younger daughter is a freshman at Pepperdine U., and his son recently started high school. Bill loves exploring the Northwest US. If he could have a day in Ithaca, he says he would "walk, walk, walk, visit old haunts, and marvel at how long it's been." I hear ya, Bill!

Some of our classmates and their families participated in Cornell's Adult University (CAU) classes on campus last July and/or joined one or more of their study tours to destinations around the world in 2017. These non-credit courses, designed and led by some of Cornell's most gifted faculty, allow alums to enjoy the educational life of our university in the company of other bright, curious, and engaged adult learners. **Philip Hsia**, MBA '99, and **Albert Yeh**, ME '93, both took a class on sailing. **Matthew Hutcheson**, MS '95, participated in the Golf Clinic. **Anita Lee**, JD '98, enjoyed advanced photography. It's not too late to register for summer 2018 CAU on campus, so please visit www.cau.cornell.edu to learn more.

Lastly, here's my semi-annual plug for the Cornell Alumni Admissions Ambassador Network (CAAAN). My husband, **Todd Kantorczyk**, and I volunteer to meet local high school students who are applying to Cornell. We really like helping in this way and invite you again to check it out for yourself in your area (<http://caaan.admissions.cornell.edu>). It's a simple way to give back and spread the Big Red love!

Please share your news! We'd love to hear from you. Feel free to e-mail us or use the online form at: <http://www.alumni.cornell.edu/class-notes/>. Thanks! ♦ **Jean Kintisch**, jmk226@cornell.edu; **Lois Duffy** Castellano, LKD2@cornell.edu.

93 A huge thank you to Class of '93 alumni who attended the joint 2017 TCAM/Homecoming weekend. Gorgeous fall weather, fireworks, tailgating, the Big Red Marching Band, and the winning Big Red football team are just a few of the reasons that **Jessica Graus** Woo, **Theresa Flores**, **Juliette Boone**, MMH '97, **William Andersen**, **Laurie Appel** Barkman, **Matthew Beckerink**, **Cheryl Dowling**, **Constance Austin** Flint, **Gregg Klein**, **Amy Miller** Moore, and **Vincente Stasolla** made their way to "far above Cayuga's waters."

Nancy Thevenin sends her regards! Currently she serves as an international arbitrator and mediator and adjunct professor of the international commercial arbitration course at St. John's Law School. She recently became a general counsel at the US Council for Int'l

Business (USCIB). When asked what she would do if she went back to Ithaca, she said visit the campus, especially Balch Hall. Speaking of, you can visit Balch on June 7-10, 2018 at our 25th Reunion!

Classmates, keep your eye out for messages regarding Reunion. You will find the most up-to-date news at: <https://alumni.cornell.edu/come-back/reunion/classes-groups/class-of-1993/>. You can link to our class, Facebook, and Twitter pages from there as well. Thank you to our Class of '93 Reunion co-chairs, **Lauren Bailyn** Sapira, MBA '94, **Christine Watters** Stuhlmiller, and **Jessica Graus** Woo, for your tireless work. You may contact them with Reunion questions at cu93reunion@gmail.com. Send your news to: ♦ **Theresa Flores**, taf6@cornell.edu; **Mia Blackler**, miablackler@yahoo.com; **Melissa Hart** Moss, melimoss@yahoo.com. Online news form, <http://alumni.cornell.edu/class-notes/>.

94 Greetings from Chicago! As I write this in an unseasonably warm October, the leaves look like they're barely starting to turn. Thankfully, a lot of change is happening in our fellow classmates' lives.

In Lexington, MA, **Rob Stevens** and wife Alison have two children, 9 and 6. "It turns out that life as a 9-year-old is crazy—soccer, piano, Cub Scouts, you name it." Well, as it turns out, life as a '94 alum can be equally intense. Wrote Rob, "I'm at my fifth (!) startup. The company is called Tive, and we help companies keep track of the goods they ship using sensors and software. It's very early (we have eight employees), but it's going well, and I always enjoy the really early part of a startup." It's never too late to go back to school! A different kind of startup is happening for **Chris Laughton**: "Enjoying being a student again! I'm going for a second master's degree; following my MBA from UMass in 2011, I'm pursuing an MS in agriculture and resource economics at UConn part time."

In Oklahoma, **Kevinn Matthews** is the attorney for health and safety at WPX Energy. In his spare time, he is the president of the Cornell Club of Oklahoma and president of the U. of Tulsa College of Law alumni board. He also teaches continuing legal education classes through the U. of Tulsa College of Law. **Sandy Lean** Patterson checked in from California: "I am currently working for a personalized learning public charter school in Santa Barbara, CA. On the side, I am doing some writing and recently published a kid's historical fiction book. It's a time travel adventure called *Lucky 13* set in Cape Cod." In answer to the question "What would you do if you had a day in Ithaca?" Sandy wrote, "Show the campus to my teenagers and convince them to apply." Also living in the Golden State is **Karlene Rogers-Aberman**. After Cornell, she earned her JD from Georgetown U. and is now a partner at the law firm Stephenson Acquistio & Colman. She was named a Southern California "Super Lawyer" for the third year in a row.

Some updates on alums abroad: **Kaila Colbin** sent word from Christchurch, New Zealand, where she lives with her husband and three stepsons. "Working with Silicon Valley's Singularity U. to lead the SingularityU Australia Summit in Sydney next February. I love helping people understand exponential technologies and how we're all going to be affected!" **Sean Alexander**, MBA '01, is still working for Macquarie in Hong Kong. Over the summer, he raised US \$25,000 for the nonprofit Child's Dream—which focuses on health and education for children in Myanmar, Laos, Cambodia, and Thailand—by completing the Ironman Copenhagen. Go Sean! If he had a day in Ithaca, he said he'd "go to the falls."

Peihua Ku, an active Reservist deployed to Bahrain for ten months, works in communications for a Navy/Marine command task force. In answer to the question, "What gives you the most satisfaction in your life these days?" Peihua wrote, "Knowing the work I do matters and is important for the security of this region, though few know where Bahrain is and its significance in the Persian Gulf." If he had a day in Ithaca, he'd "enjoy a nice bottle of wine with friends under the Clock Tower overlooking West Campus." Sounds perfect to us! ♦ **Dika Lam**, dikaweb@yahoo.com; **Dineen Pashoukos** Wasylik, dmp5@cornell.edu; **Jennifer Rabin** Marchant, jar1229@yahoo.com.

95 **Caroline Fox** and husband **David Shechter** both had a great time with Caroline's former roommate, **Sarah Schneider** Cohen, and her husband, Shane, when they visited New York in August. "It's hard to believe that Sarah and I have been friends for 26 years, since freshman year in U-Hall 5, and that David and I have been together for 23 years, since our senior year," says Caroline. Sarah and Shane live in Modiin, Israel, with their five children, and Sarah works as a pediatrician. David is an associate professor in the biochemistry department at Albert Einstein College of Medicine. Caroline is counsel for IBM Watson Health in Armonk, NY. They live in New Rochelle with their three kids.

Steve Miller says he was doing an annual clean-out and found a couple of Cornell T-shirts from the good old days, 22 years ago. He's been in Germany for the past 16 years. "In addition to picking up the language, I also got married and now have two girls. While it isn't quite as much fun as Slope Day, Oktoberfest is pretty fun, and I get to go every year," he writes. He says he still uses those Cornell Engineering skills in product marketing for simulation software at MathWorks. "I get to travel to lots of places," he says. "Having locals show you rafting in India or karaoke in Japan makes for a much better business trip."

Past class president **Alison Torriño French** continues to enjoy life in the Washington, DC, area with husband **Matt**, ME '96, and their children, Sarah, 7, and Ben, 5. She is celebrating her fourth year of being in business for herself with her consulting company, Alto Solutions (www.altosolutionsllc.com), and is continuing her college passion of singing with her a cappella group, On the Verge. Matt is celebrating almost 20 years (how is that possible, they wonder) as a computer scientist for USC's East Coast division of its Information Sciences Inst. After ten-plus years as COO of a Chicago-based investment fund, **Amy Kaplan** Rosenow has turned her frustration at how hard it is to be a working parent into

Return. Reacquaint. Renew.



June 7-10, 2018
classof93.alumni.cornell.edu

her first entrepreneurial venture. Her new company, Jugl, creates software to make it easier to be a working parent. If you feel the pain, check it out at www.getjugl.com.

Patricia Louison Grant has been named senior associate dean of undergraduate programs at Georgetown U.'s McDonough School of Business. Patricia has also served Cornell in multiple capacities, including as CACO board member, Cornell counselor, and Class of 1995 Reunion co-chair. **Tim Peer**, VP of district energy at BOND, was appointed to the board of directors of the Int'l District Energy Assn. (IDEA). He is also an active member of the Cornell Society of Engineers (CSE). **Katherine Vega Stultz** and her family are taking on an expat opportunity in Madrid, Spain, where she will be the GM for Iberia for the Celgene Corp. She has been working for Celgene for 12 years now, committed to cancer drug development.

On behalf of Justin Trudeau, the Prime Minister of Canada, Senator Salma Ataullahjan presented the Government of Canada Sesquicentennial Pin to **Tara Dawood** in recognition for her work to educate young women through her Educate a Girl initiative. **Danielle Wolff** reports that she has been doing a lot of traveling over the last few months, with trips to Vietnam, Cambodia, England, France, Switzerland, and, her favorite, Japan. **Lee Gjertsen Malone** (LeeGjertsenMalone@gmail.com) writes, "My first children's novel, *The Last Boy at St. Edith's*, was published by Simon & Schuster last year, and my second novel, *Camp Griftwood*, is coming out in 2019, also from S&S. I'm currently a freelance writer and editor, and I live in Cambridge, MA, with my husband, Scott, the Boston bureau chief for Reuters, and our 12-year-old daughter." Let us know what is going on in your world! ♦ **Scott Lajoie**, scottlajoie@hotmail.com; **Steven Strell**, strells@mac.com. Class website, <http://classof95.alumni.cornell.edu>. Online news form, <https://alumni.cornell.edu/class-notes/>.

96 Artie Smith is keeping the Big Red running strong! An assistant women's track/cross country coach since 1999, he was promoted in August 2017 to become the **Alan B. '53** and Elizabeth Heekin **Harris** Head Coach of Women's Track and Field and Cross Country.

In this role, Artie follows in the footsteps of his mentors, former head coaches Lou Duesing and Rich Bowman. Additionally, he helps administer the Big Red's summer cross country and track and field camps and is the meet director for Cornell's home cross country and track meets. Artie's now an author also, having written *Lift the Chorus, Speed it Onward: A Celebration of 100 Years of Cornell Track and Field and the TransAtlantic Series*. Published in April 2017, it documents Cornell's long-standing participation in spirited track and field competition with Oxford and Cambridge. Artie serves Cornell off the track as well in his role as a faculty advisor for the College of Arts and Sciences. He lives in Ithaca and can still be reached at acs1@cornell.edu.

From running . . . to recording! **Seth Kibel** has released a brand new album on Azalea City Recordings, titled "Seth Kibel Presents Songs of Snark & Despair." This new album of original tunes, all written and composed by Seth, features talented guest artists, progressive political commentary, dark humor, and much-needed musical therapy for these strange and trying times. The songs on the album traverse a wide landscape of musical styles including blues, swing, klezmer, bossa nova, reggae, and more, and feature the vocal talents of Flo Anito, Black Betty, Billy Coulter, Damon Foreman, David Kitchen, and Chris Urquiaga. It's available for purchase at

www.sethkibel.com, www.CDBaby.com, and pretty much everywhere else fine music is sold on the information superhighway. Seth is married to **Sandy Alexander**, and they live in Pikesville, MD. Catch him at seth.kibel@gmail.com!

Pinar Ustun de Cabrol has taken a new path, too. She and her husband, Charles, have recently moved to London, where they see many friends including her sister, **Idil Ustun Ugur '97**, and **Giovanni Rvedin '97**. Pinar is thrilled to be in the same city with her sister, family, and great friends. Her children, Sinan and Ela, are also happy to unite with their cousins! You can wish Pinar well (or welcome her to London!) at pina_ustun@mac.com. Please send news to: ♦ **Lee Hendelman**, LeeH1818@hotmail.com. Online news form, <http://alumni.cornell.edu/class-notes/>.

97 Happy New Year to the Class of 1997! Here are a couple of updates to start 2018. **Matthew Stauffer** was appointed managing director and head of institutional trade processing at the Depository Trust & Clearing Corp. (DTCC) last June. In this role, he's responsible for integrating DTCC's middle office trade processing solutions as well as leading new product development. Matthew previously served as CEO of Clariant Global LLC, a partnership DTCC launched in 2014 with six founder banks. Prior to that, he was the managing director of strategy and business development and has held senior roles within DTCC's operations, technology, and product organizations. He is also a member of the firm's operating committee.

Alexander Villamar recently joined Howard & Howard Attorneys PLLC, practicing out of the firm's Las Vegas, NV, office. Alexander specializes in commercial and business litigation, insurance defense, personal injury, and appellate law. He practices in both state and federal court and has tried many cases before the American Arbitration Assn. His primary duties consist of handling general litigation matters, including commercial and business litigation. Alexander often works in tandem with in-house counsel and is involved in conducting legal research, drafting pleadings, arguing motions before the court, conducting all manner of discovery, negotiating settlements, drafting settlement agreements, and otherwise preparing a case for trial. He received his JD from the UC Hastings College of Law.

Please take a moment to send us your news: ♦ **Erica Broennle** Nelson, ejb4@cornell.edu; **Sarah Deardorff** Carter, sjd5@cornell.edu. Online news form, <http://alumni.cornell.edu/class-notes/>.

98 Homecoming weekend is a time-honored tradition when the Big Red family of alumni and friends return to campus to reminisce about old times and make new friends. Highlights from this past Homecoming included Cornell beating Brown 34-7 and everyone with "pumped up kicks" at the Foster the People concert at Barton Hall. Missed it? You can always come home! Don't forget our 20th Reunion is coming up in June! Until then, here are some updates from our fellow classmates.

Congratulations! On July 1, 2017, **Alberlyne Harris** married James Woods Jr., and the newlyweds live happily in California. **Nophmas Ann Kositchotitana** and husband **Ronald Chen** are parents to two daughters, Sofie, 9, and Natalie, 6. After spending 11 years in Singapore, they relocated to Los Angeles in 2015. Welcome back! When the CEO of Rochester-based Brothers Int'l Food Corp., **Travis Betters**, reached a

legal settlement with a competitor, he decided to give 100 percent of the settlement to his employees. The company makes fruit products and beverages like Brothers All Natural Freeze-Fried Fruit Crisps and wines under the labels Lost Vineyards and TreeHugger. "I am very fortunate to have what I have and to have good people around me," Travis said, crediting his staff with the success of the company.

Also living in Rochester, **Helene Richards McMurray** and her husband, **Jason '94**, have two children, Aidan, 16, and Cameron, 8, along with a menagerie of pets. Helene is an assistant professor of clinical pathology and laboratory medicine at the U. of Rochester Medical Center. Her work handles testing for organ and bone marrow transplantation. Still at NASA Headquarters in Washington, DC, **Amy Snyder** Kaminski shares, "My work involves encouraging NASA's use of prize competitions open to the public to help us generate ideas and develop technologies that advance our ability to achieve space exploration goals. There is so much enthusiasm, expertise, and creativity out in the world; we want to tap into that, and we find that people are eager to participate with NASA, so it's a really terrific synergy!"

Jason Warshof '97 wrote to us about the passing of his dear friend Dr. **Daniel McMenamin**, who died of ocular melanoma. The Daniel McMenamin Endowment, set up in his honor by friends and colleagues, seeks to improve care, coordination, and collaboration for patients with rare diseases: <https://www.dtmfund.com>.

Thank you for sharing your news with us. You can access the online news form at <http://www.alumni.cornell.edu/class-notes/>. Or please e-mail either of your class correspondents; we would love to hear from you. ♦ **Uthica Jinvit** Utano, udj1@cornell.edu; **Toni Stabile** Weiss, tls9@cornell.edu.

99 Congratulations to **Kelwin Harris** (kelwinharris1@gmail.com), who has been selected as a 2017-18 Marshall Memorial Fellow with the German Marshall Fund of the US. The Marshall Memorial Fellowship (MMF) is the German Marshall Fund's flagship leadership development program.

Created in 1982 to introduce a new generation of European leaders to the US, MMF grew in 1999 with a companion program that began sending emerging leaders from the US to Europe. The German Marshall Fund makes MMF awards to the best and brightest from all sectors, including business, government, and civil society. Selected fellows engage in six months of preparation designed to enhance their understanding of transatlantic relations before embarking on 24 days of policy immersion across the Atlantic. Kelwin will be concentrating on the nexus between equity, inclusive growth, and civic and community engagement. Send your news to: ♦ **Melanie Acostavalle** West, melaniegraycewest@gmail.com; or **Heather Hollidge** Madland, hmadland@gmail.com. Online news form, <http://alumni.cornell.edu/class-notes/>.

00 Happy 2018, everyone! I have some fun updates from our classmates to share this month. Settle in and enjoy!

Cited as a trailblazer shaping the future of wine in America, **Cheryl Stanley** was named to *Wine Enthusiast's* list of the Top 40 Under 40 Tastemakers of 2017. Cheryl is a lecturer in the Hotel school, teaching everyone's favorite reason to venture to the Hotel school, Introduction to Wines, in addition to several other courses. She is also a member of the Society of Wine Educators and the US Bartenders' Guild. Before returning to Cornell,

Cheryl managed inventory for the Wine Cask Restaurant and Store in Santa Barbara, CA, worked as a sommelier for the Four Seasons Hotel in Newport Beach, CA, started her own restaurant consulting company specializing in beverages and service, and was an instructor at the Culinary Inst. of America (CIA) in Hyde Park, NY. In 2015, she was awarded the **Ted Teng '79** Dean's Teaching Excellence Award. Let's raise a glass to Cheryl!

Scott Gescheider was recently promoted to president and CEO of Moana Nursery. He will oversee the entire Moana Nursery organization including nursery growing operations in Canby, OR, three retail garden centers in northern Nevada, and landscape services operating in Nevada and California. Scott previously led the company's landscape division for 12 years. Prior to that, he served in the Navy as a supply officer responsible for the logistics of fast attack submarines. **Meredith Haff Breiland** recently celebrated ten years with Concept2, the rowing company that just launched the new BikeErg—a cycling ergometer. She and husband Erik live in Vermont with their two daughters, Margo, 1, and big sister Elsa, 3. In October, Meredith attended the Head of the Charles Regatta, the world's largest two-day rowing event. In addition to organizing the event for Concept2, she raced in the Senior Master Double, her first time sculling in the event (at Cornell, they rowed in eights, which is a sweep boat), finishing 12th in a 34-team field. Way to go!

Now a full-time author, **Linnea Hartsuyker** recently enjoyed the release of her debut novel, *The Half-Drowned King*, published by HarperCollins, is the first in a trilogy about Viking Age Norway. Linnea and husband **Seth Miller '99** live in New York. **Wilson Barmeyer** was recognized as one of two "Top Authors" as part of JD Supra's Readers' Choice Awards in 2016. Selected from more than 40,000 authors who publish work on JD Supra's legal news platform, Wilson was honored for his writing in the Class Action category. At Eversheds Sutherland, Wilson defends class action lawsuits, complex business litigation matters, and governmental regulatory examinations and audits, with a focus on litigation and regulatory matters involving financial services, life insurance and annuities, and broker-dealers.

Kristen Schroeder reports that she married Ben Wood on June 17, 2017. She writes, "My sister, **Heather Schroeder '03**, gave a beautiful maid of honor toast and we were surrounded by friends and family from both sides of 'the pond.' Ben is a graduate of the U. of Glasgow, and a good contingent of Scottish friends made the trip over. Several Cornell classmates helped us celebrate our special day, including **Valerie Fristachi, ME '00, Toni Santiago** Hollifield, **Debby Levenson, Leslie Pinkham, Sara Robinson, and John and Andrea Clark Yowpa**. Other classes were well-represented by **Renee Ebbert '99, Julie Katz Karp '02, Dianne Miller '99, Seema Prasannakumar '01, and Sandra Wintner '01**. Ben and I honeymooned in Italy and live in the Philly suburbs. We try to catch Cornell sporting events at Penn and Princeton and hope to get back up to Ithaca soon." **Jennifer Rice** Caputo also married recently. She wed in March in a small, private ceremony at her home in Connecticut. Congratulations! Thanks to everyone who shared news. Please send me updates (big or small!) anytime! ❖ **Christine Jensen** Weld, ckj1@cornell.edu.

01 I have a theory: our class is more geographically scattered than previous Cornell alumni generations, in part due to life-changing events like 9/11 and the Great Recession striking during key points in our twenties. This global spread can make it challenging

for us to feel united—and therefore makes this column and our Reunions even more important!

Hopefully you're all keeping June 2021 marked on your calendars for our 20-year gathering—but how about a between-Reunions reunion? We have two options in fall 2018: Homecoming in Ithaca in September, and the Cornell-Columbia football game (followed by the awesome **Sy Katz '31** Parade down Fifth Avenue to the Cornell Club—New York) in November. If you're interested in taking the chill off our long separation with a "BRR"

relocated to Greenville, NC, to start her new position as an assistant professor in health education and promotion at East Carolina U. She hasn't run into any Cornellians yet, but I maintain that we are everywhere—please prove me right and let her know if you're around! My social media stalking—I mean, friendly interest!—reveals that **Angela Ronzio Korch '00** and **Melissa Hantman Pheterson** have updated resumes, too. In Colorado, Angela is now vice president of corporate and mountain finance at Vail Resorts; in Rochester, NY, Melissa is now

'Having locals show you rafting in India or karaoke in Japan makes for a much better business trip.'

STEVE MILLER '95

at one or both these events, e-mail me and we'll work on getting something formally organized!

And now for our news—from farthest away, working our way back up to the Hill. Let's raise two glasses to **Deniz Birinci** in Cyprus, who switched to the private sector last year as communications director for the Basel Group, then welcomed baby girl Olivia. New motherhood has inspired her to take a break from Facebook, but friends can still get in touch via LinkedIn, WhatsApp, and Viber. Family physician **Lenny Lesser** and his wife, Mary, moved to their first house in Oakland and had a baby, Adam James Marc Lesser—unexpectedly born at home! "My medical skills came in very handy," he writes. Lenny works at the quality and value team at One Medical in San Francisco.

Also in the Bay Area, **Christine Vleck** Jensen has worked at Clif Bar for the past eight years, managing the company's shopper marketing program since 2016. She writes that baby Isla Kathryn, born in May, "has been spoiled with lots of Cornell gear from my former classmates." Taking advantage of Christine's sabbatical, the family is spending January and February in Australia and New Zealand—any classmates around? While enjoying old work and new family life, Christine also teaches Pilates classes for fun. She has fond memories of the first people she met at Cornell, including **Jennifer Eng** Shen and **Melanie Woodrow**—who now lives just a few blocks away. If Christine had a day in Ithaca? She would wander around campus and Collegetown, checking out all the changes, "and get an ice cream from the Dairy Bar, of course."

If he had a day in Ithaca, **Jamie Aycock** would "jump on the middle of the suspension bridge and sled down Libe Slope." Until then, he's got his hands full in Houston as a litigation partner at Kirkland & Ellis LLP—and with seven kids! "After having five boys in a row, **Amira (Abuzeid)** and I had two girls, bringing the total to seven," he explains. "Guessing we're in the lead for number of children in our class." You never know, with this unpredictable group! Any competition out there?

During a work trip to Seattle, Jamie recently caught up with **Chris** and **Katie Thyren Schwartzenburg**, among the first Cornellians he met while standing in line at RPU for an orientation event. (Psst, Chris and Katie—see you at a Cornell Club of Western Washington event sometime?) Our class affinity chair, **Deeonna Farr**, has

marketing director for the Quatela Center for Plastic Surgery, while continuing to write about health and fitness for a variety of newspapers and magazines.

Interested in pitching in on alumni outreach, events, fundraising, publicity, and social media for our class? Take a look at our website (classof01.alumni.cornell.edu), like our Facebook page (www.facebook.com/Cornell2001), and follow us on Twitter (@Cornell2001). And if you'd like to join me as a class correspondent or share some news, just find me online or e-mail me: ❖ **Nicole Neroulis** Gupte, NicoleMN6@gmail.com.

02 Byron Hing (blh16@cornell.edu) is a lawyer for Adobe Systems Inc. He and wife Liza recently had their third child, Esther Elizabeth. "She is well loved by her two big sisters, Esme Annabelle and Elsa Josephine," Byron writes. He says that spending time with his family gives him the most satisfaction these days. If he had a day in Ithaca, he would visit his old fraternity house, Acacia, walk across the campus to see the new construction, and buy stuff at the Cornell Store.

Matthew Hirsch (matthewhirsch@gmail.com) writes, "In September, at North America's largest solar industry convention and exhibition, I had the pleasure of hosting a series of on-stage interviews with energy storage thought leaders, including **Farid Dibachi, ME '86**, founder and CEO of JLM Energy." Matthew added, "**Hannah Boal** and I took our two young girls on an epic road trip to eastern Oregon last month to see the total solar eclipse. Unforgettable experience. Wouldn't have missed it for the world." The first person he met at Cornell? "My roommate in Cascadilla, who eagerly introduced me to all the women he'd met on his first day in the dorm. He was motivated out of self-interest, no doubt, but he wound up introducing me to the most amazing person ever (thanks, John)." And what would Matthew do if he had a day in Ithaca? "Look for a time machine so I could see the *Daily Sun* newsroom as it was during the time of the 119th editorial board, grab a bite of food at Oaken-shields (remembering Dave, who used to greet students there), watch Steve Donahue work his magic on the sidelines at a Cornell basketball game (while hoping Brian Earl can eventually fill Donahue's shoes), and find a book to read in Uris Library (still my favorite library of all time)."

Back in September, **Nava Silton** co-wrote and produced an Off-Broadway show that started in September,

based on her comic book series, *Realabilities* (<http://www.realabilities.com>). A story about disability and bullying, *Addy & Uno* features characters with autism, ADHD, and visual/hearing/physical impairments. "Individuals with disabilities are so unseen and unheard across media, especially children's media. We're changing family entertainment, giving a voice to diverse children, and inspiring a new generation of kinder people."

DC. She is a member of the American Inst. of Architects, the US Green Building Council, and the National Trust for Historic Preservation.

Jonathan, JD '07, and Jennifer Hoos Rothberg, MRP '05, welcomed their daughter, Abigail, to the world on April 12, 2017. Big brother Elliott loves making his new baby sister giggle and smile. Jenn just celebrated her 10-year anniversary leading the Einhorn Family

06 Happy New Year from the Class of 2006! We hope your 2018 is looking bright. In class news, **Colleen Herlihy Doyle** is working part time as a speech language pathologist (SLP) at a private practice, Puzzle Pieces LLC. Puzzle Pieces serves children with developmental disabilities in a family-centered therapy approach and also provides trainings and consultations to daycares and preschools. Colleen and her husband, Brandon, have two children, a son, age 3, and a daughter who will soon turn 1. She finds great satisfaction in spending time with her children, and if she had a day to spend in Ithaca, she would spend it swimming in the gorges or going wine tasting.

After 11 years with Hillstone Restaurant Group, most recently as the executive general manager of Rutherford Grill, **Cameron Shaw** is excited to embark on a new career in the wine industry as the director of hospitality and consumer sales for Stewart Cellars in Yountville, CA. She and her husband, Edgar Cruz Ortiz, have a daughter, Talia, who turned 2 in 2017. After years in practice at the Silicon Valley offices of international law firms Morrison & Foerster and Sidley Austin, **Diane Gabl Kratz, BA '05,** reports that she is enjoying practicing law in-house at Seagate Technology in Cupertino, CA, where she is senior intellectual property counsel. Diane enjoys speaking at conferences and gave the keynote speech at IPfolio's October IPforward Dinner: "Strategically Insane: When to Ignore Conventional Wisdom to Win IP Litigation." She was also featured as a panelist at Managing Intellectual Property's Trade Secrets Forum in Palo Alto and the Int'l Intellectual Property Law Assn.'s Annual Meeting in San Jose. Diane's favorite activities include mountain biking, hiking, and wine tasting with her husband, Franz.

Anthony Merlocco recently moved to the South for the first time and is loving it. He lives in Memphis, working in cardiac MRI and pediatric cardiology at LeBonheur Children's Hospital and the U. of Tennessee. He is also enjoying exploring Tennessee and living by the mighty Mississippi, while adjusting to being an attending physician, and is discovering a ton of great music and food in his new city. Anthony's greatest satisfaction right now comes from discussing new diagnoses with families and helping them navigate his hospital and the issues many of their children face. If he had a day in Ithaca, he would visit the McGraw Clock Tower and Uris Library, get drinks in Collegetown, eat a "badass bagel" at CTB, and walk down to the gorges. Send us your news! We love hearing from you. ❖ **Tory Lauterbach, VML8@cornell.edu.**

07 Happy New Year, Class of 2007! Hope everyone had a great holiday season and you're getting a great start to the new year. Any resolutions for 2018?

Just a few updates from you all, so let's get to it. **Adam Hellwig** recently joined Leech Tishman in Skaneateles, NY, as an attorney in their energy and real estate practice groups. Prior to joining Leech Tishman, Adam worked as a sole practitioner at his own title consulting firm, providing oil and gas industry clients with guidance and practical solutions. He was also employed as a title attorney with Pecora & Duke.

Rachel Schell-Lambert (New Orleans, LA) is working at a small, popular restaurant as their pastry chef, making brunch, pizza, and dessert items. She is starting a new bread business and is testing the waters with her products at a local coffee shop. Additionally, Rachel is working with the Food Policy Advisory Council of New Orleans to help influence local programs to help urban and peri-urban farmers grow food and bring it to market.

'Darin Lamar Jones has been hosting private movie screenings and panel discussions for socially important films.'

JEFF KATZ '10

Happy New Year to you all! Please send your news and holiday letters to: ❖ **Carolyn Deckinger** Lang, cmd35@cornell.edu; **Jeffrey Barker**, jrb41@cornell.edu. Online news form, <http://alumni.cornell.edu/class-notes/>

03 **Elissa Downs** wrote to tell us she was "recently hired as an assistant professor in pediatric gastroenterology at the U. of Minnesota." Congratulations, Elissa!

Douglas Wheeler wrote, "Since finishing my MD/PhD I have been a postdoctoral scholar at the Dana-Farber Cancer Inst. and the Broad Inst. in Boston and Cambridge, MA, respectively. I study the mutations that drive lung carcinoma. I married my partner, **Natasha Novikov, MD '15,** in June of this year. We both graduated from Cornell's MD/PhD program in 2015 in NYC. She is a clinical pathologist, and we have two awesome cats." He added that "successful experiments at work and a happy life at home, in no particular order" give him the most satisfaction. Douglas noted that he and Natasha visited Ithaca this summer. "We got Mexican food and margaritas at Agava, walked through some gorges, and strolled around the Arts Quad. If we'd had more time in town, I would've loved to visit some of my favorite professors and see how they've been." This sounds like a lovely time in Ithaca, and Douglas can get a chance to visit those favorite professors at Reunion next year!

Speaking of Reunion, **Rich Chomko** and **Jaime Wasserstrom** Novikoff are busy planning our 15th Reunion next summer in Ithaca! Rich and Jaime shared some of the Reunion plans with **Jaimie Hanlon** and me on the phone this past weekend. Rich and Jaime have exciting events planned for our class, and Reunion is always a good time to reconnect with the Cornell community. We hope to see you back on the Hill in summer 2018.

I look forward to hearing about the great things our classmates are doing via news and notes submissions. Until then, all the best. ❖ **Jon Schoenberg**, jrs55@cornell.edu; **Candace Lee** Chow, lee.candace@gmail.com.

04 **Alexis Cecil**, BArch '04, has been named a senior architect in the Ann Arbor office of Quinn Evans Architects. Alexis completed numerous major projects with the firm, including the renovation of the Howell Carnegie Library in Howell, MI, the restoration of the Colorado State Capitol Dome, and the modernization of the National Academy of Sciences in Washington,

Charitable Trust, and Jon is now senior legal council at Standard Chartered Bank. The Rothbergs continue to live on the Upper East Side of Manhattan.

Congratulations to all the Cornellians celebrating milestones! Please continue to share your news with us. ❖ **Jessi Petrosino**, jessi.petrosino@ey.com. Online news form, <http://alumni.cornell.edu/class-notes/>.

05 During the winter, I am reminded of some of our most picturesque campus scenery. The semi-frozen falls near Beebe Lake and the beautiful white landscape of Libe Slope were amazing consolation prizes as I tried to stay warm and get to class. I never knew falling up a hill was a thing until I lived across the street from the Chapter House and climbing up icy Williams Street was part of my daily winter routine. What are some of your seasonal Cornell memories?

On to the updates. Labor and employment law firm Fisher Phillips added classmate **David Klass** as of counsel in its Charlotte office. His practice focuses on representing employers in a variety of employment matters in state and federal courts, as well as matters prosecuted by the Occupational Safety and Health Administration. Prior to joining Fisher Phillips, David represented Fairfax County, VA, in its Office of the County Attorney. He also practiced employment law for several years at a firm in Virginia and, immediately after law school, clerked for US Magistrate Judge F. Bradford Stillman in the Eastern District of Virginia. David received his JD, cum laude, from Washington and Lee U. School of Law.

Diksha Basu had a busy 2017, to say the least. As you may recall, Diksha's debut novel, *The Windfall*, about a New Delhi family that suddenly comes into a large windfall of money, was published by Crown in June. Since then, her work has received much acclaim from outlets like the *New York Times* and NPR. The novel was also optioned for TV by Paramount TV and Anonymous Content, the same collaboration behind "13 Reasons Why" on Netflix. On top of all of this excitement, she and her husband welcomed a baby girl last spring! Diksha is now working on her second novel.

We would love to hear about your life updates. Send news to your class correspondents or check out the online news form: <http://alumni.cornell.edu/class-notes/>. ❖ **Michelle Wong**, mrw29@cornell.edu; **Johnny Chen**, jc362@cornell.edu; **Hilary Johnson-King**, haj4@cornell.edu.

If she were in Ithaca, she'd visit the libraries, hike the gorges, and eat ice cream from the Dairy Bar!

I'm looking forward to sharing more stories with everyone! Have updates to share? Please feel free to reach out to me or submit online! ♦ **Samantha Feibush Wolf**, srf29@cornell.edu. Online news form, <https://alumni.cornell.edu/class-notes/>.

08 Allison Wing (aaw28@cornell.edu) writes, "In January 2017, I moved from NYC to Tallahassee, FL, to start as an assistant professor in the Dept. of Earth, Ocean, and Atmospheric Science at Florida State U. I study tropical meteorology and hurricanes—and now live much closer to the phenomenon that I study!" A few classmates checked in with short updates: **Ruoxi Lu** (RL273@cornell.edu) recently relocated to Seattle, WA. **Nicole Silver** (silver.nicole@gmail.com) sent word from Brooklyn, NY, where she lives with her husband, Jeremy Kohansimeh. **Christine Liguori** Cedar recently moved to a new home, but is still living in Washington, DC, with husband Derek.

Jenna Bromberg (jenna.kristin.bromberg@gmail.com) is now the director of advertising for Pizza Hut, overseeing all digital brand communications and television advertising for the world's largest pizza brand. She writes, "My husband and I welcomed our first child, Casey, in August 2016! He's now a walking, kinda-talking toddler." The first person Jenna met at Cornell was **Brett Rubin**. "We met on the Class of 2008 forums for incoming freshmen, which was a Facebook predecessor!" What would she do if she had a day in Ithaca? "Eat a bagel." Send news to:

♦ **Elana Beale**, erb26@cornell.edu; **Libby Boymel**, lkb24@cornell.edu. Online news form, <http://alumni.cornell.edu/class-notes/>.

09 Greetings, friends and classmates! With another season upon us, we have heard great news from classmates across the US.

Rajiv Perinbasekar '08 and **Sindri Kinnier** married on April 30 in Washington, DC, supported by their families and friends. Many of the attendees were Cornell alumni, including **Grace Chung An '10**, **Caleb Chan**, **MRP '14**, **Joseph Teirab**, **Alex Reynolds**, **Van-Kim Bui Lin '11**, **Laurence Lin '12**, **Samuel Ramsey '11**, **Paul Liew**, BS '08, ME '09, **Daniel Cox '11** and **Katie Lovett Cox '09**! "We moved to Baltimore, where Rajiv is finishing his residency at the U. of Maryland. Sindri works as an informatics technical advisor at Palladium, managing teams in Tanzania and Uganda," they write. Congratulations to you both!

Michael Wine and wife Rifka wrote from Edgewater, CO, where Michael is preparing to go on a 20-month Fulbright post-doctoral fellowship in Israel, looking at climate change impact on the Jordan River headwaters. Michael and Rifka also recently welcomed their first child, who was just starting to walk when he wrote. Michael notes that if he had a day in Ithaca, he would go swimming in Robert Treman State Park! **Jimmy Suarez** was recently promoted to associate director for diversity initiatives in the undergraduate admissions office at NYU. Congrats!

Pick up a new hobby? Move to a new city or start a new job? Marry the love of your life? As always, we would love to hear from you! Please e-mail me, your faithful correspondent, at: ♦ **Rebecca Robbins**, rsr38@cornell.edu. Online news form, <https://alumni.cornell.edu/class-notes/>.

10 October saw many Cornell celebrations. From the Homecoming game victory to the Int'l Spirit of Zinck's Night, Class of 2010 alumni have been feeling the Big Red spirit.

The celebrations continued with 2010 alumni getting hitched in the presence of friends and family. **Erica Coren**, MBA candidate '18, and **Derek MacKenzie '08** wed in NYC in the company of many Cornell classmates (and older Cornell alumni, such as Erica's parents). **Kristina Moore** and her new husband were married in Washington, DC. The bridal party included several bridesmaids from Cornell who happily attended to the bride on her special day. In Cleveland, OH, class president **Tory Hooker** tied the knot. Cornell guests caught a Cleveland Browns loss at FirstEnergy Stadium before taking part in a huge win for love at the Cleveland Museum of Art.

With football season in full swing, Cornellians have been watching their favorite teams. In its annual installment, **Jeff Bowser** arranged a tailgate and attendance at a New York Jets near-win (i.e., loss) to the New England Patriots. Ten Cornellians came out to cheer on both teams. Congratulations go out to **Lauren Barbato**, who recently became a new homeowner in Berkeley, CA.

Former class president and Cornell all-star **Darin Lamar Jones**, when not working with the chairman of the board at the State U. of New York or delivering sermons as associate pastor at the Greater Allen Cathedral of New York, has been hosting private movie screenings and panel discussions for socially important films. Having previously screened Oscar-nominated *Hidden Figures*, Cornellians and community members came out for the newest screening to watch *Marshall*, a critically acclaimed film about a young Thurgood Marshall, and then listen to panelists discuss the cultural significance and takeaways from the movie. Send news to: ♦ **Jeff Katz**, jak232@cornell.edu; **Amar Kelkar**, ahk24@cornell.edu; or **Rammy Salem**, rms84@cornell.edu. Online news form, <http://www.alumni.cornell.edu/class-notes/>.

11 Hi, Class of 2011! We hope you had a happy holiday season and are enjoying the cool weather. As we celebrate this winter, **Amber Moore** will be preparing for a trip to the Netherlands following her receipt of a Fulbright Distinguished Awards in Teaching grant. Amber will be studying LGBTQ inclusive education, with plans to write a comprehensive study of the best practices, and craft a professional development module to be used throughout teacher networks.

While Amber is traveling abroad, **Laura Santacrose** finds herself back at Cornell. Laura was recently promoted to assistant director of the Skorton Center for Health Initiatives at Cornell Health (formerly known as Gannett Health Services). If that was not exciting enough, Laura is marrying her Cornell sweetheart, **Michael**

Lathrop '12. Many congratulations to Amber, Laura, and Michael! Please send news to: ♦ **Dara Perl**, dmp229@cornell.edu; **Siva Iyer**, si74@cornell.edu. Online news form, <http://alumni.cornell.edu/class-notes/>.

12 **Ileana Betancourt** is a marketer for a quickly growing edtech company in Silicon Valley. Since graduating, she has had the pleasure of working in environmental education, solar, and education again. Ileana moved to Santa Cruz recently and has made a big effort to explore the natural pockets, including the state parks, national parks, national forests, and beaches of California. She loves surfing, hiking, and camping and has run into lots of other Cornellians in the area. If she had a day to spend in Ithaca, Ileana writes that she would go on a nature walk at the Cornell Lab of Ornithology and check out the Andy Goldsworthy egg statue, visit the Farmers Market, go swimming at Buttermilk Falls, reminisce on campus, and grab a bagel at CTB and ice cream at the Dairy Bar with her friends still living in Ithaca.

Anya Gibian is excited to begin her second national tour! After touring North America with *Once* this past year, she is proud to join Roundabout's production of *Cabaret* as a Kit Kat Girl. The tour opens December 28 in Worcester, MA, and tours through May 2018. For tour dates and more information, visit: <http://cabaretmusical.com/>. **Nicolas Martin** shared details of his eventful year, including that he left NYC, got married in Normandy, France, and started an MBA at INSEAD in Singapore.

Keep your classmates up to date on your life post-Cornell by sending any information you would like to share to: ♦ **Peggy Ramin**, mar335@cornell.edu.

13 Happy New Year, everyone! We are officially in our Reunion year (just five months away), and I can hardly wait. Don't forget to mark your calendars for June 8-10, 2018. It's never too early to start making accommodations arrangements! The 2013 Class Council is hard at work ensuring that you all have a fabulous weekend. In the meantime, this column is all about the "Lauras" of the Class of 2013.

Laura Mortelli received her master's in multimedia and now works as a multimedia manager for a large farm in southern Georgia. At the farm, she creates photo and video content, blogs, and writes a newsletter. She recently adopted a German shepherd. Laura often reflects on her time at Cornell—her family even misses it!—and keeps in close touch with all of her college friends. She credits **Mike Van Amburgh, PhD '96**, **Dan Brown, PhD '81**, and Dr. Curtis for having that greatest impact on her academic studies.

Laura Stokes works for Pacify Health, a company she has been with since its inception. She has been integral in forming many of the company's relationships with health-plan organizations, hospitals, research institutions, and community coalitions. Laura has found Pacify Health to be a formative environment for women in technology. She's had the fortune to hire two female friends and be mentored by one of the female leaders of the company. Outside of work, Laura enjoys the outdoors by hiking, swimming, and camping. She remembers meeting her lifelong college friends on move-in day in Dickson, where they bonded over the lack of AC in the middle of summer. **Olivia Walton** continues to be Laura's closest friend. Olivia is a freelance travel writer and photographer, who has traveled to 12 countries in the last two years creating online content for solo female travelers on a budget.

**HAVE PHOTOS
TO SHARE?**

Post them at:
[cornellalumimagazine.com/
photogallery](http://cornellalumimagazine.com/photogallery)

As always, I want to hear what you've been up to since graduating so that YOU can be featured in our columns! E-mail me with news! ❖ **Rachael Schuman**, RASchuman@gmail.com.

14 Happy New Year, Class of 2014! We hope that everyone had a holiday season filled with family, friends, delicious food, and mild winter weather! This past fall, **Josefina Hamren** wrote to tell us that she is working toward an MBA at the new Cornell Tech campus on Roosevelt Island. It's exciting to see classmates taking advantage of the degree programs at Cornell Tech, since the planning and development of that campus was just in its beginning phases during our time at Cornell.

After graduation, **Fiona McCabe** moved to the Arkansas Delta as a part of Teach For America, where she continues to teach at her original placement school. While Fiona enjoys her life in the rural South, she found that going out to eat, which typically involves driving an hour and a half each way, was impractical. So she launched a food-centered Instagram and blog, *Made From Scratch* (@made_fromscratch) to keep her passion for food alive and to push herself to cook different cuisines. She hopes that *Made From Scratch* inspires others to cook adventurously.

Classmates **Kai Keane** and **Joe Nelson** have been working together full time for the past two years on a tech startup out of Washington, DC, by the name of *Agnes.io*. After more than 15 months of development, their team launched a new mobile app this past August that uses artificial intelligence to find and recommend things to do based on an individual's interests. At the moment, they're only focused on the college market and have launched at 20 schools in the Northeast (including Cornell). Finally, there's a single source for knowing what's going on around Cornell—the app already makes available every student organization and boasts the largest collection of events on campus and in the immediate surrounding Ithaca area. It even has a free food filter for those students who are driven by following their gut. Seriously, where was this five years ago?! It's a totally free app, available for download at the App Store and Google Play Store, and has the adorable logo of a cartoon penguin with the tagline: "Waddle you do today?" Visit www.agnes.io for more information or e-mail them at kai@agnes.io or joe@agnes.io.

As always, please send us your news. We love hearing about everyone's accomplishments! ❖ **Samantha Lapehn**, SRL76@cornell.edu; **Tejal Thakkar**, tdt42@cornell.edu. Online news form, <http://alumni.cornell.edu/class-notes/>.

15 Hope you all are enjoying the winter weather, Class of 2015, and that you had a great holiday season with your friends, family, and fellow Cornellians. Your classmates have been up to some amazing things, and here are a few highlights.

Adam Kirsch, MBA '16, joined the mergers and acquisitions team at West Monroe Partners, a consulting firm in NYC. Also, after competing at the Cornell fencing alumni tournament last spring, he ended a mini-retirement from the sport and started training again. **Glen Francisco** is a third-year medical student at the U. of Texas Medical Branch in Galveston, TX. He is loving his clinical work and learning in medical school! **Irene Li '12**, BA '15, joined her sister and brother as a co-founder of Mei Mei Street Kitchen and Restaurant in Boston, MA. Her work landed her a spot on the Zagat's National 30

Under 30 List. In her profile, she emphasized the restaurant's diverse staff—over half of those who work there are women, and 50 percent are people of color.

Rebeca Gallo Lazo is working through her second year as a graduate student at Teachers College, Columbia U., pursuing an MA and EdM in counseling psychology, focused on bilingual Latina/o mental health. In the fall, she did her clinical hours at Children of Promise, NYC, which seeks to end the cycle of incarceration through after-school programs for children and adolescents impacted by the incarceration of a loved one. **Michelle Feldman** matriculated to UPenn School of Dental Medicine in the fall.

Caroline Flax started a new position with a small private equity real estate company, the Meridian Group, doing development. She is working on two big projects in the D.C. area and is really excited about the work they are doing. She also had the opportunity to travel to Venice, Munich, and Berlin last summer and enjoyed learning the history and experiencing new places. As of the fall, **Adam Gianforte** was living in a tent with a homeless community in Chicago for five months, seeking growth and restoration, as well as community building.



Have some news? Did you start a new job or get a promotion? Go on an exciting vacation? Have other things to tell us? Share it all with the Class of 2015. Please send us your updates and we will include them in an upcoming column. ❖ **Haley Velasco**, hav9@cornell.edu; **Ariel Cooper**, alc258@cornell.edu.

16 Hello, classmates! Welcome to another edition of our 2016 Class Notes. As we buckle down for winter, I know many members of our class are busy doing fantastic things in all parts of the world. This fall, I was lucky enough to hear from classmate **Matt Crawford**. I would love to hear from more classmates as you continue your lives away from the Hill.

Matt is working as a games analyst for DraftKings in New York. He tells us more about his position within the fantasy sports company: "I work primarily with our fantasy soccer product. I've been working there for just over a year and have learned a ton about the industry and am working toward growing the popularity of fantasy soccer within the US and beyond!" A major contributor to the Cornell cross country and track teams, Matt continues to run in his free time, while also "playing/watching soccer or doing something else in the great outdoors. Besides that, I like to catch up with friends over a pint or one of NYC's endless food options." Matt also spends his free time playing host to other alumni and visiting Ithaca as often as he can—especially to "get back out on trails for a run with old teammates."

Like many of us, Matt misses the physical proximity of friends and teammates. He writes, "The number one thing I miss about Cornell is having all my friends in the same place. Looking back, it was such a luxury to have everyone living within a two-mile radius. I could walk down the street any day of the week and find some teammates or classmates to relax with. Nowadays, replicating that living situation is looking less and less likely." Thanks to Matt for sharing his news!

Our class column is a great way to stay connected to classmates and other Cornell alumni. To share your news, please send me an e-mail or fill out the online news form (see link below). Your classmates are curious and would love to hear your most recent news! ❖ **Meghan McCormick**, mcm324@cornell.edu. Online news form, <http://alumni.cornell.edu/class-notes/>.



Unparalleled Care.
An unparalleled quality of life.
Come see why we're different.
A UNIQUE ALTERNATIVE TO NURSING HOME CARE.
407 Wyckoff Avenue, Ithaca
257-5777
www.bridgescornellheights.com



Students Aiming for Top Tier Colleges...

Receive strategic advice, tools, and guidance from the nation's premier college consultants, helping students for over 20 years:

DR. MICHELE HERNANDEZ
Former Assistant Director of Admissions at Dartmouth Author of *A is for Admission*

MIMI DOE
Parenting guru, educator & author of *Busy but Balanced*

- Unparalleled success rate
- Advising and facilitating every step of the way
- Lessen stress and increase college choices

Join our small group of students for personal admissions consulting. **Call now** for information.



toptieradmissions.com
781.530.7088
info@toptieradmissions.com

ALUMNI DEATHS

1930s

'34 BS HE—Edna Botsford Hollis, Georgetown, CO, November 24, 2016
'35 BA—Florence Nusim Greville, Charlottesville, VA, January 19, 2017
'37—George W. Lauman, Cornville, AZ, April 25, 2016
'39 BME—William C. Chandler, Red Bank, NJ, January 9, 2017
'39 MA—Nathalie Friedland Gross, Berkeley, CA, July 17, 2017
'39 BCE—Harvey McChesney Jr., Bellport, NY, July 8, 2017

1940s

'40 BA—Robert W. Morrison, Hunt Valley, MD, December 16, 2016
'41 BS HE—Ruth Marshall Kibbey, Northport, AL, August 11, 2017
'42—Joseph F. Daino, Ithaca, NY, June 28, 2017
'42—Phoebe Moore Parr, LaFayette, NY, July 2, 2017
'42 BA—Eustace E. Reagle Jr., Naples, FL, February 21, 2017
'42, BS Ag '43—Samuel Rieger, Kenmore, WA, November 26, 2015
'42 BS Ag—Florence Molien Sable, Columbia, MO, April 30, 2017
'42 BA—Beryl Cooke Wilson, Jacksonville, FL, December 27, 2016
'43 BA, MD '47—Susannah Krehbiel Horger, Delray Beach, FL, August 13, 2017
'43 BS Hotel—John A. Vanderslice, Gibsonia, PA, December 12, 2016
'43 BS Ag—Sylvia Lewis Wilson, Atlanta, GA, January 28, 2017
'44, BA '48—William C. Boyne, Rochester, MN, August 9, 2017
'44—Quentin E. Grant, Washington, DC, May 26, 2017
'44—Lucille Jones-Grey Halifax, Venice, FL, June 8, 2017
'44 BA—Edith Kelsey Lewis, Columbia, MD, January 8, 2017
'44 BME, PhD '49—Franklin K. Moore, Ithaca, NY, November 21, 2016
'44, BS HE '43—Sara Storm Shoemaker, Pocomoke City, MD, April 6, 2017
'44 BME—Seymour L. Spira, Paramus, NJ, July 28, 2017
'45, BA '44, MA '48—Priscilla Okie Alexander, New Haven, CT, January 19, 2017
'45, BCE '47—Alfred R. Goldstein, Sarasota, FL, June 26, 2017
'46, BA '47—John S. Heldman, Cincinnati, OH, October 17, 2016
'46, BS HE '45—Elda Barnum Loomis, Clymer, PA, January 14, 2017
'46, BA '45, MS '47—Shirley Crafts Rosser, Parker, CO, July 5, 2016
'46 DVM—William G. Ryan, Portland, ME, December 10, 2016
'46—Robert A. Segal, Palm Beach Gardens, FL, June 20, 2017
'46 BS Nurs—Louise Makutenas Yusko, Pitman, NJ, January 30, 2017
'47, BME '46, MME '50—Owen J. Black Jr., Southport, CT, February 10, 2017
'47 BS HE—Carol Slocum Buschner, Pocasset, MA, December 27, 2016
'47 BA—Walter E. Cohan, Vero Beach, FL, August 6, 2017
'47, BME '49—Paul E. Harmon, Manlius, NY, December 11, 2016

'47 MD—Charles A. LeMaistre, San Antonio, TX, January 28, 2017
'47 BS HE—Lee Gorton Spiece, Tucson, AZ, July 1, 2017
'47, BME '46—Paul C. Warner, Saratoga, CA, September 15, 2015
'47 BA—Patricia Minken Weiss, New York City, May 31, 2017
'48, BA '49—Robert T. Dann, Concord, NH, February 6, 2017
'48 BA—Gifford B. Doxsee, Athens, OH, July 16, 2017
'48 BS Ag—Barbara Borden Floyd, Cherry Hill, NJ, December 2, 2014
'48 BS ORIE—Bernard R. Gold, Mentor, OH, August 31, 2016
'48 BA—Clarine Capuzzi Hall, Winnetka, IL, August 6, 2017
'48—Ralph G. Joseph, East Hampton, NY, June 16, 2017
'48 BS ORIE—Robert J. Marshall, Bella Vista, AR, July 30, 2017
'48 BS HE—Claire Girard Peterson, Santa Clara, CA, June 14, 2017
'48 MD—R. A. Rees Pritchett, New York City, March 27, 2017
'48 BEE—John M. Ross, Wickenburg, AZ, December 15, 2016
'48 BME—Ansley W. Sawyer Jr., Nantucket, MA, February 23, 2017
'48—William M. Seymour Jr., Hillsdale, NY, June 9, 2017
'48 LLB—Jack F. Sinn, Point Pleasant, NJ, December 8, 2016
'48 BA—Alan O. Sykes, Cary, NC, January 23, 2016
'48 BA—William E. Tuttle, Wilton, CT, September 30, 2016
'49 BA—Norman L. Avnet, Pittsfield, MA, January 13, 2017
'49 BS Ag—Leonard T. Borden, Easton, NY, June 15, 2017
'49 BA, MD '52—William L. Craver, Canandaigua, NY, February 1, 2017
'49 BA—Mimi Semmes Dann, Memphis, TN, July 29, 2017
'49 MD—Thomas L. Doyle Jr., Forest Hills, NY, February 10, 2016
'49 BA—Mary Lou Dorward Erdman, Niskayuna, NY, January 24, 2017
'49 BS ILR—Sydelle Hamburg Hirsch, Pompton Plains, NJ, November 27, 2016
'49 LLB—James M. Kieffer, Rochester, NY, December 17, 2016
'49, BS Ag '50—Peter J. Potorti, Ithaca, NY, February 12, 2017
'49 BS ORIE—James B. Schryver, Fall River Mills, CA, January 11, 2017
'49 BEE—Henry W. Wittmann, Lancaster, PA, August 18, 2017

1950s

'50 BS HE—Doris Van Eps Burton, Schenectady, NY, March 26, 2017
'50 BA—George B. Cammann, Darien, CT, August 15, 2017
'50 MBA—John A. Christnacht, Louisburg, NC, July 2, 2016
'50—Helen Eaton Culbertson, Lakewood Ranch, FL, June 24, 2017
'50 PhD—Ezra W. Geddes, Fremont, CA, January 12, 2017
'50 BS Ag—Charles W. Herring Jr., Otego, NY, January 11, 2017
'50, BS Nurs '51—Jean Dulin Kiewer, Corvallis, OR, February 5, 2017

'50, B Chem E '51—Robert J. McLachlan, Martinsville, VA, July 11, 2017
'50 MS Ag, PhD '52—Lyle E. Nelson, Starkville, MS, July 27, 2017
'50 JD—William D. Peek, Basking Ridge, NJ, November 1, 2016
'50 BS Ag, MEd '59—Van R. Powley, Glassboro, NJ, October 28, 2016
'50 BCE—Robert W. Purple, Canandaigua, NY, February 16, 2017
'50 DVM—Stewart R. Rockwell, Emmaus, PA, November 29, 2016
'50 BA—Jerome A. Shaffer, Storrs Mansfield, CT, November 17, 2016
'50 B Chem E—Carl G. Strub, Willow Street, PA, July 17, 2017
'50 BA, PhD '53—Raymond R. Walsh, Glen Carbon, IL, February 1, 2017
'51—Ralph L. Allen, Port Ewen, NY, July 14, 2017
'51 BS HE—Barbara Beyrent Bassett, Fremont, NH, January 14, 2017
'51 JD—Frank C. Bowers, Marlton, NJ, January 1, 2016
'51 BS Hotel—Robert G. Hunt, Rowlett, TX, December 17, 2016
'51 BA—Demaris Blythe Matteo, Dobbs Ferry, NY, August 9, 2016
'51 BS Hotel—Rollin H. Teare, Naples, FL, March 6, 2017
'51 BS Nurs—Anna Mae Gallert Van Doren, Syracuse, NY, August 11, 2017
'52 DVM—John H. Baldwin, Greene, NY, July 29, 2017
'52 BS HE—Mary Shear Brennan, Schenectady, NY, August 16, 2017
'52 BA—Robert J. Eberhart, Halfmoon Township, PA, August 25, 2017
'52 BEE—John J. Ferrante, Ormond Beach, FL, February 11, 2017
'52 MS, PhD '54—Virginia Rogers Ferris, West Lafayette, IN, August 13, 2017
'52 MILR—Thomas T. Johnston, Charleston, SC, January 31, 2017
'52 BS Ag—Peter C. Shuster, Seneca Falls, NY, December 27, 2016
'52 MA—Betty Hilt White, Hammondsport, NY, August 9, 2017
'53-54 SP Ag—Robert K. Brockway, Ward, AR, June 14, 2017
'53 BS HE—Dana Furth Castle, Akron, OH, January 8, 2017
'53, BA '54—Robert E. Dailey, Osprey, FL, February 20, 2017
'53 BA, MBA '54—Harlowe Hardinge, Mercer Island, WA, August 23, 2017
'53, BS Ag '54—Charles R. Osterhoudt, Genoa, NY, December 28, 2016
'53-54 SP Ag—Paul B. Robison, Groton, NY, June 30, 2017
'53 BS Ag—Ara A. Sheperdigian, Mt. Pleasant, MI, June 29, 2016
'53 BA—Samuel Wagonfeld, Denver, CO, January 24, 2017
'53 PhD—Harold F. Webster, Schenectady, NY, January 19, 2017
'54 DVM—Nicholas Berry, Syracuse, NY, July 26, 2017
'54 BS Ag—Barclay K. Brown, Santa Cruz, CA, November 16, 2016
'54 BA—Pierre C. Dussol, Minnetonka, MN, October 31, 2015
'54—Helen Welsh Hardy, Glen Arm, MD, July 27, 2016
'54—Peter H. Model, New York City, June 9, 2017



GATEWAY COMMONS

LUXURY AND EFFICIENCY COMBINE

Gateway Commons is downtown living at its finest. With 25 luxury apartments, nearby Six Mile Creek, restaurants a walk away and onsite parking, this LEED silver certified green building offers all you need and more.

Call us to schedule a tour
607.273.1654
www.travishyde.com



Advertise in CAM's Food & Beverage Special Section May/June 2018 issue



Space reservation:
March 15, 2018

Contact Sandra Busby
SLB44 @cornell.edu
800-724-8458 x23

To access the full-text Alumni Deaths section,
go to: cornellalumnimagazine.com
("Alumni Deaths" under the CURRENT ISSUE tab).

- '54 BA—William C. Romell, Rocky River, OH, December 13, 2016
- '54 BS Hotel—Henry E. Thering, Anderson, IN, August 21, 2017
- '54, BME '55, MBA '59—James S. Weaver Jr., Naples, FL, July 31, 2017
- '54 PhD—William E. Werner Jr., Carlinville, IL, April 16, 2017
- '55 BS HE—Mary Ann Meyer Adams, Getzville, NY, February 1, 2017
- '55 MBA—James I. Barbier, Bay City, MI, April 29, 2017
- '55 MBA—Donald C. Bryk, Roslyn Heights, NY, December 9, 2016
- '55 LLB—John J. Considine, Pittsford, NY, October 16, 2016
- '55, BCE '56—Charles S. Fiske Jr., Monkton, MD, May 4, 2017
- '55 MILR—R. Alan Graves, Aurora, IL, November 27, 2016
- '55 BA—Morton P. Marts, Albuquerque, NM, January 11, 2017
- '55 PhD—Roy L. Millar, Prairie Village, KS, August 18, 2017
- '55 MD—Franklin H. Pfeifferberger, Sarasota, FL, January 16, 2016
- '55 BS Ag—Gerald J. Rosie, Carlisle, PA, August 24, 2017
- '55 BS HE—Sandra Chachkes Temkin, Rochester, NY, April 7, 2017
- '55 BS Hotel—A. Richard Triebel, Glen Ellyn, IL, June 20, 2017
- '56 MS, PhD '57—William J. Chancellor, Davis, CA, February 16, 2017
- '56 BS Hotel—Joseph S. Crisanti Jr., Salisbury, MD, February 28, 2015
- '56 MA—Barbara Angle Haber, Cornwall, PA, January 3, 2017
- '56 MA, PhD '59—Robert E. Scholes, Barrington, RI, December 9, 2017
- '56 BS Hotel—E. Baxter Webb, Palm Beach, FL, June 10, 2017
- '56, BEE '57, MBA '61—George C. Wiltsey, Woodland Hills, CA, December 7, 2016
- '57 BS Ag—William H. Brown, Palm Bay, FL, December 31, 2016
- '57, BCE '59—Victor Noubleau, San Salvador, El Salvador, February 14, 2017
- '57—Peter K. Sour, Sewickley, PA, July 6, 2017
- '57, BME '58, MBA '59—Albert E. Suter, Ballwin, MO, June 29, 2017
- '57 BS HE—Mary Lou Fleming Veit, Clifton Park, NY, November 4, 2016
- '58 BS Ag, MS Ag '59—Majid G. Al-Khazraji, State College, PA, December 29, 2016
- '58 BS HE—Margaret Giles Buchanan, Kill Devil Hills, NC, August 1, 2017
- '58 BA—Lawrence H. Kaufman, Golden, CO, November 8, 2016
- '58 BA, MA '71—Mary Ketchem Larkin, Fuquay-Varina, NC, March 4, 2017
- '58 LLB—Robert L. Maider, Gloversville, NY, February 2, 2017
- '58 NFS—Robert E. Stetekluh, Arlington, VA, July 9, 2017
- '58 MS—Eugene G. Todd, Rancho Palos Verdes, CA, May 31, 2017
- '58 PhD—H. Frank Way, Pasadena, CA, December 4, 2016
- '58 BS HE—Georgia Watson Willis, Austin, TX, August 18, 2016

- '58 DVM—Donald O. Wirth, Westhampton, NY, July 3, 2017
- '59 BA—Eugene A. Abramson, Hingham, MA, September 24, 2016
- '59 BS HE—Sally Wheaton Gillan, Pittsford, NY, April 7, 2017
- '59 MS HE—Audrey G. Guthrie, Roanoke, VA, August 7, 2017
- '59 PhD—Douglas C. Maplesden, Santa Fe, NM, July 24, 2017
- '59 LLB—David S. Ritter, Middletown, NY, August 4, 2017
- '59—H. Donald Scott, South Chatham, MA, July 2, 2017
- '59 MBA—Glenn A. Wesselmann, Bethlehem, PA, January 27, 2017

1960s

- '60 MEd, EdD '67—Jackson O. Hall, Fort Myers, FL, December 23, 2016
- '60 BA, MD '64—David M. Heimbach, Kula, HI, August 7, 2017
- '60 BS Ag—Robert C. Herrick, Trumansburg, NY, July 24, 2017
- '60 BFA—Margo Hicks Newhouse, Hollywood, MD, July 12, 2017
- '60 PhD—Richard Scarpellino, Marion, MA, August 12, 2017
- '60 BA—Steven Zax, Los Angeles, CA, January 8, 2017
- '61 BS Hotel—Raymond L. Campbell Jr., Southport, NC, April 25, 2016
- '61 BS Ag—Ann DeLill-Johnson, Sitka, AK, December 26, 2016
- '61 BS HE—Mary Jane Quinby Faust, Niagara Falls, NY, November 15, 2016
- '61 BA—Marshall P. Katz, Pittsburgh, PA, July 18, 2017
- '61 BA—Robert B. Millman, New York City, August 14, 2017
- '61—Merral B. Neely, Charlotte, NC, June 12, 2017
- '61 MA—Elmer P. Wolfenden, Wesley Chapel, NC, December 1, 2016
- '61 PhD—Robert W. Wood, Gaithersburg, MD, July 26, 2017
- '62 BS HE—Diane Handy Leach, Schaghticoke, NY, February 20, 2017
- '62 MS Ag—A. Thomas McMillan, Ithaca, NY, November 11, 2016
- '62, MEd '64—Edmond W. Miller Jr., Utica, NY, August 4, 2017
- '62 MILR—Hugh R. Roberts Jr., Warrensburg, MO, July 5, 2017
- '62 BCE—Charles M. Streeter Jr., Elmira, NY, August 8, 2017
- '63 BA—Beth Davis Karren, Piedmont, CA, August 8, 2017
- '63 BS ILR—Jung Leong, Shalimar, FL, August 6, 2017
- '63 MAT—James L. Shinn, The Dalles, OR, June 8, 2017
- '63 JD—Roy J. Stewart, Annandale, VA, April 10, 2017
- '63 LLB—Elizabeth Palewski Wellington, New Hartford, NY, December 13, 2016
- '64, BEE '65—Richard H. Collins, Baldwinsville, NY, August 3, 2016
- '64, BArch '65, MArch '69—Jack C. Dobson, Newburyport, MA, June 1, 2017
- '64 PhD—James W. Kimbrough, Sorrento, FL, January 21, 2017

'64, BME '65, MME '66—William B. Moore, Harleysville, PA, April 1, 2017
 '64, BArch '65—Leonard B. Richards III, Oakmont, PA, July 27, 2017
 '64 BS Ag—Gerald E. Schopinsky, Westerville, OH, December 7, 2016
 '64 BA—Alan D. Sisitsky, Springfield, MA, July 7, 2017
 '65—Donald W. Hall, Lake Worth, FL, June 28, 2017
 '65, BS ILR '66—Stephen R. Kellert, New Haven, CT, November 27, 2016
 '65, B Chem E '66—William J. Marble, Rocklin, CA, March 20, 2017
 '65 BS Ag—Rodney M. Roe, Horseheads, NY, May 26, 2017
 '65 BA—Jerry E. Sobel, Cambridge, MA, August 10, 2015
 '66 BS Hotel—Edward J. Casey Jr., Elmira, NY, December 18, 2016
 '66 BA—Kenneth R. Diehl, Durham, NC, June 10, 2017
 '66 BA—Stuart S. Peterfreund, Cambridge, MA, July 19, 2017
 '66 BS Ag—Harold L. Roberts, Rensselaer, NY, August 15, 2017
 '67 BA—Katrina H. Clark, New Haven, CT, August 25, 2017
 '67 BA—David E. Levy, Nevada City, CA, June 2, 2016
 '67, BME '71—John S. McLaughlin, Leicester, VT, April 13, 2017
 '68 BS Hotel—Hollister H. Moore, Philadelphia, PA, July 31, 2017
 '68 JD—William B. Rozell, Juneau, AK, June 29, 2017
 '69 PhD—Paul C. Eggleston, Redmond, OR, March 28, 2017
 '69 PhD—Richard J. Gagan, Asheville, NC, February 23, 2017
 '69 BS Nurs—Barbara Grubb Kirtland, Franklin, PA, July 26, 2016

1970s

'70 BFA—Gail W. Gorlitz, Washington, DC, July 17, 2017
 '71 BS Ag—John F. Billington, Florence, NY, December 14, 2016
 '71 BS HE—Nancy Korba Henion, Ithaca, NY, December 10, 2016
 '71 MS ORIE—Jean E. Lanier, Paris, France, July 19, 2017
 '71 PhD—Margaret Cormeny O'Brien, Jacksonville, FL, May 19, 2017
 '71 MEE—Allan H. Steinfeld, Mertztown, PA, January 24, 2017
 '72, BA '71—Vincent A. Burke, Mullins, SC, December 24, 2016
 '72 PhD—Marilyn A. Menegus, Rochester, NY, March 20, 2017
 '72 PhD—Dennis J. Rygiel, Auburn, AL, August 8, 2017
 '74 BEE—Keith R. Dowling, Merrimack, NH, April 3, 2017
 '74 BS Ag—Larry H. Miller, Grand Rapids, MI, August 5, 2017
 '75 MS Ag, PhD '80—Jack W. King Jr., Dillingham, AK, January 31, 2017
 '76 BS Ag—Margaret Hagin Dillon, Questa, NM, December 11, 2016
 '76—Arthur L. Kennedy, Syracuse, NY, June 27, 2017
 '76 MPS—Phyllis A. Patrick, Southport, NC, April 12, 2017
 '76 BS Nurs—Helen Otterson Rodde, Napa, CA, December 31, 2016
 '76 BA—David N. Van Leeuwen, Valatie, NY, August 8, 2017
 '77 BA—Susan Seidler Chambers, Hamden, CT, July 18, 2017

'77 BS Ag—Robert S. Hayward, Columbia, MO, April 18, 2017
 '77 BS ILR—Jonathan P. Levine, Northbrook, IL, September 28, 2014
 '77 MBA, MA '80—William L. Withuhn, Burson, CA, June 29, 2017
 '78 BS Hotel—Kathryn Ingram Klein, Plano, TX, January 14, 2016
 '78 BS Ag—Russell L. Mills, Webster, NY, November 24, 2016
 '78 PhD—James B. Stimmell, San Mateo, CA, July 7, 2017

1980s

'81 BA—David G. Giovacchini, Ebensburg, PA, November 5, 2016
 '81 MA—David W. Kraft, Princeton, NJ, February 18, 2017
 '81 MS—Michael Kurkowski, Brooklyn, NY, May 14, 2017
 '81 MS Ag, PhD '85—Eugene L. Madsen, Freeville, NY, August 9, 2017
 '81 BS HE—Karia Stevens Roof, Westport, CT, February 16, 2017
 '82 BS, M Chem E '83—Natalie A. Dick, Ithaca, NY, February 5, 2017
 '82 MA, PhD '84—Darryl L. Roberts, Durham, NC, November 30, 2016
 '84 MCE, PhD '86—Timothy A. Cohn, Reston, VA, February 20, 2017
 '85, MS Ag '89, PhD '93—George Aditjondro, Palu, Indonesia, December 10, 2016
 '85 MILR, PhD '95—Valerie Kennedy, Coventry, CT, December 14, 2016
 '86 BEE, MEE '87—Robert H. Barber, Clayton, NY, July 29, 2017
 '86 MBA—Warren O. Fuller, Morris Township, NJ, July 31, 2017
 '86 BS Ag—Philip J. La Padula, Ithaca, NY, November 25, 2016
 '87 BS Ag—Susan M. Aronica, Williamsville, NY, February 9, 2016
 '88 MS Ag—Linda Yee Chu, East Brunswick, NJ, December 12, 2016
 '88 BS Ag—Eric Gunther, Farmington, ME, January 1, 2017

1990s

'90 BS ILR—Caryl Sidle Arsenault, Brooktondale, NY, August 13, 2017
 '92 MS—Darol Chamberlain, Ithaca, NY, August 5, 2017
 '94 MA, PhD '00—Jeffrey A. Hadler, Berkeley, CA, January 11, 2017
 '94 BA—James A. Shyne, Washington, DC, February 3, 2017
 '94 MBA—Andrew P. Woods, Overland Park, KS, August 17, 2017
 '97 BS Ag—Sara M. Kelley, Longmont, CO, April 3, 2017
 '97 JD—Matthew B. Landon, Fairfax, VA, August 1, 2017
 '97 BS ILR—Elaine K. Liu, Foster City, CA, July 10, 2017
 '97 BS Eng—Christopher G. Weisz, Bedford, MA, August 24, 2017
 '99 MA—William E. Stark, Minneapolis, MN, August 12, 2017

2000s

'05 MBA—Peter J. Fitzpatrick, Darien, CT, January 28, 2017

2010s

'15 MS, PhD '16—Ian Lenz, Ithaca, NY, October 26, 2016
 '17 ME—David Zamos, Kent, OH, June 7, 2017

CLASSIFIEDS

Employment Opportunities

EXECUTIVE ASSISTANT, New York—Highly intelligent, resourceful individual with exceptional communication skills and organizational ability needed to support a busy executive. Primary responsibilities include coordinating a complex schedule, assisting with travel, and providing general office help in a fast-paced, dynamic environment. An active approach to problem-solving is essential. Prior experience assisting a high-level executive a plus. We offer a casual atmosphere in a beautiful space, working as part of an extraordinary group of gifted, interesting individuals.

This is a full-time position with excellent compensation and benefits, as well as significant upside potential and management possibilities. Please email your resume and cover letter to hlparecruit@gmail.com. Please note that, due to the high number of respondents, we will unfortunately be unable to reply to every inquiry.

FAMILY ASSISTANT, HOUSING INCLUDED, NEW YORK

Devoted professional couple seeks highly intelligent, amiable, responsible individual to help with the day-to-day execution of a complex family schedule, school drop-offs and pick-ups, homework, research projects, and various other activities. Light cleaning, some meal prep, and some pet care for the lovable family dog will also be expected. Excellent compensation package will include rent-free, one-bedroom apartment in a luxury, doorman building, excellent hourly compensation, and full benefits including healthcare and four weeks paid vacation. This is a year-round position for which we would ask a minimum two-year commitment. If interested, please submit cover letter and resume to liveinmt@gmail.com.

Personals

SMART IS SEXY

Date fellow graduates and faculty of the Ivies, Seven Sisters, MIT, Stanford, medical schools and some others. More than 5,500 members. All ages.

THE RIGHT STUFF

800-988-5288 www.rightstuffdating.com

WHERE IVY LEAGUE AND OXBRIDGE PEOPLE FIND LOVE. A decade of successful matchmaking. BluesMatch.com.

LOOKING FOR a long-lasting romantic relationship? Be introduced to successful, cultured professionals in the NYC area. Comprehensive individualized matchmaking; www.meaningfulconnections.com; (212) 877-5151.

Commercial Warewashing Equipment



Robert A. Cantor '68 Chief Executive Officer	Arl B. Cantor '05 President
Rich Garlick '68 Government Sales Specialist	Kevin Bennett '95 Director of Operations

6245 State Road • Philadelphia, PA 19135
 800-344-4802 • Insingermachine.com

Advertise in CAM's Summer Programs & Sports Camps Special Section

Mar/Apr 2018 issue

Contact Sandra Busby:
SLB44@cornell.edu



Historic Moments

Remembering Martin Luther King Jr.'s visits to the Hill

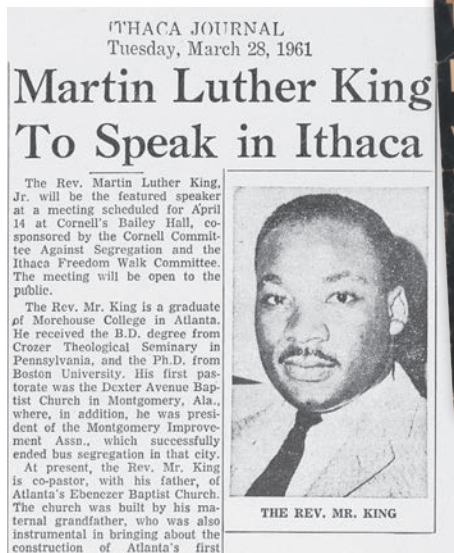

SPREADING THE WORD (clockwise from left): An *Ithaca Journal* story announcing King's 1961 visit; a poster for that talk; King (second from left) in front of the Straight; and Edwards (left) and Marantz in the 1962 *Cornellian*

Among the thousands of documents in the archives of the Martin Luther King Jr. Center for Nonviolent Social Change is a yellowed paper listing the people who had breakfast with the legendary civil rights leader on Sunday, November 13, 1960. It bears fifteen names—all of them Cornell students who had the good fortune to share a meal at the Statler Hotel with one of the most prominent and beloved figures in American history. “I was very impressed, and I think the other people who were there were similarly impressed,” one of those students, Paul Marantz '62, reflected in his diary a few days later. “He spoke to us about the use of nonviolence . . . [and] appeared dedicated, capable, and patient.”

This year marks the fiftieth anniversary of King's assassination on April 4, 1968. Inevitably, that milestone will spur a national reflection on his life and legacy—but few people, even many Cornelliens, may realize that among the hundreds of speeches and appearances that King made during his lifetime are two visits to the Hill. In November 1960, he delivered a Sunday sermon in Sage Chapel; the following April, he was the featured speaker at a civil rights fundraiser in Bailey Hall. “The breadth of life is the outward concern for the welfare of others,” King said on that first visit, speaking from the Sage pulpit to an overflowing crowd. “And I submit to you this morning that an individual hasn't begun to live unless he can rise above the narrow confines of his individualistic concerns to the broader concerns of all humanity.”

Another alum who attended the Statler breakfast, Harry Edwards '62, had the chance to spend more one-on-one time with King as one of his student escorts. Recalling those interactions more than a half-century later, he says King had a

profound impact on him. “It was everything about him—his entire demeanor, his brilliance, his achievements,” says Edwards. “So much so that when he left campus, I revisited my goals and started applying to divinity school.” Though Edwards later chose to study law, King's words still echoed; they spurred him to excel in his career, which included a position as the first African American faculty member at the University of Michigan Law School and a judgeship on the U.S. Court of

‘I submit to you this morning,’ King told the Sage Chapel crowd, ‘that an individual hasn't begun to live unless he can rise above the narrow confines of his individualistic concerns to the broader concerns of all humanity.’

Appeals in Washington, D.C. King, Edwards says, “gave great strength to lots of black people to understand our place in this country and this world. He caused a lot of us to step up our game—because the more of us that succeed, the more there will be to help open doors for those behind them.”

On the Sage Chapel wall, above the pulpit where King spoke so many decades ago, hangs a plaque commemorating his appearance—as well as one by his father, Martin Luther King Sr., who delivered a sermon there two decades later. The plaque was installed in 2007, in an event that included a speech by Dorothy Cotton, a fellow civil rights leader who worked with King for more than a decade. “Many people associate the civil rights movement with great suffering and sadness,” Cotton said. “However, from another perspective, that earth-changing movement gave millions a new reason to live.” ■

—Alexandra Bond '12



CLOSE-KNIT

*Shop our selection of
warm sweaters & hoods
by Brüzer.*

TheCornellStore®

STORE.CORNELL.EDU

or call toll-free 844.688.7620

Let's go to look for America!



Families are welcome on our bucket list tours of North America brought to you in partnership with Orbridge.

NATIONAL PARKS OF THE OLD WEST, JULY 19 – 28, 2018

Badlands, Custer, Yellowstone, Grand Teton & more!

CANADIAN ROCKIES, AUGUST 2 – 8, 2018

Lake Louise, Jasper, Maligne Lake, Banff & more!

SOUTHWEST NATIONAL PARKS, OCTOBER 22 – 31, 2018

Grand Canyon, Monument Valley, Arches, Canyonlands, Bryce Canyon, Zion & more!

Call 866-639-0079
for details or check out
our website to see the
brochures for these
and other 2018 tours!

alumni.cornell.edu/travel/