

A Technical Reference Guide for Dairy-Derived Biogas Production, Treatment and Utilization

January 7, 2019

Updated: July 29, 2020

By:

¹Tim Shelford, ¹Curt Gooch, ²Abhinav Choudhury, and ²Stephanie Lansing

¹Cornell PRO-DAIRY Dairy Environmental Systems Program

²University of Maryland Department of Environmental Science and Technology

Note: *A Technical Reference Guide for Dairy-Derived Biogas Production, Treatment and Utilization* was a deliverable under NE SARE Project Number – LNE15-341. The document and its contents were based on the best available information available at the time of publication. The authors wish to thank Maggie Hines (University of Maryland), Gary Felton (University of Maryland), Peter Wright (Cornell), Jenny Pronto (Cornell), Allison Costa (USEPA), and Dan McFarland (Penn State Extension) for their reviews of the document and helpful comments.

The Guide is intended to provide farmers with helpful information on:

1. Factors affecting biogas production and composition
2. Treatment capabilities for different types of biogas scrubbing systems
3. Various options for biogas utilization

Table of Contents

Definitions and Abbreviations	5
1 Introduction.....	6
1.1 Document organization	6
1.2 Target audience	6
1.3 Limitations	6
1.4 Additional resources.....	7
2 Biogas Production.....	8
2.1 Anaerobic digestion basics.....	8
2.1.1 Waste characteristics.....	8
2.1.2 Digester microbiology and biochemistry.....	8
2.1.3 Biogas production and composition.....	12
2.1.4 Digester types.....	13
2.1.5 Temperature	15
2.1.6 Acidity vs. alkalinity (pH)	17
2.1.7 Retention time.....	19
2.1.8 Agitation	20
2.1.9 Loading.....	20
2.2 Estimating biogas production.....	21
2.2.1 Normalized data	22
2.2.2 Volatile solids and stoichiometry.....	24
2.2.3 Biochemical analysis	25
2.2.4 Long-term reactor trials	26
2.3 Biogas energy content	26
2.4 Influences of dairy farm practices on the composition of biogas source material.....	28
2.4.1 Cow feed → Sulfur compounds.....	29
2.4.2 Water → Sulfur compounds	30
2.5 Anaerobic digestion biogas system.....	30
2.6 Biogas testing and monitoring.....	33
2.6.1 Biogas field testing	33
2.6.2 Biogas lab testing.....	37
2.7 Biogas concerns.....	37
2.7.1 Biogas safety.....	38
2.7.2 Sensors for Personal Safety Monitoring	38

2.7.3	Biogas corrosion	40
3	Biogas Clean-up.....	42
3.1	Introduction	42
3.2	Hydrogen sulfide removal.....	43
3.2.1	Physical/chemical	43
3.2.2	Microbial fixation	49
3.2.3	Digester influent additives	56
3.3	Moisture removal	59
3.3.1	Passive.....	60
3.3.2	Refrigeration	61
3.3.3	Desiccants	62
3.4	Carbon dioxide removal.....	63
3.4.1	Regenerative water wash	63
3.4.2	Regenerative amine wash	64
3.4.3	Pressure swing adsorption.....	65
3.4.4	Membrane separation.....	69
4	Biogas Utilization	71
4.1	Introduction	71
4.2	Combined heat and power.....	71
4.2.1	Reciprocating internal combustion engine.....	71
4.2.2	Microturbine	86
4.3	Boiler.....	87
4.4	Transport fuel	88
5	References.....	90
	Appendix A. Additional Resources	94

Definitions and Abbreviations

AD:	Anaerobic digestion
ATM:	Atmospheric pressure
BG:	Biogas
Btu:	British thermal unit
BTF:	Biological trickling filter
Biogas:	The gaseous production from anaerobic digestion containing primarily CH ₄ , CO ₂ and H ₂ S with other trace contaminant gases
Biomethane:	Methane (CH ₄) derived from biogas as opposed to natural gas
CFC:	ChloroFluoroCarbon
CFM:	Cubic feet per minute (ft ³ /min)
CH ₄ :	Methane
CHP:	Combined heat and power
CNG:	Compressed natural gas
CO ₂ :	Carbon dioxide
EGS:	Engine-generator set
GC:	Gas chromatograph
H ₂ S:	Hydrogen sulfide
HRT:	Hydraulic retention time
LCE:	Lactating cow equivalent
MMBtu:	Million British thermal unit
NH ₃ :	Ammonia
O ₂ :	Oxygen
PPB:	Parts per billion
RNG:	Renewable natural gas
SCFM:	Standard cubic feet per minute (ft ³ /min)
SMY:	Specific methane yield
STP:	Standard temperature and pressure
Tail Gas:	Waste gas from biogas clean up systems
TMR:	Total mixed rations
TS:	Total solids
TVS:	Total volatile solids
VS:	Volatile solids
WV:	Water vapor

1 Introduction

1.1 Document organization

This document is broken down into three major sections: Biogas Production, Biogas Treatment, and Biogas Utilization.

- **Biogas Production:** Provides information with respect to dairy manure-based anaerobic digestion systems, including factors affecting biogas production and composition, biogas testing and biogas safety.
- **Biogas Treatment:** Covers the options available to remove contaminants (compounds other than CH₄) from raw biogas streams.
- **Biogas Utilization:** Describes the most common usages of biogas both on- and off-farm (in the case of pipeline quality biogas).

1.2 Target audience

This document is primarily intended to be used by dairy farmers and their advisors in developing/operating on-farm biogas production systems, though other producers/users of biogas may also find the material relevant. By providing a comprehensive yet simple background of dairy biogas production, clean-up options, and usage in a single document the authors hope to foster the development of new dairy anaerobic digestion systems and/or the improvement of existing systems.

The final section of this document, the biogas cleanup system selection, is aimed at providing a quick summary of the available scrubbing technologies and the requirements (farm size, cost, etc.) usually required in order to provide the user with a means to identify possible systems based on their existing or proposed anaerobic digestion project characteristics.

1.3 Limitations

Throughout this document, tables of expected values for biogas yields, removal efficiencies, and other data necessary to plan biogas generation and treatment systems are provided. These values should be used with caution, as performance can vary significantly based on factors such as climate, management experience with equipment, maintenance budget, system design, etc.

An example of variability that exists from farm-to-farm is illustrated in Figure 1 where the average concentration of carbon dioxide (CO₂) and methane (CH₄) (dry biogas basis) from eight dairy manure based anaerobic digesters (AD) in New York State (NYS).

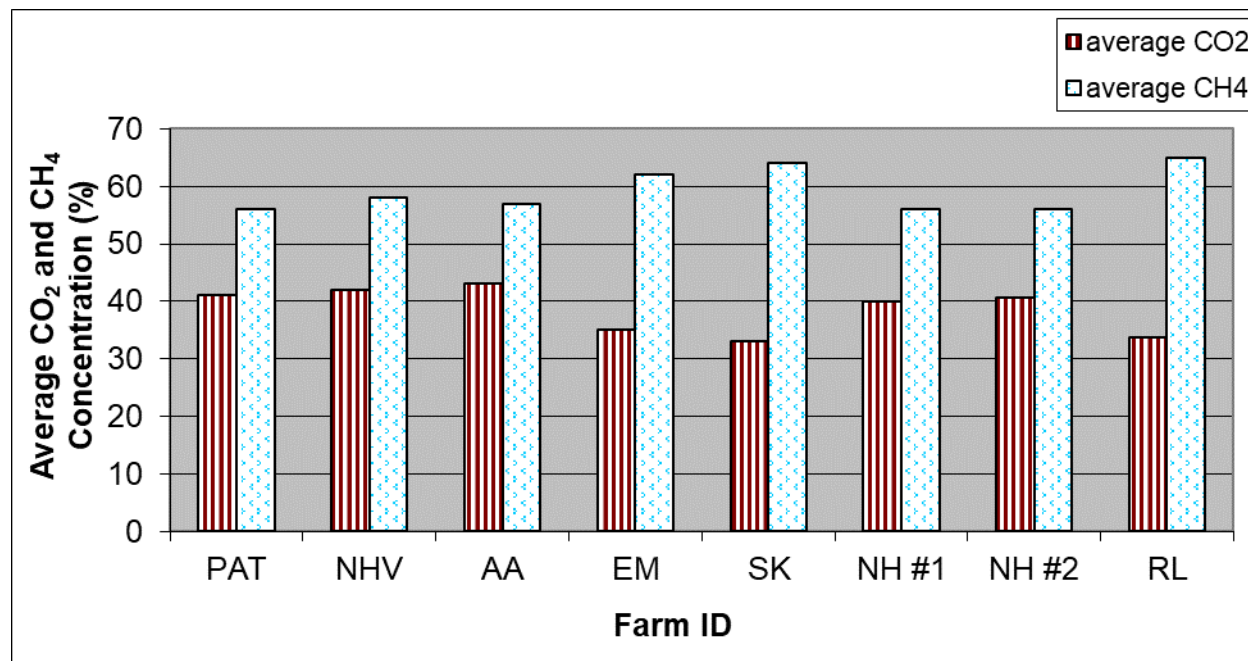

Figure 1. Measured average carbon dioxide and methane concentrations at several NYS farm-based AD facilities. For the farms on the x-axis listed left to right, the values are based on the following numbers of samples: 22, 22, 25, 18, 21, 19, 19, and 15. Source: Gooch et al., 2011.

For detailed planning and system sizing, farm data obtained from similar full-scale systems is preferable (though often difficult to find, particularly for new systems).

1.4 Additional resources

Further background material on dairy anaerobic digestion, review of relevant case studies, fact sheets, tech notes, and research reports are available on the Dairy Environmental Systems program website (www.manuremanagement.cornell.edu). The major themes for which information is available is provided in Appendix A. Also, several factsheets and other relevant materials are provided at the following website: <https://enst.umd.edu/about/opportunities-and-challenges-anaerobic-digestion>.

2 Biogas Production

2.1 Anaerobic digestion basics

Biogas can intentionally be produced on dairy farms from manure and other on-farm or imported organic products using AD, where organic material is digested or broken down in an environment lacking oxygen. The digestion process that starts in the gut of the cow is continued to more thoroughly break down the organic matter in the food the cow consumes within a digestion vessel. The anaerobic microbes that break down organic matter produce CH_4 , CO_2 , and trace gases, including hydrogen sulfide (H_2S).

2.1.1 Waste characteristics

The average U.S. Holstein dairy cow produces 150 pounds of manure (urine + feces) daily. As excreted, this manure contains about 20 pounds of solid material: 17 pounds of solids that can break down (volatile solids, VS), 3 pounds of solids that cannot be broken down (fixed solids, FS) and nutrients; nitrogen (1 lb.), phosphorus (0.18 lbs.), and potassium (0.2 lbs.) (ASABE, 2006). Excreted manure characteristics are changed in-barn (e.g. soiled bedding sprinklers, dumped water troughs, evaporation, method of cleaning barn) and later (e.g. mixing with milking center wastewater, rainwater, feed refusals). Consideration for these items is needed in order to more accurately determine the actual AD influent volume and characteristics.

Imported organic matter contains moisture, solids, and nutrients. The volume and characteristics of organic substrates for co-digestion need to be understood as they affect many items including hydraulic retention time (HRT), biogas production and composition, and overall system management. Overall, from an anaerobic digestion standpoint, the key items of interest are volume (loading rate, as discussed in 2.1.9), biological energy content (VS) (as discussed in 2.1.3), and biodegradability (as discussed in 2.3).

2.1.2 Digester microbiology and biochemistry

Anaerobic digestion is a process in which multiple groups of operative microbes work together in a sequential fashion to convert a portion of the organic matter into biogas. The complex organic material in manure and other biomass sources is broken down by these microorganisms in the

absence of oxygen (anaerobic). The end products are biogas comprised of CH₄, CO₂, water vapor and trace gases; and a stabilized, mostly liquid effluent.

This process occurs naturally in many existing manure storages, especially those that store untreated manure long-term. Unfortunately, in most natural situations the process does not go to completion and many of the intermediate microbiological products are quite odiferous.

Cow manure is composed of urine and feces. Typical composition of cow manure is 12% dry matter (total solids), 10% organic matter (volatile solids), 2% ash (fixed solids), and 88% water. Given 100 lbs of manure, the portion of the manure's total volatile solids (VS) that are microbiologically converted into biogas is about 4 lbs of manure, which constitutes about 35% of the total VS in the raw manure and only 4% of the original 100 lbs of raw manure. When the VS is converted to biogas, the effluent will have less solids and be more consistent making the effluent easier to handle with liquid manure equipment. Studies have shown conversion of VS to biogas can vary for each system. For example, a recent study of a digester with an hydraulic retention time (HRT) of 29 days showed that only 25% of the VS coming into the digester was biological degraded to produce biogas.

The overall process involves three main steps; first, hydrolytic bacteria initiate a process called hydrolysis. These bacteria use extra-cellular enzymes to convert insoluble organic fibrous material into soluble material; however, inorganic solids and hard-to-digest organic material are not converted. The process of the anaerobic digestion of dairy manure is shown in Figure 2.

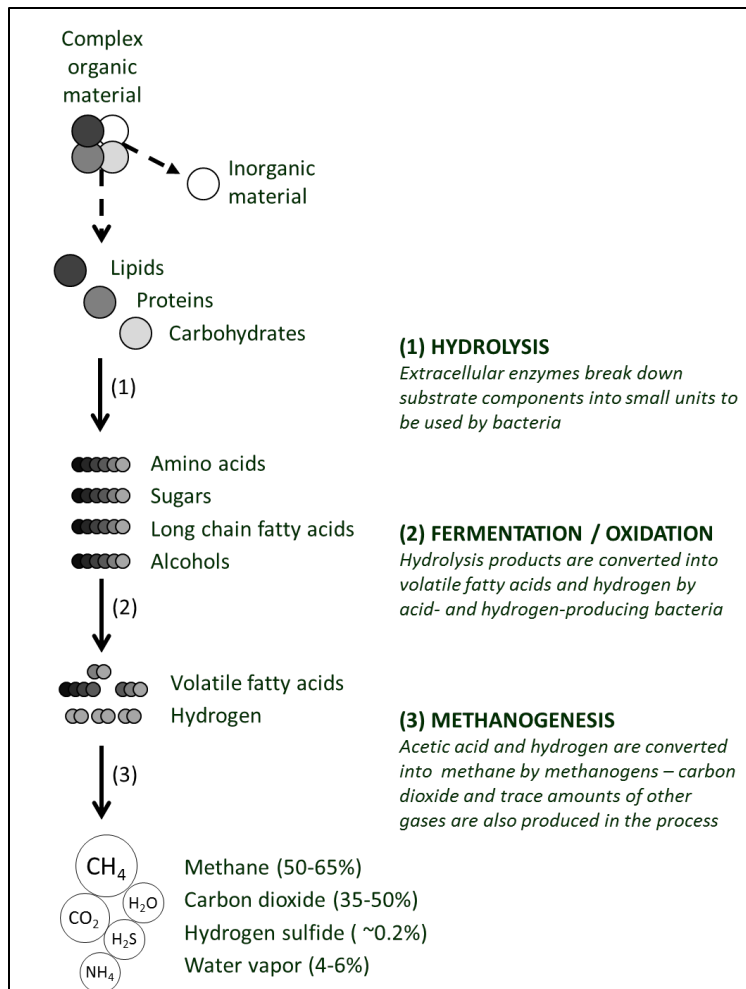

Figure 2. Fundamental steps in the anaerobic digestion of complex substrates (Labatut and Pronto, 2018).

Next, acid forming bacteria convert the soluble carbohydrates, fats, and proteins to short-chained organic acids, also known as volatile fatty acids. The acids produced in step two become the food source for the methanogens, which produce methane gas during the third step.

Of the overall biochemical processing chain, the methanogens are the weakest link. This is because methanogens:

- are the most sensitive to pH (prefer 6 to 8 with optimal at 7)
- are the most sensitive to digester temperature fluctuations
- cannot tolerate oxygen
- need simple organic acids for food
- are the least robust of the operative microbes
- grow slowly compared to the other operative microbes.

Digesters need to be able to retain sufficient populations of methanogens to complete the breakdown of the acids and produce methane. It is very important that an anaerobic digester designer consider the environment within the digester to be sure the pH, temperature, and retention time is appropriate allowing for a sufficient population of methanogens to convert microbial generated acids to biogas.

Various methanogenic species grow in different temperature regimes.

1. Psychrophilic methanogens live/reproduce in the lowest of the temperature ranges, less than 68°F. Methanogens in this range grow slowest and produce the least biogas per unit of time. Covered long-term storages, especially those in northern climates, will be in this range much of the year; supplemental heat is typically not provided in these systems.
2. Mesophilic methanogens live/reproduce in an optimum temperature of about 100°F (the most common operational temperature for digesters in the U.S.). Supplemental heat is needed in this type of system.
3. Thermophilic methanogens live/reproduce in an optimum temperature of about 130°F. A review of European digester systems revealed that the rate of biogas production per unit of time is highest when thermophilic microbes are active. Additional heat is needed, and thermophilic organisms are most sensitive to temperature changes. The higher operating temperature also increases pathogen reduction, and allows for shorter retention times, thus reducing the capital cost of the digester vessel.

Performance of anaerobic digesters is highly dependent on environmental factors. Physical and chemical parameters should be maintained within the optimal ranges to maximize system efficiency and promote process stability. Proper system configuration and a rigorous control of the process parameters are critical to keep environmental variables steady and within the desired range. In addition, periodic monitoring of sensitive parameters such as pH, temperature, volatile fatty acids (VFA), and ammonia, is necessary to ensure optimal system performance.

The VFA concentration can be used as a process performance indicator. The VFAs in the digester are integral to biogas formation, but too high of a concentration can inhibit the digestion process, which can lead to system failure. VFAs encompass a group of six acids, i.e., acetic, propionic, butyric, valeric, caproic, and enanthic, with acetic acid being predominant in most digestion systems. In a correctly designed and well operated digester, the concentration of total VFA is typically below 500 mg/L as acetic acid. However, if the digester is undersized for the organic load this concentration can be higher. At VFA concentrations over 1,500 – 2,000 mg/L, biogas production might be limited by inhibition. However, rather than a specific concentration, a sudden and steady increase of VFAs in the effluent can be a sign of a digester upset. Thus, for high organic load systems (many of those associated with co-digestion of energy intense substrates), it is essential to monitor VFAs periodically in order to detect problems and make the necessary operational changes before digester failure occurs.

2.1.3 Biogas production and composition

Natural gas is made up of nearly 100% CH₄. Biogas is similar to natural gas in that the majority (55-68%) of the gas is composed of CH₄, the actual source of energy. However, biogas also contains a significant portion of CO₂ (32-45%) (See Figure 1), water vapor (WV: 3-4%), ammonia (NH₃: 0 to 300 ppm), and very low but problematic quantities of H₂S (1,500 – 8,000 ppm).

Use of Fyrite[®] gas analyzers and colorimetric gas detector tubes have shown an average of 40% concentration of CO₂ (Gooch et al., 2011) for eight farms studied. These readings were for dry biogas. Ludington and Weeks (2008) found that when the biogas is at 76°F it contains 3% WV. More moisture mass is contained in saturated biogas as the biogas temperature increases. For example, saturated biogas at 80°F contains 3.4% WV.

Biogas quality depends on CH₄ content, H₂S content, WV content, and possible presence of contaminants from the gas handling equipment. The concentration of CH₄ in the biogas can vary due to a variety of conditions, some of which may be difficult to determine. Specifically, temperature, influent feed rate, cattle feed ration changes, and non-manure substances introduced with the digester influent can affect the productivity of the microorganisms within the digester, and thus, the concentration of CH₄.

Biogas is saturated with WV when it leaves the digester, and this WV should be removed through condensation prior to biogas use. In addition, H₂S is a highly corrosive and hazardous gas (see section 2.7.1 Biogas safety), which when combined with WV can corrode equipment (e.g. metal piping, burner units and heat exchangers in boilers, furnaces, and water heaters) and also accelerate the development of acidic conditions in engine oil. H₂S should be removed prior to biogas use.

Additionally, oxygen can be a possible gas contaminant depending on the biogas end use. Oxygen can enter the biogas stream when biogas is treated for H₂S through use of a biological trickling filter (BTF) when ambient air is introduced as part of the treatment process.

While not necessarily considered a biogas quality issue, a related condition that affects biogas quality and biogas piping is contamination from digester foaming events. Foam is a large amount of gas (~ 95%), with a small amount of liquid and particulate matter that can block gas pipelines, if unchecked, while contaminating the biogas. Foaming events can happen after rapid changes in feed substrate or feeding timing. To reduce foaming, it is suggested to slowly add new feedstocks into the digester over time and reduce downtimes in the feeding regime to keep the substrate inputs consistent.

Potential, but very unlikely, additional contaminants in dairy manure-derived biogas, include the following contaminants typically found in other sources of biogas (i.e., landfill-generated biogas):

- Siloxanes
- CFCs
- Nitrogen gas (N₂)

Co-digestion operations that have imported off-farm substrates have a higher likelihood of encountering one or more of these contaminants.

2.1.4 Digester types

The first anaerobic digesters constructed on dairy farms in the U.S. were plug-flow digesters, and subsequently many similar systems have been built and are operational in the Northeast. The

primary reason for their historically wide-span adoption is that plug-flow digesters are low in equipment and operating costs (not necessarily overall costs) relative to mixed digesters. Plug-flow digesters are generally below-grade vessels in which manure additions theoretically flow as a “plug” from the digester inlet to the outlet. Digested manure generally exits the digester at the end opposite the inlet at a point of time in the future that equals the digester’s HRT. An advantage of plug-flow digesters is that they do not have the mechanical complexity associated with mixed digesters, but a disadvantage is they have limited use due to the recommendation of a higher solids content (8 – 14 % TS) in plug-flow system to reduce settling within the digester. Reduction of the HRT from the accumulation of settled and floating solids occurs with the addition of other substrates that contain more moisture than dairy manure.

Complete-mixed digesters periodically or continuously mix dairy manure and potentially other feedstock(s) by mechanical means. One advantage of a mixed digester is the ability to handle wastes with higher or lower moisture contents (compared to plug-flow units), including imported food wastes. When manure is too liquid, separation of solid and liquid fractions is more likely to occur. Periodic mixing maintains homogeneity of digester contents and minimizes significant solids accumulation.

One disadvantage of mixed digestion is that the mixing components add mechanical complexity and electrical parasitic load (standby power consumption when units are switched off), thus, increasing total operational costs. In addition, AD influent is mixed with contents already undergoing digestion, and as a result, mixed digester effluent contains AD contents that have been in the tank for various lengths of time. Therefore, there is the possibility that undigested manure may exit the digester prematurely and that well-digested manure may remain in-vessel in excess of the design HRT.

Manure management systems that utilize scraped manure generally employ plug-flow or mixed digesters. When scraped systems are used and milking center wastewater is combined with the manure, the total solids can decrease to 3-11%. In this solids content range, a mixed digester is appropriate. When total solids are very low, <3%, as seen in flush systems, a covered lagoon or fixed film digester are valid options.

Covered lagoon digesters are basically covered manure storage lagoons that capture the methane that is produced from the storage ponds. A covered lagoon digester has lower capital and operational costs, but the unheated nature of the digester leads to a seasonal variation in biogas production, with lower to no biogas production in the winter months, depending on geographic location.

Fixed film digesters are packed with media that support the attachment and growth of the essential microorganisms required for anaerobic digestion. Since a high solids content can obstruct the flow of manure through the media, fixed film digesters are the most efficient with flushed dairy manure and solid separation before digestion.

For organic waste co-digested with manure, a mixed system is recommended (Wilkie, 2005). Systems where water is added to dilute the waste often require a larger digester and mixing to keep solids from settling. Table 1 shows the recommended digester types based on existing manure collection system in use at the farm, as well as the solids concentration.

Table 1. Application of digester types based on bedding and manure collection system, and influent total solid concentration.

Manure System	% Total Solids (TS)	Recommended Digester Type
Flush	<3	Covered Lagoon Fixed Film
Scrape + Milking Center Wastewater	3 - 11	Complete Mix
Scrape – Manure + Soiled Organic Bedding	>11	Plug Flow
Organic co-digestion	Variable	Mixed system – complete mixed or plug-flow with mixing
Sand Laden Dairy Manure	3 - 5	Complete Mix (Pre-treatment to remove bedding sand required)

2.1.5 Temperature

Methane production rate is dependent on target digester operating temperature and temperature consistency. Anaerobic digesters are generally operated in the mesophilic (95-104°F) or

thermophilic temperature range (122-140°F) (Gerardi, 2003). These temperature ranges are optimal for two different categories of methane-forming bacteria.

Temperature changes affect enzymatic activities and microbial reaction rates and therefore, greatly affect biological activities within the digester in addition to greater pathogen destruction (Gerardi, 2003). Higher temperatures result in greater enzymatic activity and lower temperatures decrease enzymatic activity. In the thermophilic temperature range, reactions occur faster because of the increased enzymatic activity. This increased reaction rate increases gas production compared to mesophilic temperatures (Figure 3). However, thermophilic bacteria have been shown to be more sensitive to environmental changes, such as high organic loading rates, feeding irregularities, and temperature fluctuations (Kim et al., 2006). Shock from sharp increase or decrease in loading rates in thermophilic digestion can lead to decreased microbial activity from the microorganisms responsible for CH₄ production (van Lier, 1996).

Additionally, feed interruptions can lead to slow recovery of biogas production due to accumulation of volatile fatty acids in the digester (Wiegant, 1986). Thermophilic microorganisms are less diverse compared to mesophilic microorganisms, and thus, environmental changes can significantly lower their activity, leading to operational problems within the digester (Labatut et al., 2014). In addition, there is a higher risk of ammonia production during thermophilic digestion that can lead to inhibition of CH₄ production (Al Seadi et al., 2008).

Susceptibility to temperature fluctuations is a primary concern for thermophilic digestion processes. If temperatures within the digester drop below ~ 90°F, CH₄ production rate can slow significantly, even though volatile fatty acids are still being produced. The increased fatty acid concentrations can affect the pH of the digester if the methane-forming bacteria cannot utilize the acids at an appropriate rate.

Many problems observed in anaerobic digesters come from issues associated with digester heating and temperature changes. Temperature changes in digesters affect most biological activity, especially methane-forming bacteria.

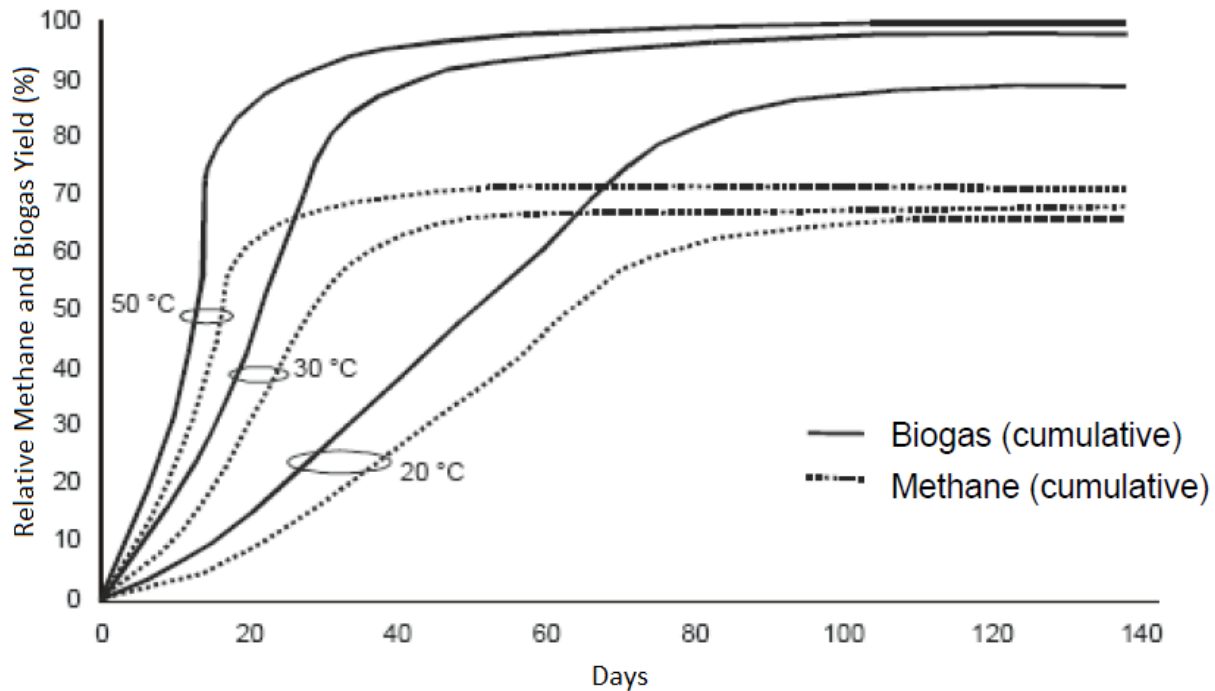

Figure 3. Relative biogas yield and rates at psychrophilic, mesophilic, and thermophilic temperatures (Al Seadi, 2008).

2.1.6 Acidity vs. alkalinity (pH)

Digester pH should be maintained between 6.8 and 7.2 since this is optimal for the activity of methane-forming bacteria (Khanal, 2011). Manure-based digesters that are not heavily loaded with rapidly biodegradable substrates (e.g. fats, oils, greases) naturally stay within this range due to the high buffering capacity of manure. Digesters without sufficient buffering capacity may need to have a caustic compound added (Table 2) to adjust the alkalinity and maintain pH, but this is rarely the case with manure-based digesters. Alkalinity in this pH range can help to buffer the digester from the acid formed during the digestion process. Alkalinity is important because it prevents rapid changes in pH and helps to maintain the pH in the optimum range for enzymatic activity of methane-forming bacteria.

Table 2. List of candidate chemicals used for maintaining digester pH (Gerardi, 2003).

Chemical	Formula	pH change
Sodium bicarbonate	NaHCO ₃	Slow
Potassium bicarbonate	KHCO ₃	Slow
Sodium carbonate (soda ash)	Na ₂ CO ₃	Slow
Potassium carbonate	K ₂ CO ₃	Slow
Calcium carbonate (lime)	CaCO ₃	Fast
Calcium hydroxide (slaked lime)	Ca(OH) ₂	Fast
Anhydrous ammonia (gas)	NH ₃	Slow
Sodium nitrate	NaNO ₃	Slow

Care is needed if lime (CaCO₃) is mixed with digester influent to increase digester pH. Once the pH is above 6.4, lime should no longer be used, because above this point, it may increase the pH too rapidly and does not add alkalinity to help with buffering.

Lime initially reacts with dissolved CO₂ in the digestate but if lime is added too quickly and CO₂ in the sludge is depleted, CO₂ from the biogas will enter into the liquid, which can create a vacuum under the digester dome potentially causing the cover to collapse. Bicarbonate or carbonate salts (NaHCO₃ or KHCO₃) should be used to increase the pH between 6.4 and 6.8 and help replenish alkalinity (Gerardi, 2003; Khanal 2011). Sodium bicarbonate is preferred because it is non-toxic, readily soluble, and safer, as it does not lead to sudden CO₂ depletion but could be more expensive depending on the amount needed, when compared to lime addition.

When incorporating sodium bicarbonate (NaHCO₃) or sodium carbonate (Na₂CO₃) to a digester, CO₂ gas can be released, while incorporating sodium nitrate (NaNO₃) releases N₂ and N₂O gases. Anhydrous ammonia can help dissolve foam with pH adjustment but can be toxic if the pH increases above 8, since the dissolved ammonia gets converted to ammonia gas. The release of these gases can cause foaming if the chemicals are added too quickly. pH should always be adjusted carefully and slowly to avoid foaming or cover collapse.

Cost benefit analyses of pH modifying chemicals vary, and these chemicals should be used only when a digester is going “sour.” Manure has a high pH buffering capacity, and therefore, the pH does not normally decrease sharply in manure-based digesters unless there is sudden change in the feedstock or feeding regime. Care should be taken before adding these chemicals for pH

adjustment. The amount of chemicals required (and thus, cost analysis), can be difficult to estimate, as it depends on the characteristics of the digestate.

2.1.7 Retention time

HRT is a measure of the total time (days) which a volume of organic substrate resides in a digester vessel, i.e., the digestion time. HRT affects the rate and extent of methane production. On average, bacteria in a manure-based anaerobic digester breaks down organic matter and converts it into biogas with the target HRT varying based on influent composition and operating temperature. The generally recommended HRT for manure-based digesters is 15 to 21 days. Higher retention times are possible and used in Europe with maize silage digestion, but higher HRTs will increase digester capital costs due to increased vessel size. Normally for manure-only or co-digestion systems that have readily biodegradable solids (e.g. pre- and/or post-consumer food wastes), a 20-day retention time will be sufficient, but it ultimately depends on the substrates being digested and the amount of residual methane in the uncovered lagoons deemed acceptable.

Higher temperatures result in an increased rate of methane production thus requiring a shorter HRT for the same biogas yield per unit of solids digested. At higher temperatures (thermophilic vs. mesophilic), not only is the digestion reaction quicker, also operative microbes' regeneration rate is increased.

Anaerobic bacteria are unable to efficiently digest high lignin-content material (e.g. sawdust/wood shavings used for stall bedding, corn stover) in short periods of time. For a significant and useable quantity of biogas to be produced from these products, a longer retention time (100+ days) would be required. Additionally, dirt and grit found on barn floors are inert and thus do not add to biogas production and may build up within the digester vessel. Added dilution water with minimal VS also decreases the HRT with a corresponding decrease in biogas production. Their inclusion should be avoided when possible. Inert materials in digester influent take up volume, reducing biogas production due to shortened HRT.

2.1.8 Agitation

Mixing enhances the digestion process by distributing bacteria, substrate, and nutrients throughout the digester. Acetate-forming bacteria and methane-forming bacteria need to be in contact with substrates that they are digesting in order for metabolic activities to occur. Mixing helps to ensure this contact between the bacteria and substrate to increase the efficiency of digestion.

Additionally, settling and accumulation of insoluble starches, grit, and solids is minimized with mixing, because these materials are kept suspended with less opportunity to settle and thus are more likely to exit in the effluent, avoiding the aforementioned associated decrease in HRT and decrease in biogas production.

Overall, mixing within the digester vessel accomplishes the following:

- eliminating or reducing foam buildup
- eliminating or reducing areas of uneven temperature
- maintaining digestate chemical and physical uniformity throughout
- rapid dispersion of metabolic wastes (products) produced during substrate digestion
- rapid dispersion of any toxic materials entering the tank (minimizing toxicity)
- reduction of sedimentation of inert/non-digestible solids.

High mixing intensity increases the parasitic load, which decreases the energy efficiency of the system. Extremely high mixing intensity has a negative effect on the floc formation, which affects the synergistic interaction between the different types of microorganisms and it can lead to a decrease in the methane yield (Hoffmann et al., 2008).

2.1.9 Loading

The loading rate is the amount of volatile solids (digestible organic material in feedstock) added to the digester per unit volume of the digester, and is related to HRT. Generally, the recommended loading rate is $\frac{1}{HRT}$ of the digester treatment volume should be added daily. For example, if the digester HRT is 15 days, then one-fifteenth the total digester treatment volume would be added daily. Loading rate is also influenced by the VS concentration in the feedstock. A sudden large increase in the VS concentration is not recommended. If a significant amount of VS-rich organics are added (compared to the average amount of daily VS), such as solid food waste or grease waste

that significantly alter the VS composition of the feed input, this new VS input needs to be added gradually over several days or weeks to let the bacteria within the digester acclimate. Similarly, a gradual decrease in VS loading is recommended if changing to a more dilute feedstock.

When the HRT drops too low, the digester could experience hydraulic overload resulting in insufficient time for methane-forming bacteria to reproduce and/or they are washed out of the digester, which, in either case, compromises methane production. Anaerobic bacteria have a duplication rate of 10 days on average and a HRT lower than 10 days may lead to a gradual decline in the bacteria population (Al Seadi et al., 2008).

Additionally, during hydraulic overload, alkalinity can be washed out of the digester. This reduces the buffering capacity of the digester and, since acids are still being produced, the pH can drop significantly and cause the digester to go “sour”. Hydraulic overload can occur through:

- sudden increase in the loading volume of the feedstock
- waste input beyond the treatment capacity of the digester
- reduction in digester volume due to excessive foaming and build-up of non-biologically digestible solids.

Generally, manure-based digestion systems are resistant to alkalinity washout if the AD is constantly being fed, because of manure’s high alkalinity.

2.2 Estimating biogas production

For new anaerobic digester systems, it is important to estimate raw biogas quantity and quality as accurately as possible so the biogas clean-up and utilization systems can be sized efficiently. Production of biogas is dependent on a number of factors, but primarily upon temperature, HRT and the biochemical energy potential of the influent (i.e. how much energy is in the substrate(s)). Co-digestion systems with food waste added have the ability to produce at least 2-3 times (or more) the biogas of manure-only systems (Labatut et al., 2011). Estimates for biogas production can be made by multiple methods, including:

- normalized data collected from similar digesters
- relationship between influent VS mass and stoichiometry

- biochemical analysis of influent, and
- long-term reactor trials.

Using biogas production data from any of these methods, the Specific Methane Yield (SMY) is determined, which is the total volume of methane produced over the digestion period per amount (mass) of substrate initially added. Then the SMY is applied to a mass of influent to estimate overall biogas/methane yield.

2.2.1 Normalized data

Data collected from farms with similar digester operating parameters can be normalized on a per LCE basis for use in estimating biogas production. A range of 60-100 ft³ biogas/LCE per day can be expected for manure-only influent (Moody et al., 2011). Results from long-term monitoring of manure-only AD systems found biogas production averaged 79 ft³ per LCE [70 ft³ at STP] on six farms over a period of 12 months (Gooch et al., 2011).

The addition of organic materials to the digester can greatly increase the yield of biogas. Daily biogas production for increasing dairy herd size coupled with co-digestion of cheese whey or fats, oils and grease (FOG) is shown in Table 3. Values for Table 3 are based on a biogas production of 79 ft³/LCE-day for raw manure, and then adjusted for each co-digestate substrate addition based on the biomethane yields of Figure 4, and the percentage of substrate added (10 or 25%).

Table 3. Estimated biogas production in CF/day from various dairy herd sizes and two co-digestion materials: whey and FOG (fats, oils and grease).

Farm size (LCE¹)	Raw manure	10% Whey²	25% Whey²	10% FOG²	25% FOG²
100	7,900	8,700	9,900	12,900	14,600
250	19,750	21,700	24,700	32,000	36,600
500	39,500	43,500	49,400	64,400	73,100
1,000	79,000	86,900	98,800	128,700	146,300
1,500	118,500	130,400	148,100	193,100	219,400
2,000	158,000	173,800	197,500	257,500	292,600
2,500	197,500	217,200	246,900	321,900	365,700
3,000	237,000	260,700	296,200	386,200	438,900
4,000	316,000	347,600	395,000	515,000	585,200
5,000	395,000	434,500	493,700	643,700	731,500

¹Lactating cow equivalent

²Percentage of co-digestion materials added on a volatile solids basis

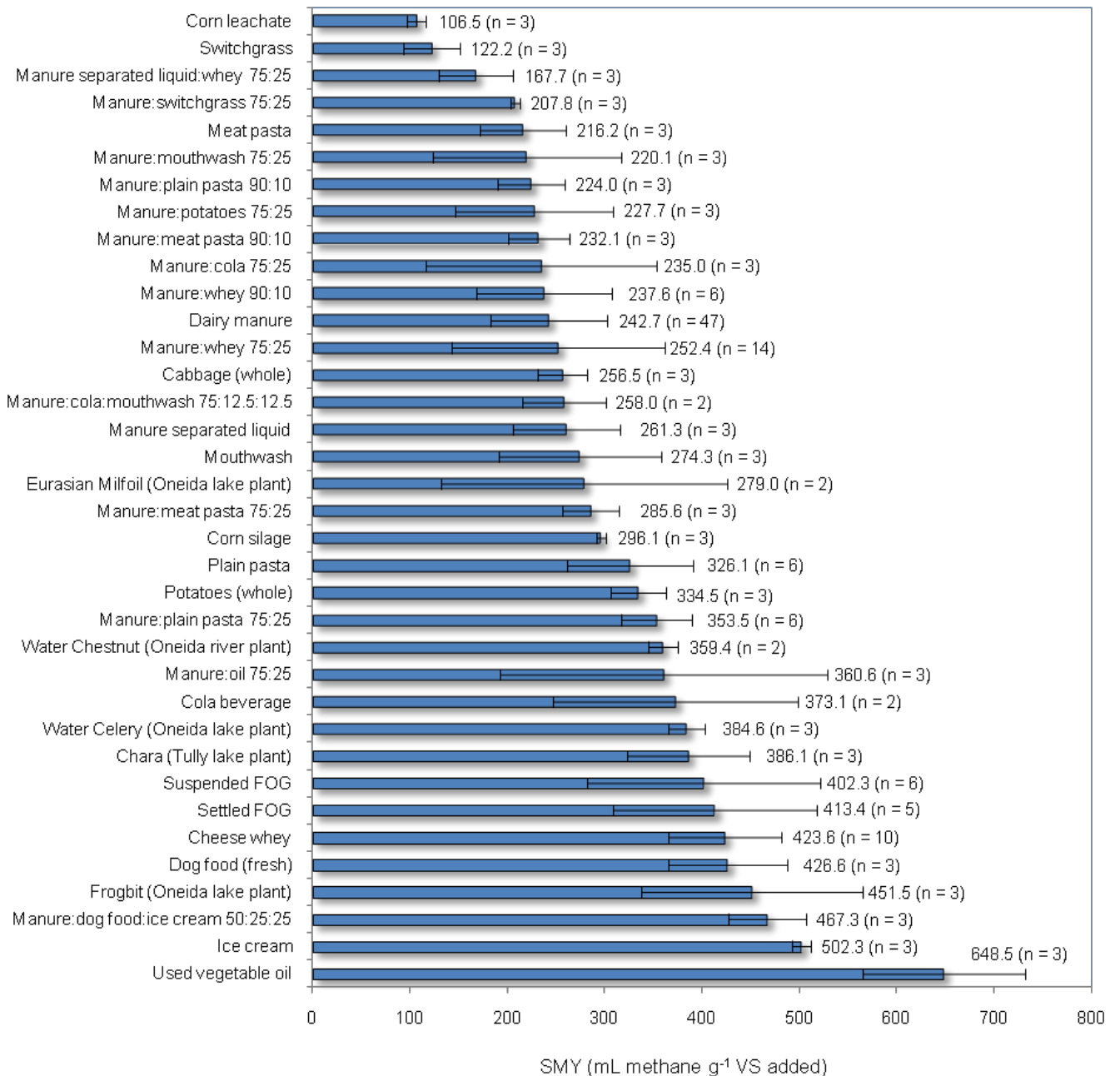

Figure 4. Laboratory-determined specific methane yields (SMY) of 30 mono- and co-digestion substrates. The value outside the bars is the average biomethane potential, with the number of replicates (n) shown in parenthesis. The error bars represent the standard deviation of the SMY for each substrate. Source: Labatut et al., 2011

2.2.2 Volatile solids and stoichiometry

Biogas production for an existing or proposed project can be estimated by measuring the VS content in the influent and applying a known relationship of VS destruction and biogas production. Biogas production potential can be determined by using stoichiometry (based on conservation of

mass throughout a process like conversion of organic matter to biogas). In order to do this, an estimate of the mass of the biologically degradable influent VS is made. Jewell (2007) indicated that an appropriate estimation of CH₄ production is to use a value of 0.5 L CH₄/gram (8 ft³ CH₄/lb) of VS degraded. If the biogas is 60% CH₄, this translates to 12 ft³ biogas (dry)/lb of TVS degraded. The Intergovernmental Panel on Climate Change (IPCC) value for B₀ is 0.24 m³ CH₄/kg VS (B₀ is the maximum amount of methane that can be produced from manure), which assuming that half the VS is consumed, equates to 3.85 ft³ CH₄/lb VS (IPCC, 2006). However, some field experience shows this value to be higher. For municipal wastewater treatment, the EPA *Process Design Manual on Sludge Treatment Disposal* states a range of 12 to 17 ft³ biogas/lb VS degraded (assuming 50% methane concentration, this puts the figure at 6-8 ft³ CH₄/lb VS consumed) (US EPA, 1979). In an extensive study conducted by Moody et al. (2011), it was shown that dairy manure had a methane potential of 3.8 – 4.2 ft³ CH₄/lb total VS. If it is assumed that half the VS are consumed during 40 days, and that the biogas contained 60% CH₄, this indicates the biogas yield for dairy manure would be 6.3 – 7 ft³ biogas/lb VS.

2.2.3 Biochemical analysis

Another method to determine the biogas production potential of an organic material is to perform a biological methane potential (BMP) analysis in a laboratory. The materials to be analyzed are inoculated, placed in a sealed vessel, kept at appropriate temperature, and the production and composition of biogas over time are measured and recorded. The test period normally is 30 to 35 days but can be performed longer if needed. From this biogas production data, the SMY is determined; it should be noted that the SMY is the yield of methane (not biogas, which contains other gases in addition to methane), and that the substrate is based on the amount of VS (the degradable material) and not the total amount of material. A summary of the specific SMY of an array of substrates sometimes used in anaerobic digesters is shown in Figure 4 (Labatut et al., 2011). The energy producing potential of any organic waste depends heavily on the characteristic make-up of the waste, including the carbohydrate, lipid, and protein concentrations. As observed, substrates high in lipids and easily degradable carbohydrates (e.g. used cooking oil, ice cream) have the highest methane production potential. On the other hand, lignocellulosic substrates, such as switch grass and similar substrates co-digested with manure have lower biomethane yields.

2.2.4 Long-term reactor trials

Biochemical energy of an influent material is most accurately evaluated by conducting long-term bench-top reactor tests (Angenent, 2009). While long-term digestion batch tests, such as the BMP, can be used to assess the extent of biodegradability of substrates and ultimate biomethane yields, reactor trials, using semi- or continuous-flows, are used to evaluate performance and stability of AD, where microbial populations are acclimated for specific substrates and product inhibition can be properly assessed over long-term periods.

Long-term studies (i.e. 1-2 years) conducted in bench-scale, semi- or continuous-flow reactors, are designed to emulate the conditions of commercial-scale digesters and to study their overall performance over time; while short-term (i.e. 1-2 months), batch-mode anaerobic digestion tests, such as the BMP, are primarily intended to determine biomethane yields and biodegradability of substrates. For farm AD applications, the use of long-term studies to determine CH₄ yields is normally not employed, due to high cost and the delay of project implementation.

2.3 Biogas energy content

Pure CH₄ has a low heating value of 896 Btu/ft³ (at standard temperature and pressure: 68°F and 1 atm) (Marks, 1978). Correcting for biogas CH₄ concentration, the low heating value of wet biogas is 546 Btu/ft³. As mentioned, the concentration of CH₄ in biogas can vary due to a variety of reasons, including temperature, influent feed rate, cattle feed ration changes, and non-manure substances introduced with the influent, among others. Methane concentration measured at 12 farms in NYS ranged from 55 to 65% for a low heating value of 462 to 546 Btu/ft³ at 1 atmosphere and 80°F (Ludington and Weeks, 2008). Table 4 provides an estimate of the range of energy contained in biogas as a function of farm size and CH₄ concentration.

Table 4. Estimated daily energy production from AD biogas at various dairy herd sizes based on LCE, AD influent composition, and biogas methane concentration (low heating value of 462 to 546 Btu/ft³).

Farm size (LCE ¹)	AD influent	Biogas production (CF/day)	Biogas energy (MMBtu/day)		
			55% CH ₄	60% CH ₄	65% CH ₄
100	Manure only	7,900	4	4	4
100	+10% Whey	8,690	4	4	5
100	+10% FOG	12,874	6	7	7
250	Manure only	19,750	9	10	11
250	+10% Whey	21,725	10	11	12
250	+10% FOG	32,185	15	16	18
500	Manure only	39,500	18	20	22
500	+10% Whey	43,450	20	22	24
500	+10% FOG	64,370	30	32	35
1,000	Manure only	79,000	37	40	43
1,000	+10% Whey	86,900	40	44	47
1,000	+10% FOG	128,741	60	65	70
1,500	Manure only	118,500	55	60	65
1,500	+10% Whey	130,350	60	66	71
1,500	+10% FOG	193,111	89	97	105
2,000	Manure only	158,000	73	80	86
2,000	+10% Whey	173,800	80	88	95
2,000	+10% FOG	257,481	119	130	141
2,500	Manure only	197,500	91	100	108
2,500	+10% Whey	217,250	100	110	119
2,500	+10% FOG	321,852	149	162	176
3,000	Manure only	237,000	110	119	129
3,000	+10% Whey	260,700	120	131	142
3,000	+10% FOG	386,222	178	195	211
4,000	Manure only	316,000	146	159	173
4,000	+10% Whey	347,600	161	175	190
4,000	+10% FOG	514,963	238	260	281

¹Lactating cow equivalent

Biogas has a lower energy density (i.e. less energy per cubic foot) than other common fuels, as shown in Table 5. The lower energy density makes storage of significant quantities of biogas difficult. For example, 78 gallons of biogas at atmospheric pressure, compressed to 200 psig (typical for liquid propane gas storage) has the same energy content as 1 gallon of diesel fuel, as shown in Figure 5. Because historically it has not been economical to compress and store biogas in most cases, it typically has been used in stationary and continuous use applications.

Table 5. Combustion properties of gaseous fuels.

Fuel	Energy density ^(A) (Btu/ft ³ of fuel)	Octane rating
Propane ^(B)	2,283	104
Methane ^(C)	896	120
Biogas ^(D)	546	N/A

^(A) Low heat value at atmospheric pressure

^(B) Primary component of LP gas

^(C) 68°F, 1 atm, Primary component of natural gas

^(D) 60% methane and 60°F

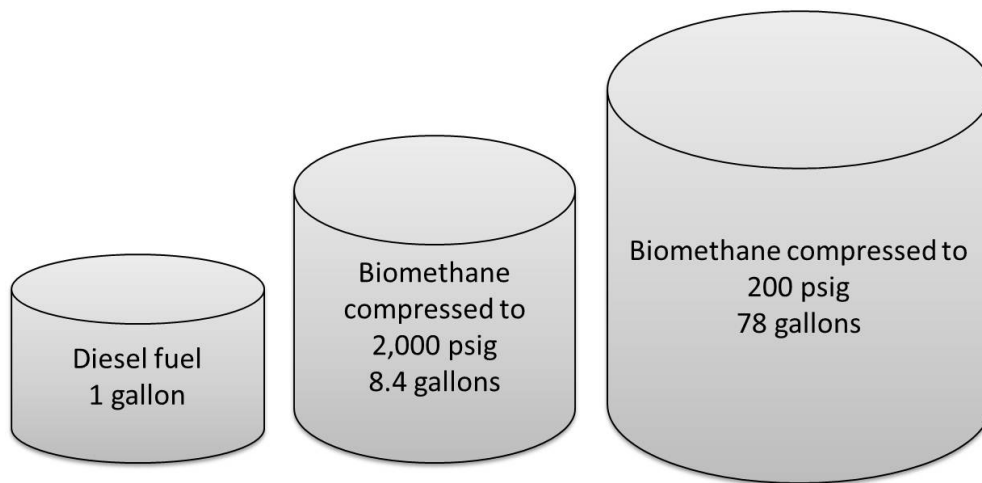

Figure 5. Volume of biogas with energy equivalent to one gallon of diesel fuel.

2.4 Influences of dairy farm practices on the composition of biogas source material

The percentage of H₂S found in biogas can be as high as 8,000 ppm (0.8%) (Bothi, 2007), with influencing factors being levels of sulfur in the cattle feed ration and water supply, and sulfur in non-manure components of the influent stream. A study was performed to determine the origin of sulfur in the H₂S component of biogas. Two graphs, Figure 6 and Figure 7, show where H₂S originates in the case of manure digestion systems as well as co-digesting systems (Ludington and Weeks, 2008).

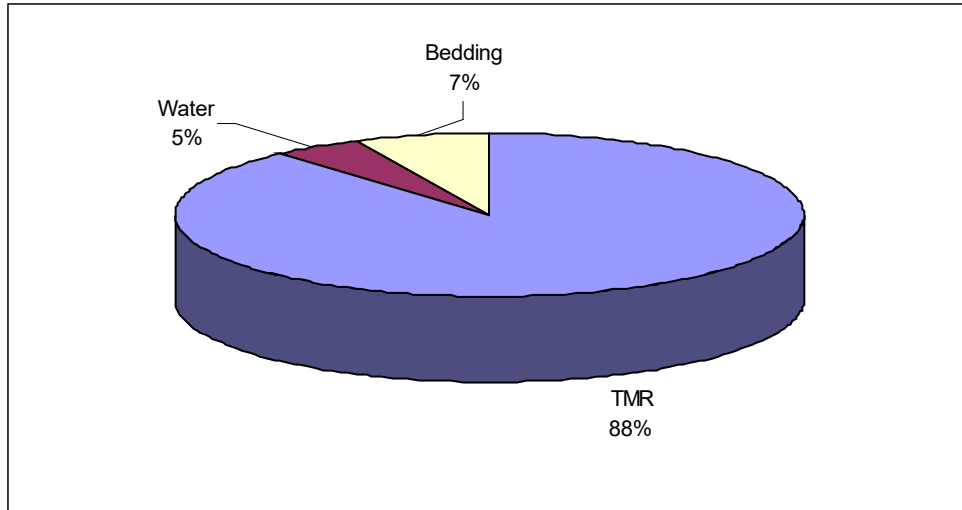

Figure 6. Sources of sulfur for farms not co-digesting, TMR = total mixed ration (Ludington and Weeks, 2008).

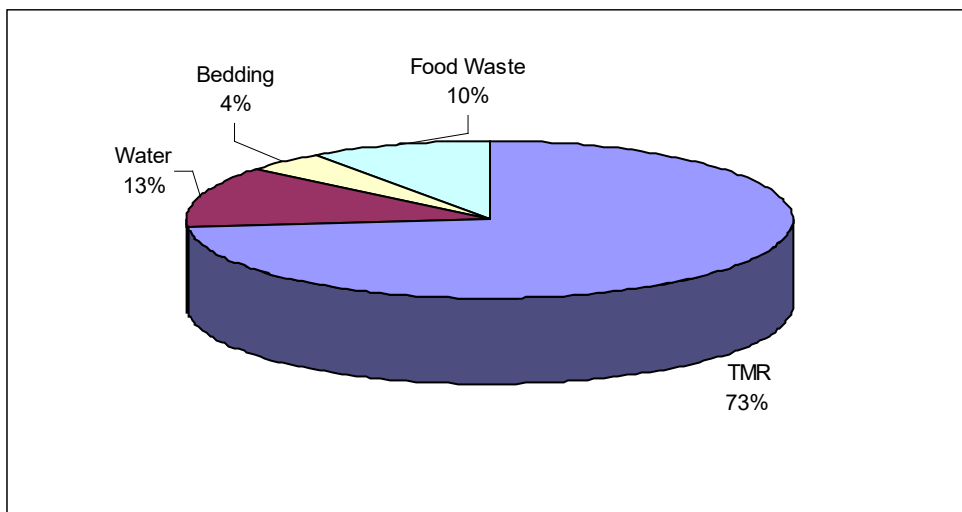

Figure 7. Sources of sulfur for farms co-digesting imported substrates, TMR = total mixed ration (Ludington and Weeks, 2008).

2.4.1 Cow feed → Sulfur compounds

The source with the largest sulfur contribution to H_2S has been shown to be from the total mixed ration (TMR) fed (Ludington and Weeks, 2008). This study showed that the TMR contributed 88% of the sulfur in systems without co-digestion (Figure 6) and 73% of the sulfur in co-digestion systems (Figure 7). A cow diet containing 0.18-0.24% sulfur is required in ruminant digestion to support microbial growth (Crawford, 2007). Common feedstocks such as corn, alfalfa hay, distiller's grain, etc. contain sulfur.

2.4.2 Water → Sulfur compounds

Water, although not a large source of sulfur is the second main source of sulfur in H₂S. Drinking water has a wide variation of sulfur concentrations. In the study by Ludington and Weeks (2008), looking at six farms, the range of sulfur concentration from water ranged from 4.9 to 972 mg SO₄ per liter. The variation in concentration depends on the source (pond; low sulfur vs. stream; high sulfur) and its location (Crawford, 2007 and Ludington, 2008).

2.5 Anaerobic digestion biogas system

Biogas piping and handling is a crucial part of a digester system to eliminate hazards and accidents. Due to the properties of biogas (water saturated, corrosive, presence of toxic gases, etc.), it is important to ensure the correct equipment is used for its handling. The biogas handling system should include:

- **Biogas meter:** A meter designed to withstand the corrosive components and saturated conditions of biogas is essential. Conventional diaphragm meters used in natural gas metering are unacceptable. Meters designed for saturated, corrosive gases should be specified. Some manufacturers of biogas meters include Sage (Model Prime), Thermal Instrument Company (e.g. Model 9500), Fox Thermal (Model FT1).
- **Gas delivery system:** The system should supply biogas to the engine-generator set (EGS) at the pressure required by the manufacturer. It is recommended to accomplish this without mechanically compressing the biogas, however, blowers are almost always needed to increase and to control pressure. Biogas pressure can be checked with a simple manometer, as shown in Figure 8.

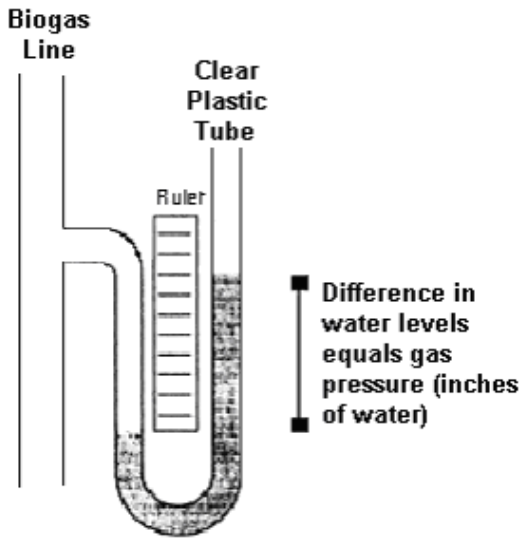

Figure 8. Simple manometer for monitoring gas pressure (Source: Cornell ABEN 458, out of print).

- Pressure relief mechanism:** A maximum gas pressure relief mechanism is needed in order to avoid excess pressure in the biogas system; an example of a water system to achieve this is shown in Figure 9. Maximum gas pressure will be determined by the structural characteristics of the digester. Currently, commercial pressure relief valves are commonly used and provide more ensured protection of the digester structure.
- Condensate Trap:** Water vapor is present in a sufficient quantity to cause condensate trapping in low sections, and subsequent freezing during cold periods. The piping system should be designed so that condensate drains back to the digester to the greatest degree possible. Other preventative measures include installing water traps and condensate drains at low points in the line, insulating exposed sections of pipe, installing heat tape, and routing the pipe with sufficient slope. Adequate pipe sizing is important and should take into account gas flow rates, pipe slope, length of run, and exposure. All biogas lines should be sloped at $\frac{1}{4}$ inch per foot of run. All low points in biogas pipe should include condensate traps. Cooling of 1,000 cubic feet of biogas to 60°F will result in 1-1/2 pints of condensate. The maximum pressure relief valve shown in Figure 9 can serve as a condensate trap.

The pipe for bleeding excess biogas is not necessary if the only purpose is for condensate collection.

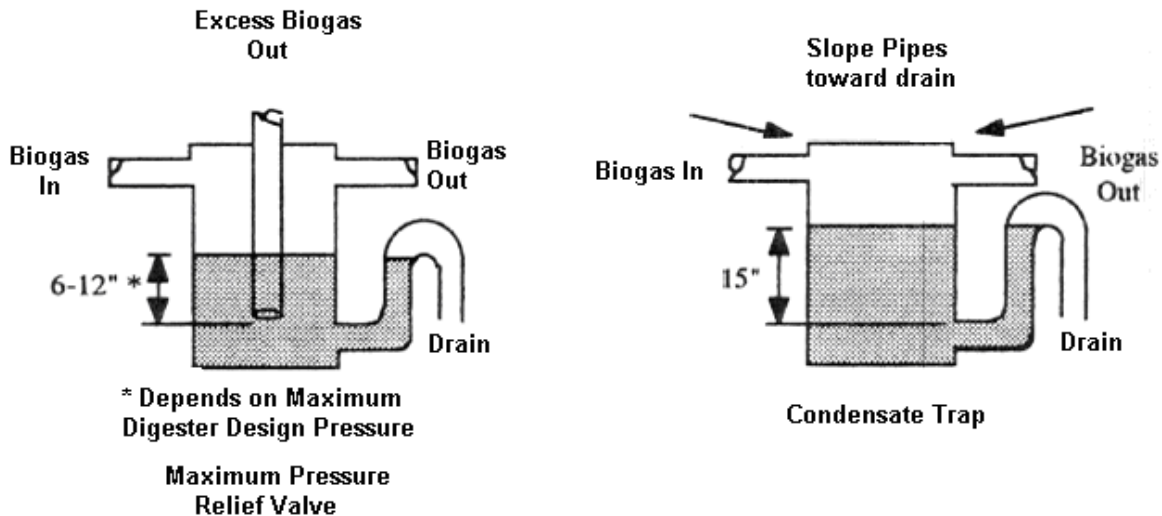

Figure 9. Simple devices for maximum pressure relief valve and condensate traps (Source: Cornell ABEN 458, out of print).

- Non-ferrous pipe:** The potential for introduced contaminants will vary with system design and material composition of biogas handling equipment selected. While polyvinyl chloride (PVC) pipe has frequently been used, this pipe potentially presents greater risk if it is exposed to a fire hazard where the pipe can melt. PVC should be used for biogas pipe below grade. Above grade, black iron pipe is highly recommended, and in some cases may be required by local building codes since it offers better mechanical protection. Biogas will eventually corrode black iron pipe, which will need to be replaced over time. Copper tubing and galvanized pipe should never be used.

Most digester systems eventually encounter conditions that result in foaming issues, and when this occurs, foam has the potential to reach the biogas pipeline. Changes in livestock feed rations and ingredients in non-manure feedstocks, or temperature fluctuations, are likely the causative agents. Once foam enters the biogas pipeline, the entire biogas utilization system must be shut down and completely cleaned. Any residues not cleaned out will eventually reach the EGS with negative effects. Management and monitoring of the digester on a daily basis are necessary to minimize

the occurrence of major clean-ups. The design of the biogas piping inside and outside the digester can affect how much the system will be affected by digester foaming; however, consideration should always be given to foam control systems, such as water spray nozzles in the gas line.

Because of its low thermal value, a higher biogas flow rate is required than needed when using conventional fuel gases. Proper sizing of biogas supply pipes and associated equipment must take into account the required flow rate, pipe length, number and type of bends, and resistance from equipment, such as meters and scrubbers installed in the delivery line. The addition of a blower or compressor is often necessary for raising line pressure enough to achieve required flow rates.

2.6 Biogas testing and monitoring

Biogas can be tested in both the field and in the laboratory, depending on the purpose of the testing and the resources available. In the field, testing can include both spot (single) measurements and continuous measurements to capture changes in the biogas over time.

2.6.1 Biogas field testing

There are many reasons for measuring biogas component concentrations on-farm, and the reason for doing so will usually dictate what sort of equipment can be used. CO₂ concentration is probably the most commonly taken measurement since high CO₂ levels indicate an upset digester (CH₄ concentration is usually estimated by subtraction of CO₂, as CH₄ and CO₂ are the primary gases in biogas).

Single Use Measurements

The oldest technology for measuring gas concentrations relies on colorimetry, which is the reaction of a reagent with the gas of interest to change color. A standard volume of sample gas is drawn through a tube filled with reagent, with graduated markings on the side. As the gas passes through the reagent it reacts and changes color. By reading the gradation the user can determine the concentration.

Tubes are available to measure all the components typically found in biogas, including CO₂, CH₄, H₂S, water vapor, O₂, etc. Calibrated tubes come in a variety of measurement ranges from parts

per billion (ppb) to 100%, depending on the concentration range of the constituent gas to be measured. This is an important consideration, as the most precise measurement relies on using a tube with the narrowest range, which requires knowledge of the approximate concentration before taking the measurement. Typically, a tube with a wider range is used first, after which a tube with a finer range can then be used.

Gas specific tubes can be purchased for a single use. H₂S tubes cost \$5 to \$10 with a shelf life of 2 years. In addition to the sample tubes, a calibrated tube pump is required (~\$500). Typically, tubes are purchased in boxes of 10. Some of the more commonly available brands are Draeger™, and Sensidyne™ (shown in Figure 10).



Figure 10. Sensidyne™ gas detector tubes (www.sensidyne.com).

Because there is a chemical reaction involved, these tubes can only be used one time. It is also critical that the correct volume of biogas be drawn through the tube by using the correct sampler at the recommended settings for the tube. For this reason, when sampling from a biogas line that is under pressure, it is necessary to first collect the biogas sample into a non-reactive Tedlar™ bag from which measurement can be made.

Pros:

- Good for quick, spot measurements

- Highly portable
- Relatively inexpensive for few measurements
- No need for calibrations
- No maintenance required
- No need for electricity
- Reliable

Cons:

- For most precise measurements need to know the approximate range of concentration being measured
- Need to manually sample, measure, and read value from tube.

Continuous Monitoring

When multiple repeated measurements are required, a system capable of automatically sampling and measuring is necessary. Typically, such systems use either a “tape” based colorimetric system (similar to the single use tubes), or an electrochemical or infrared cell.

With colorimetric systems, the target gas reacts with chemicals impregnated in the “tape” causing them to change color. The concentration of the measured gas is then proportional to the color change.

Electrochemical cells operate like a battery, and the change in current between the electrodes is proportional to the concentration of the measured gas.

Infrared sensors measure the absorbance of infrared light and can determine the concentration of gases, such as CH₄, CO₂ and O₂, based on the wavelengths absorbed. Infrared cells are much more robust and stable than electrochemical cells, and they require less frequent calibration and replacement. However, they are not suitable for all types of gas measurement. For example, infrared cells are not suitable for H₂S measurement, which is usually measured with an electrochemical cell.

Gas monitoring systems are typically set up so that they can measure the concentration of several gases at the same time, such as CH₄, CO₂, O₂ and H₂S. It is also common for such systems to have the ability to switch gas sampling points, monitoring each individual sample point for a set period of time (typically a minimum of 15 minutes). It takes time for the gas sensors to purge the previous gas measured and to react to a change in concentration and stabilize, so more frequent switching is not recommended.

It is also necessary to calibrate with a known concentration (“span”) of the target gases. This process can also be automated, but is typically carried out manually based on a recommended frequency from the manufacturer. For H₂S, monthly calibrations are recommended for best results. CH₄, CO₂ and O₂ can be calibrated yearly.

For best results, sensors should be compared frequently against a zero gas or ambient air to account for zero-drift and temperature effects. Usually this can be set up to occur automatically several times per day or based on a measured change in temperature.

In-situ systems typically cost \$20,000 to \$30,000, with replacement H₂S sensors approximately \$1,000. Common manufacturers of such systems include Siemens™, Geotech™, and Union Instruments™.

Hand-held systems are approximately \$5,000 - \$10,000, available from manufacturers such as, Geotech™, Gas Data™, Sewerin™, and Landtec™.

Advantages of in-situ monitoring:

- Automated sampling and potentially data collection
- Can be used for process control and compliance monitoring
- Equipment can measure several gases simultaneously
- Can capture changes in concentration over time readily

Disadvantages of in-situ monitoring:

- Capital cost intensive (expensive)
- Need to vent sampled gas

- Can require additional plumbing connections in addition to a sample port (vents, condensate drains etc.)
- Possible need to condition gas (remove moisture) for in-situ equipment (not necessary for hand-held units)
- Regular (monthly) calibrations and sensors need annual replacement
- Sensors are temperature sensitive (though there are techniques for correcting for temperature)

2.6.2 Biogas lab testing

The most accurate way to determine biogas composition is to analyze samples in a lab-based gas chromatograph (GC). To perform the analysis, biogas is collected in the field in a Tedlar® bag and analyzed in a lab GC as soon as possible, ideally less than 24 hours following sample collection. The exception is when analyzing H₂S. As time passes, the H₂S concentration results decrease, so the most reliable results are obtained within the first several hours after sample collection. In-situ analysis using gas analysis tubes is likely the more reliable method for this specific gas. Gas chromatograph equipment is generally not used for field testing because of the expense of the equipment, the requirement for a carrier gas (typically helium or nitrogen), and the fact that the value given is a single point measurement.

2.7 Biogas concerns

Because biogas is explosive, toxic and hazardous to humans, animals and equipment health, extreme care must be taken when working with and around it. A brief explanation of the most important dangerous gases and their impacts to human health, is shown in Figure 11.

Manure gas hazards

Confined spaces can be oxygen-deficient, toxic and explosive. There are four manure gases that are of primary concern.

Hydrogen Sulfide

A highly toxic gas that is heavier than air. It can cause dizziness, unconsciousness and death. At low concentrations it may smell like rotten eggs, but at higher concentrations it deadens the sense of smell so that no odor can be detected.

Carbon Dioxide

An odorless, tasteless gas that is heavier than air. It displaces the oxygen supply in the bloodstream, which can cause unconsciousness and death.

Ammonia

A gas that is lighter than air. It has a pungent smell and can irritate the eyes and respiratory tract. Ammonia also displaces oxygen in the bloodstream.

Methane

A gas that is lighter than air. The primary hazard of methane gas is that it can create an explosive atmosphere. This gas also displaces oxygen.

Figure 11. Dangerous manure gases and their impacts to human health.

2.7.1 Biogas safety

There are several hazards when working in or around biogas production systems. Completely covering these hazards is beyond the scope of this document; the information below is provided as an overview with recommendations for further reading.

The main issues to consider with regards to biogas handling safety are: human health risks due to exposure to certain gases (specifically H₂S), explosion when mixed with air in concentrations of 5 to 15% and pressure (with systems pressurizing clean biogas). The risks that biogas pressure poses to the system and to operators are reduced by incorporating sensors and pressure relief valves.

2.7.2 Sensors for Personal Safety Monitoring

Manure and biogas systems can involve situations that are potentially hazardous to health and for that reason, personal safety monitors are highly recommended (and may be required) for workers.

Typically, the user is not interested in the specific concentration of a gas rather when, or if, it exceeds (or drops below) a target threshold.

When working in enclosed spaces with machinery, it is important that the safety sensor notify the user through multiple senses. Typically, safety sensors will vibrate, flash, and chirp when an alarm condition is detected.

Explosivity

Since biogas is produced in an anaerobic environment, it only becomes an explosion hazard when mixed with a certain concentration of ambient air, in the range of 6 to 12% O₂ with 60% or greater quantities of CH₄ (Wellinger, 2000). The actual explosive limits for biogas are dependent on the concentration of CO₂, CH₄, and O₂ and should be determined for each mixture independently (Schroeder et. al., 2014). Some biogas H₂S reduction processes introduce ambient air at levels targeting less than 5% and such systems need to be carefully monitored in order to avoid addition of excessive air. Ambient air can also be introduced in potentially explosive limits during digester vessel filling or emptying (for in-vessel maintenance), as biogas production can still be occurring. H₂S is corrosive, poisonous, flammable, heavier than air and can collect in low lying areas and enclosed spaces, posing a severe risk to both human and animal health. Though the presence of H₂S can be readily detected at low concentrations through its characteristic odor, sensitivity to the odor is quickly lost when exposed to elevated concentrations, making it particularly dangerous to rely on smell alone for detection. OSHA states that concentrations above 100 ppm are immediately dangerous to life and health (OSHA, 2018). Inhaling a single breath of H₂S with a concentration above 1,000 ppm can lead to immediate collapse with a loss of breathing.

It is generally recommended that when working around manure storages or treatment systems, workers wear a H₂S personal gas monitor. The monitor can detect the presence of H₂S and alert the wearer when dangerous conditions are encountered. In addition, some systems have in-place combustible gas sensors in buildings housing the biogas utilization system.

It is not only the presence of dangerous gases that presents a risk, but additionally the absence of one very necessary gas – oxygen – that presents an equally dangerous situation for workers and

staff. When manure gas is produced in a confined space without ventilation, it displaces air, creating an atmosphere with insufficient oxygen to support human life. Covered manure storage and collection pits, digester tanks, covered lagoons, upright storage tanks and tanker spreaders are examples of places where manure gases can accumulate to produce a deadly atmosphere. The atmosphere can also be hazardous in an open manure pit. The Occupational Safety and Health Administration's (OSHA) Confined Space Standard (29 CFR 1910.146) regulates work in confined spaces. Confined spaces are those that have limited or restricted means of entry or exit, are large enough for a person to enter, and are not designed for occupancy. Confined space openings can be small and barely big enough to fit through or large like the top of some manure pits (Aldrich, 2005).

Further reading

Additional information on biogas safety can be found in the following documents:

- *Technician's Start-up and Operation guide* (Pronto et al., 2014).
- Dept. of Labor, Occupational Safety and Health Administration (OSHA) H₂S fact sheet (<https://www.osha.gov/SLTC/hydrogensulfide/standards.html>).
- *Conducting a Safety Walk-Through on a Farm: Hazards of the Manure Handling System, Anaerobic Digester, and Biogas Handling System.* Brown, N.J. (<http://manuremanagement.cornell.edu/Pages/Topics/Safety.html>)

2.7.3 Biogas corrosion

In addition to posing a hazard to human and animal health, biogas containing H₂S is highly corrosive and negatively affects equipment and equipment components.

- **Direct corrosion:** H₂S causes corrosion of metal, including iron and galvanized parts, and it causes severe corrosion of non-ferrous metals, such as brass, copper and aluminum. Care must be taken to ensure valves, pressure regulators, sensors, and other components in the gas flow path are compatible with H₂S.
- **Corrosion from sulfur dioxide:** Besides direct corrosion from H₂S, sulfur dioxide (SO₂) is formed when biogas is combusted in an EGS or boiler. When SO₂ reacts

with water it forms sulfuric acid, which is very corrosive to metal parts. Water is present both from vapor in the biogas and is also formed during the combustion process.

The formation of sulfuric acid is exacerbated when engines are started and stopped frequently, which increases the amount of condensation formed. Exhaust systems and metals exposed to exhaust (galvanized structures, etc.) are particularly susceptible to corrosion due to the high levels of SO₂ and water vapor.

SO₂ and water can also dissolve in the engine oil thus reducing pH, making the oil less able to lubricate components. For this reason, the properties of the engine oil need to be closely monitored and the oil changed at a frequency based on H₂S concentrations (with higher concentrations requiring increased changing frequency).

3 Biogas Clean-up

3.1 Introduction

Biogas clean-up can be performed at various levels, from simply removing moisture to more advanced clean-up strategies to produce biomethane (pure methane gas)/renewable natural gas (RNG) for injection to a natural gas pipeline or for use as transportation fuel. Biogas clean-up can be broken down into three general categories:

- **Basic:** removal of moisture for low pressure transport in a local pipeline
- **Mid:** removal of H₂S and sometimes moisture as well, in order to use biogas for on-site combustion
- **Advanced:** full or nearly complete removal of all other biogas contaminants, in order to meet a pipeline quality standard, including:
 - hydrogen sulfide
 - water vapor
 - carbon dioxide
 - ammonia
 - oxygen

To produce biomethane/RNG, the H₂S, moisture, carbon dioxide and trace gases in biogas must be significantly reduced using systems, such as the system shown in Figure 12.

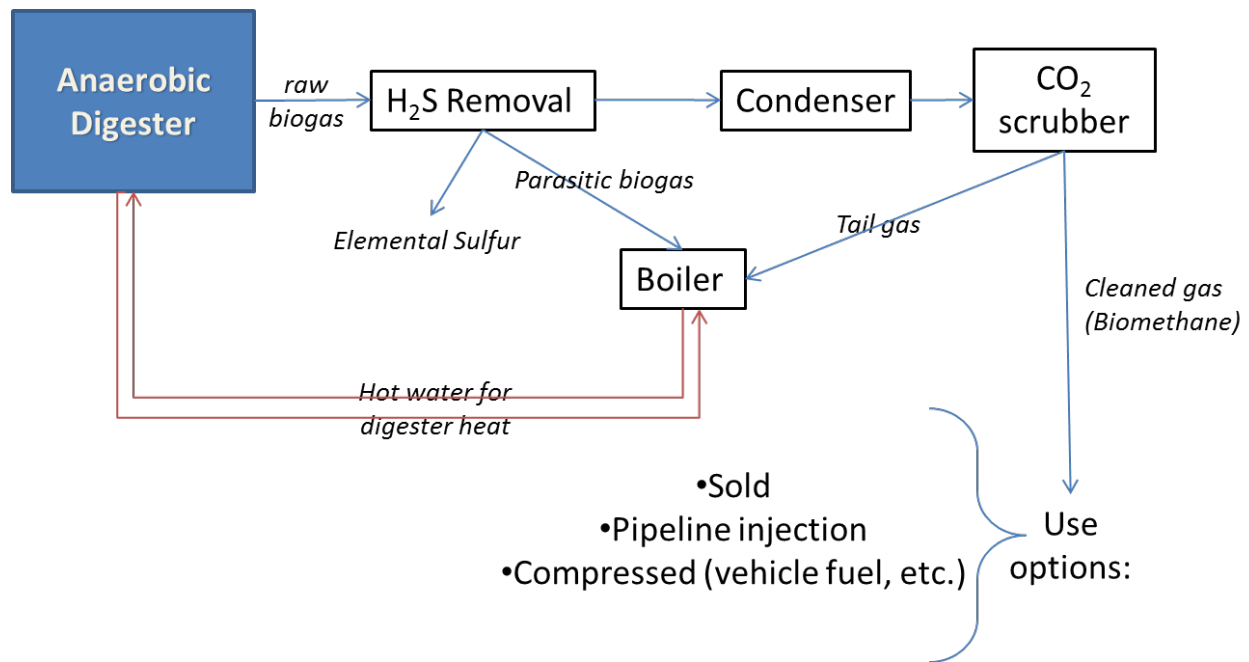

Figure 12. An AD with processes to produce biomethane (Gooch et al., 2010).

The following sub-sections outline several technologies that are utilized to remove or to significantly reduce specific contaminants from biogas. Several technologies can achieve reductions/removals of more than one of the contaminants.

3.2 Hydrogen sulfide removal

3.2.1 Physical/chemical

Physical/chemical treatment systems rely on media that reacts with the H₂S by converting/binding it. After time, when the media has reduced capacity to capture H₂S, it must either be regenerated (sometimes in-situ) or removed/discarded and replaced with new media. Iron sponge and activated carbon are two types of physical/chemical treatment; each are discussed below.

Iron sponge

An iron sponge system consists of iron oxide impregnated bark media contained within an above ground, usually cylindrical, tank located between the digester and biogas utilization system. An example is shown in Figure 13. One media supplier's product is stated to contain 15 pounds of

iron oxide per 1 bushel of wood bark media (one bushel of wood bark occupies 1 cubic foot of space in the tank).



Figure 13. Iron sponge biogas clean-up system on a central NYS dairy farm AD system (Source: C. Gooch).

The chemical reaction that occurs within an iron sponge system at ambient temperature is a bond between sulfur and iron oxide. Alkaline conditions must be present to support this reaction, with a pH greater than 7.5. If the pH drops below 7, sodium bicarbonate is added to the trickle water to increase pH.

For each pound of iron oxide (FE_2O_3) present in the system, 0.56 pounds of sulfide can be removed from the biogas. Iron oxide can be regenerated by adding air (O_2), which prolongs the life of the media, however the regeneration is not complete and typically 30% of the reaction capacity is lost each time. Through this process, the sulfide is changed to elemental sulfur. Spent iron sponge material (when H_2S is no longer removed and/or when the wood bark has deteriorated) can be burned (where permitted), landfilled, or spread on agricultural land.

The tank should have a diameter to active height ratio of 1:1 to 1:15 in order to promote uniform exposure of the biogas to the bark media and to limit the pressure drop across the media, which is

typically 2-3” water column initially and 8-10” after the system has been utilized for treatment for some time. A biogas blower is needed to force the biogas through the iron sponge and must be appropriately sized and selected based on its ability to withstand the corrosive nature of untreated biogas.

Commercially available iron sponge clean-up systems (Figure 14) include in-vessel spray systems to ensure the wood chips are saturated with moisture. However, since dairy manure-derived biogas is saturated with moisture and the vessel will be operating at a temperature less than the temperature of the biogas as it exits the digester (in the northeast), condensation will occur in the vessel. Biogas condensation in-vessel has shown to produce excessive moisture, so there is no need to operate an in-vessel spray system, except when the iron sponge system is located downstream of a condenser system for moisture removal. The vessels must have a condensate drain at the bottom to drain off excessive moisture into an appropriate receptacle.

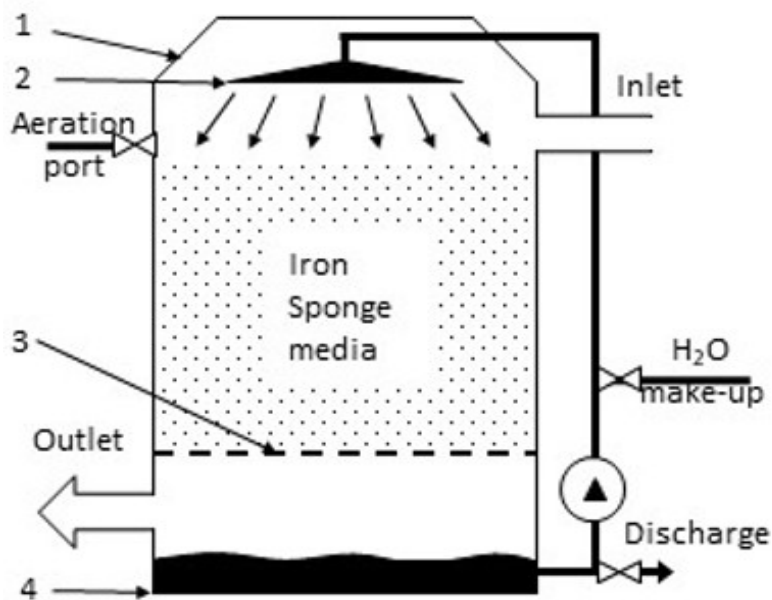

Figure 14. Typical cross sectional view of an iron sponge H₂S scrubber; 1) reaction vessel containing bark impregnated with ferric oxide (Fe₂O₃), 2) misting system to maintain moisture level and pH, 3) support for the impregnated bark, 4) reservoir of surplus recirculated water (Source: Shelford and Gooch, 2017).

Ideally, multiple tanks are used so one or more tanks are always available to process biogas, allowing the opportunity for one to be regenerated or for the media to be replaced. With multiple tanks, a piping system that is strategically laid out provides flexibility in biogas flow directions so the tank with the newest or most recently regenerated iron sponge is providing the final cleaning

set, as shown in Figure 15. The system should be valved for in-series use with the ability to isolate each tank as needed.

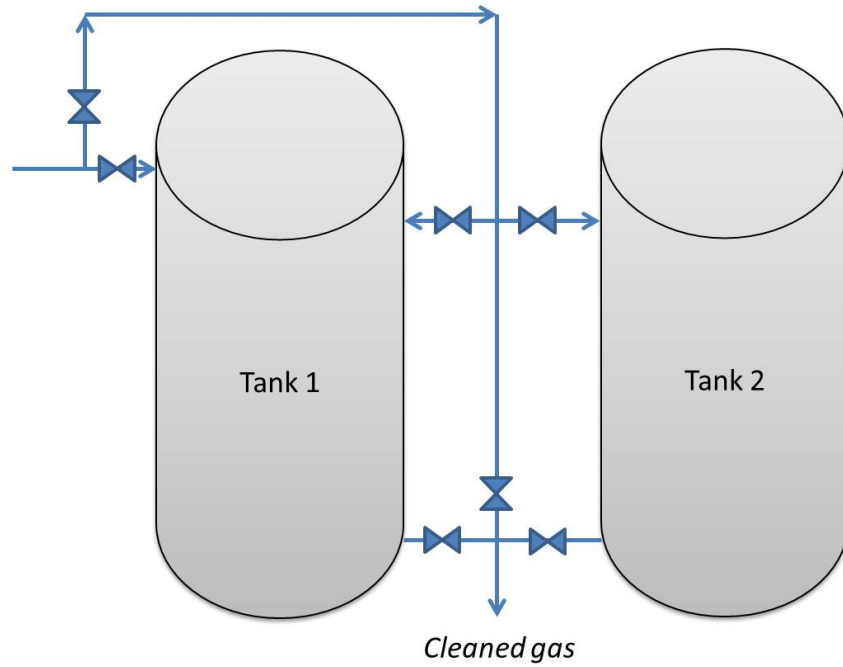

Figure 15. H₂S scrubber system with multiple tanks, providing the opportunity to regenerate the media in one tank while continuing to process biogas in the other(s).

Anticipated H₂S removal and associated iron sponge media costs based on biogas production and initial H₂S concentration are shown in Table 6. The required size of iron sponge reactor vessel and minimum cleanout frequency as a function of farm size (biogas flow) and the reduction in concentration of H₂S is provided in Table 7.

Table 6. Iron sponge media costs as a function of farm size and AD influent, with associated estimated biogas production, and H₂S concentration reduction.

Farm size (LCE ¹)	AD influent	Biogas production (CFM ⁴)	Mass H ₂ S (lbs/day) removed and media cost ² per day based on H ₂ S concentration reduction (ppm ³)									
			500 ppm removed		1,000 ppm removed		1,500 ppm removed		2,000 ppm removed		3,000 ppm removed	
100	Manure only	7,900	0.34	\$0.49	0.69	\$0.98	1.03	\$1.47	1.37	\$1.96	2.06	\$2.94
100	+10% Whey	8,690	0.38	\$0.54	0.76	\$1.08	1.13	\$1.62	1.51	\$2.16	2.27	\$3.24
100	+10% FOG	12,874	0.56	\$0.80	1.12	\$1.60	1.68	\$2.40	2.24	\$3.20	3.36	\$4.80
250	Manure only	19,750	0.86	\$1.23	1.72	\$2.45	2.58	\$3.68	3.44	\$4.91	5.15	\$7.36
250	+10% Whey	21,725	0.94	\$1.35	1.89	\$2.70	2.83	\$4.05	3.78	\$5.40	5.67	\$8.10
250	+10% FOG	32,185	1.40	\$2.00	2.80	\$4.00	4.20	\$6.00	5.60	\$8.00	8.40	\$12.00
500	Manure only	39,500	1.72	\$2.45	3.44	\$4.91	5.15	\$7.36	6.87	\$9.81	10.31	\$14.72
500	+10% Whey	43,450	1.89	\$2.70	3.78	\$5.40	5.67	\$8.10	7.56	\$10.80	11.34	\$16.19
500	+10% FOG	64,370	2.80	\$4.00	5.60	\$8.00	8.40	\$12.00	11.20	\$15.99	16.79	\$23.99
1,000	Manure only	79,000	3.44	\$4.91	6.87	\$9.81	10.31	\$14.72	13.74	\$19.63	20.61	\$29.44
1,000	+10% Whey	86,900	3.78	\$5.40	7.56	\$10.80	11.34	\$16.19	15.11	\$21.59	22.67	\$32.39
1,000	+10% FOG	128,741	5.60	\$8.00	11.20	\$15.99	16.79	\$23.99	22.39	\$31.99	33.59	\$47.98
1,500	Manure only	118,500	5.15	\$7.36	10.31	\$14.72	15.46	\$22.08	20.61	\$29.44	30.92	\$44.17
1,500	+10% Whey	130,350	5.67	\$8.10	11.34	\$16.19	17.00	\$24.29	22.67	\$32.39	34.01	\$48.58
1,500	+10% FOG	193,111	8.40	\$12.00	16.79	\$23.99	25.19	\$35.99	33.59	\$47.98	50.38	\$71.97
2,000	Manure only	158,000	6.87	\$9.81	13.74	\$19.63	20.61	\$29.44	27.48	\$39.26	41.22	\$58.89
2,000	+10% Whey	173,800	7.56	\$10.80	15.11	\$21.59	22.67	\$32.39	30.23	\$43.18	45.34	\$64.78
2,000	+10% FOG	257,481	11.20	\$15.99	22.39	\$31.99	33.59	\$47.98	44.78	\$63.98	67.18	\$95.96
2,500	Manure only	197,500	8.59	\$12.27	17.18	\$24.54	25.76	\$36.80	34.35	\$49.07	51.53	\$73.61
2,500	+10% Whey	217,250	9.45	\$13.49	18.89	\$26.99	28.34	\$40.48	37.79	\$53.98	56.68	\$80.97
2,500	+10% FOG	321,852	13.99	\$19.99	27.99	\$39.99	41.98	\$59.98	55.98	\$79.97	83.97	\$119.96
3,000	Manure only	237,000	10.31	\$14.72	20.61	\$29.44	30.92	\$44.17	41.22	\$58.89	61.83	\$88.33
3,000	+10% Whey	260,700	11.34	\$16.19	22.67	\$32.39	34.01	\$48.58	45.34	\$64.78	68.01	\$97.16
3,000	+10% FOG	386,222	16.79	\$23.99	33.59	\$47.98	50.38	\$71.97	67.18	\$95.96	100.76	\$143.95
4,000	Manure only	316,000	13.74	\$19.63	27.48	\$39.26	41.22	\$58.89	54.96	\$78.52	82.44	\$117.77
4,000	+10% Whey	347,600	15.11	\$21.59	30.23	\$43.18	45.34	\$64.78	60.46	\$86.37	90.69	\$129.55
4,000	+10% FOG	514,963	22.39	\$31.99	44.78	\$63.98	67.18	\$95.96	89.57	\$127.95	134.35	\$191.93

¹Lactating cow equivalent

²Assuming \$12 per bushel of media, no regeneration; 15 lbs. of iron per bushel and 0.56 lbs. of iron required to react with 1 lb. H₂S

³cubic feet per minute

⁴parts per million

Table 7 : Iron sponge vessel size and frequency of media cleanout (with and without regeneration) as a function of farm size and AD influent, with associated estimated biogas production, and H₂S concentration reduction.

Farm size (LCE ¹)	AD influent	Biogas production (CFM ³)	Vessel size (ft ³) and frequency of cleanout (days) with and without regeneration ²											
			500 ppm ⁴ removed				1,000 ppm removed				2,000 ppm removed			
			regeneration		no regeneration		regeneration		no regeneration		regeneration		no regeneration	
100	Manure only	5	13	197	13	90	25	197	25	90	50	197	50	90
100	+10 % Whey	6	14	217	14	99	28	217	28	99	55	217	55	99
100	+10 % FOG	9	20	321	20	147	41	321	41	147	82	321	82	147
250	Manure only	14	31	197	31	90	63	197	63	90	125	197	125	90
250	+10 % Whey	15	34	217	34	99	69	217	69	99	138	217	138	99
250	+10 % FOG	22	51	321	51	147	102	321	102	147	204	321	204	147
500	Manure only	27	63	197	63	90	125	197	125	90	251	197	251	90
500	+10 % Whey	30	69	217	69	99	138	217	138	99	276	217	276	99
500	+10 % FOG	45	102	321	102	147	204	321	204	147	409	321	409	147
1,000	Manure only	55	125	197	125	90	251	197	251	90	502	197	502	90
1,000	+10 % Whey	60	138	217	138	99	276	217	276	99	552	217	552	99
1,000	+10 % FOG	89	204	321	204	147	409	321	409	147	818	321	818	147
1,500	Manure only	82	188	197	188	90	376	197	376	90	752	197	752	90
1,500	+10 % Whey	91	207	217	207	99	414	217	414	99	828	217	828	99
1,500	+10 % FOG	134	307	321	307	147	613	321	613	147	1,226	321	1,226	147
2,000	Manure only	110	251	197	251	90	502	197	502	90	1,003	197	1,003	90
2,000	+10 % Whey	121	276	217	276	99	552	217	552	99	1,104	217	1,104	99
2,000	+10 % FOG	179	409	321	409	147	818	321	818	147	1,635	321	1,635	147
2,500	Manure only	137	314	197	314	90	627	197	627	90	1,254	197	1,254	90
2,500	+10 % Whey	151	345	217	345	99	690	217	690	99	1,380	217	1,380	99
2,500	+10 % FOG	224	511	321	511	147	1,022	321	1,022	147	2,044	321	2,044	147
3,000	Manure only	165	376	197	376	90	752	197	752	90	1,505	197	1,505	90
3,000	+10 % Whey	181	414	217	414	99	828	217	828	99	1,655	217	1,655	99
3,000	+10 % FOG	268	613	321	613	147	1,226	321	1,226	147	2,453	321	2,453	147
4,000	Manure only	219	502	197	502	90	1,003	197	1,003	90	2,007	197	2,007	90
4,000	+10 % Whey	241	552	217	552	99	1,104	217	1,104	99	2,207	217	2,207	99
4,000	+10 % FOG	358	818	321	818	147	1,635	321	1,635	147	3,270	321	3,270	147

¹Lactating cow equivalent

²Assuming 15 lbs. of iron per bushel and 0.56 lbs. of iron required to react with 1 lb. H₂S and two regenerations with 30% capacity lost per regeneration

³cubic feet per minute

⁴parts per million

3.2.2 Microbial fixation

Microbes (bacteria) that naturally develop on surfaces in certain low-oxygen environments, such as a digester vessel biogas headspace, can be used to reduce biogas H₂S concentrations. Sulfur oxidizing bacteria (SOB) obtain energy from H₂S and oxygen (O₂), and carbon from carbon dioxide (CO₂). With a limited oxygen supply into the headspace of the digester or a separate vessel, SOB can feed on the H₂S and reduce H₂S concentration in the biogas. The biological breakdown of H₂S can be described by Reactions 1 thru 4 below.

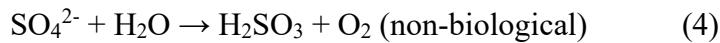
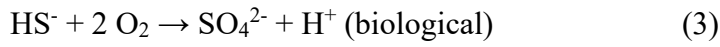
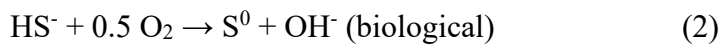

Anaerobic digester vessel biogas headspace and separate vessel biological H₂S reduction methods are discussed in the following sections.

Vessel headspace

During air injection (micro-aeration), a regulated amount of O₂, between 0.3 to 3% of produced biogas, is injected into the headspace of a digester to create a micro-aerobic environment. Normally, air (21% O₂, 79% N₂) is used to provide this O₂ source, resulting in an air dosage range of 1.5% to 15% of produced biogas to create the desired O₂ concentration (Figure 16). This is a variable range because the airflow rate needed to convert H₂S to elemental sulfur is dependent on both the sulfur concentrations in the feedstock and the biogas production rate.

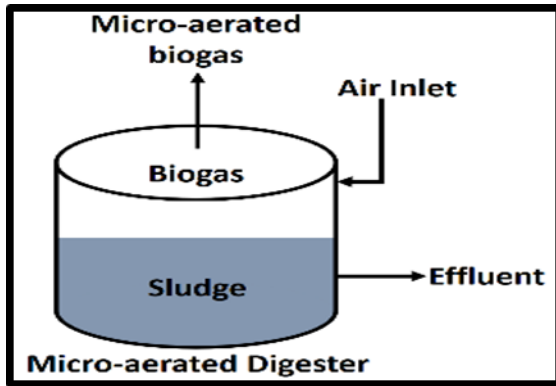

Figure 16. A basic representation of in-situ air injection.

A properly controlled micro-aerobic environment can remove H_2S without large reductions in biogas production and quality. In this case, elemental sulfur (S) is produced when O_2 concentration is limited within a micro-aerobic environment. The controlled micro-aerobic environment causes elemental sulfur to accumulate on the walls and the headspace of the digester where SOB grow, as seen in Figure 17. If too much sulfur builds-up, H_2S removal efficiency may decrease due to decreased biogas residence time and O_2 transfer rates (Muñoz, 2015). When removal efficiencies significantly drop, the S build-up needs to be removed to help increase H_2S removal. The clean-out can require the removal of the digester top, which can be expensive and result in increased digester downtime.

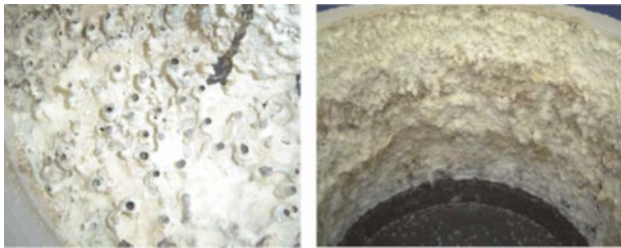

Figure 17. Accumulation of elemental sulfur on the walls and headspace of digester (Díaz, 2012).

Sulfur concentrations entering the digester vary due to changing sulfur concentrations in the feedstock, which affects H_2S concentration. The O_2 flow should be controlled to match changing sulfur feedstock concentrations. A handheld gas analyzer or tubes, described in Section 2.6.1, can be used to monitor biogas composition (CH_4 , CO_2 , O_2 , and H_2S), and the information used to adjust air flow into the AD headspace. Maintaining O_2 levels between 0.3% and 0.5% will keep H_2S

concentrations between 100 and 500 ppm (Mulbry, 2017). While air injection does decrease CH₄ and CO₂ concentrations in the biogas with increasing air additions due to N₂ addition, studies have shown that when the O₂ concentration was less than or equal to 1% O₂, there was no apparent effect from aeration on the CH₄ production rate. This is most likely because the methanogens are found in the digester substrate, unexposed to the oxygen.

It is important to be aware that overdosing of air can be a safety issue. Incorporating oxygen into biogas can result in an explosive mixture in the range of 6 to 12% O₂ when the concentration of CH₄ is 60% or higher (Wellinger, 2000). If the airflow control stops working, there is a potential for an explosive mixture to occur.

In addition to safety considerations, air injection should be monitored closely to maintain biogas quality. Air is made up of 79% nitrogen in an inert form, N₂. The unreactive nature of nitrogen causes it to combine with the biogas, diluting the methane percentage. Additionally, any excess oxygen that has not been used can contribute to the dilution of the biogas. Lower methane percentages may adversely affect generator performance for electricity production and should not be used with RNG applications due to this dilution effect.

Biological Trickling Filters

Biotrickling filters (BTF) are irrigated reactors with a packed bed colonized by SOB, where a nutrient water ‘trickles’ through the packed media from the top. As raw biogas is blown through the media, H₂S is removed from the biogas and metabolized by SOB. Sulfur-laden nutrient water is recirculated, and periodically discharged and replenished with make-up water. Air and recycled nutrient water support the activity of the SOB. The nutrient water also aids in pollutant capture, such as dust and dirt particles, and removal of the sulfate waste generated by SOB. The excess moisture in biogas can affect the performance of the generator by lowering the heating value. A demister can be used to separate water droplets from gas to dry the cleaned biogas (Figure 18).

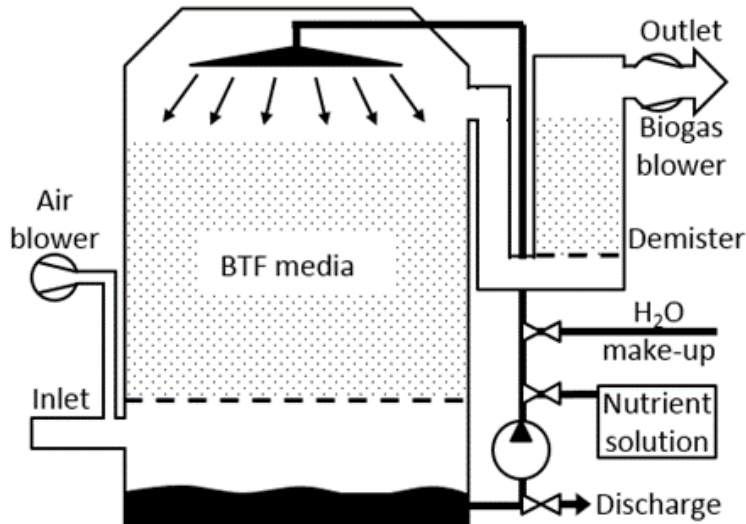

Figure 18. Cross-section of typical biogas biotrickling filter design. Raw-biogas enters at the inlet and treated-biogas leaves the outlet. Trickle phase (sulfur-laden) nutrient water is recirculated, and periodically discharged and replenished with make-up water and nutrients (Source: Oliver and Gooch, 2016).

A BTF must be large enough to handle the maximum biogas flow rate and H₂S concentration. When biogas H₂S concentration is not known, required BTF vessel size can be estimated using the flow rate and a rule of thumb for empty bed residence time using the equation below.

$$V_f = \text{EBRT} * Q$$

where V_f = volume of filter media (ft³),

EBRT = empty bed retention time (minutes), and

Q = flow rate (biogas and air combined) through the system (ft³/min.).

In the Northeast US, a typical BTF uses a 7 to 8 min EBRT. With flow rates of 100 to 400 cfm, farms may need media volumes of 700 to 2,800 ft³, resulting in 20 to 40 ft. tall and 8 to 12 ft. in diameter vessels depending on the gas flow rate. Longer EBRTs are required for higher H₂S biogas concentrations. In NYS, typical H₂S concentrations of dairy-based biogas are 500 to 6,000 ppm. When biogas concentration is known, required biofilter volumes can be estimated using a rule of thumb for the volumetric loading rate of H₂S using the equation below.

$$V_F = (Q \times CG / LR) \times 0.0000624$$

where CG is the biogas H₂S concentration (lb/ft³)

and LR is the H₂S loading rate (lb/ft³/h)

and 1ppm = 0.0000624 lbs/ft³.

Typical BTF hourly loading rates for systems in the Northeast are 0.18 to 0.20 lb H₂S/ft³-h.

Relative to the downward flow of the nutrient water, flow of the biogas can be co-, cross- or counter-current. While co-current configurations have been used, they typically have lower desulfurization performances than cross- or counter-current designs. Desulfurization is the process of removal of sulfur or sulfur compounds. Counter-current configurations have the highest potential performance due to their high driving forces for absorption. Cross-flow configurations offer the advantages of lower pressure drop than counter-flow designs and may be less susceptible to uneven water distribution in the media, but their shorter residence times reduce desulfurization potential. Blowers must be capable of overcoming the pressure drop of the system and meet the supply needs of the biogas-fueled EGS. Most BTFs installed in the Northeast are counter-current.

The trickling nutrient water must be delivered evenly to the media to prevent localized drying and channeling of biogas. Spray nozzles must resist corrosion and fouling while delivering a mist small enough to provide large surface area, yet large enough to be captured by the demister or other water removal devices (e.g. chillers). Nutrient water is re-circulated to reduce water usage. When the concentration of accumulated breakdown products (e.g. sulfates) becomes too high, a portion of the recirculating water must be replaced with fresh water. This can be controlled by a time set-point, pH meters, and/or electrical conductivity meters. For many systems in the Northeast US, most desulfurizing BTFs are flushed every 2 hours but are also equipped with a pH meter and/or a conductivity meter.

Ideal BTF media has high surface area for microbial attachment, high bulk porosity to permit air flow, chemical and structural stability to ensure longevity, is light-weight, and affordable. Pall or Raschig rings, moving bed bioreactor (MBBR) media, bioballs, or foam cubes can all be used. In NYS, BTF are randomly packed with polypropylene Pall rings or MBBR media (Figure 19).

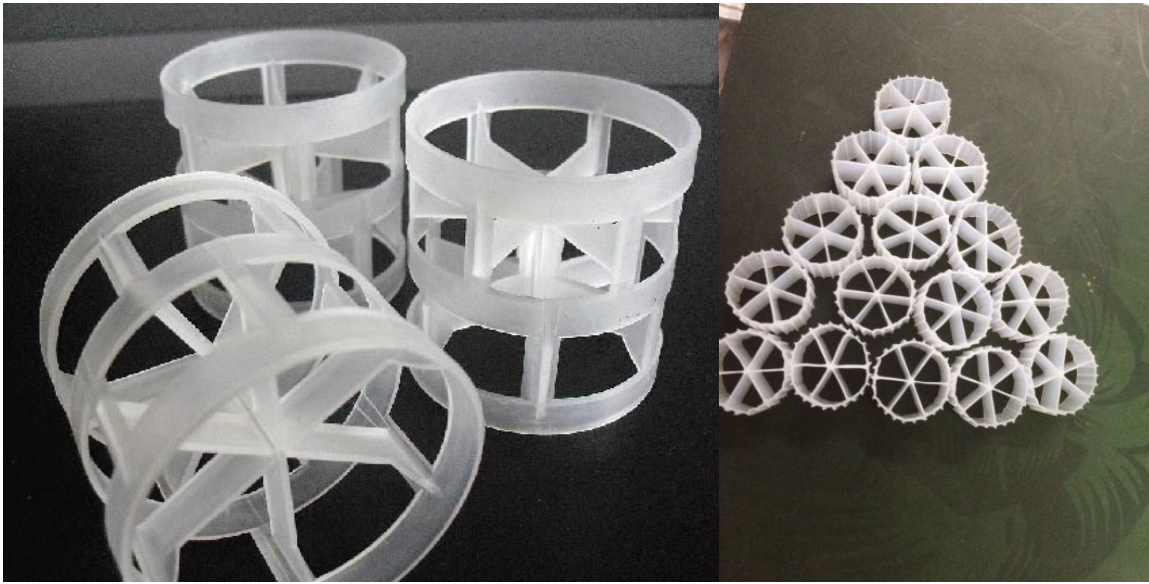

Figure 19. Examples of BTF Media. Pall rings (left) and MBBR media (right) (Aquatech International).

BTF for biogas H_2S removal typically operate under mesophilic conditions (70 to 110°F) using reclaimed heat from the biogas-fueled EGS (when co-localized) or an auxiliary boiler system. In NYS, most BTFs are operated near 90°F. To supply oxygen, air is typically fed into a BTF at 10-12% of the gas flow using a blower. The target vessel oxygen concentration is ~2%. BTF for biogas H_2S removal can operate at neutral (pH 6-8) and acidic (pH 1-5) conditions. Both designs can achieve high performances though rapid pH changes can impact H_2S removal rates. Most BTF systems in NYS operate under acidic conditions (pH 1-2).

Hydrogen sulfide removal efficiencies of 80 to 100% have been measured by the authors for inlet H_2S concentrations of 2,000 to 12,000 ppm. Capital costs can be \$200,000 - \$300,000 for 2,000 - 4,000 cow dairies, with operating costs in materials, labor, and maintenance around \$20,000/yr.

BTF reactor vessel size, heat and electricity requirement (based on typical climatic conditions for the Northeast US) and nutrient usage is shown in Table 8.

Table 8. Biological trickling filter treatment system size, heat and electricity requirement, and nutrient cost as a function of farm size and AD feedstock (biogas production) and H₂S concentration removal.

Farm size (LCE ¹)	AD influent	Biogas production (CF/day)	Biological Trickling Filter vessel size (ft ³), annual utility ² and nutrient usage							
			1,000 ppm				2,000 ppm			
			Size (ft ³)	Heat used (MMBtu/yr)	Electricity (kWh/yr)	Nutrient cost (\$/yr)	Size (ft ³)	Heat used (MMBtu/yr)	Energy used (kWh/yr)	Nutrient cost (\$/yr)
100	Manure only	7,900	34	4	536	39	68	8	1,071	79
100	+10% Whey	8,690	37	4	589	43	75	9	1,179	86
100	+10% FOG	12,874	55	7	873	64	111	13	1,746	128
250	Manure only	19,750	85	10	1,339	98	170	20	2,679	196
250	+10% Whey	21,725	93	11	1,473	108	187	22	2,946	216
250	+10% FOG	32,185	138	16	2,183	160	277	33	4,365	320
500	Manure only	39,500	170	20	2,679	196	339	40	5,357	393
500	+10% Whey	43,450	187	22	2,946	216	373	45	5,893	432
500	+10% FOG	64,370	277	33	4,365	320	553	66	8,730	640
1,000	Manure only	79,000	339	40	5,357	393	679	81	10,714	786
1,000	+10% Whey	86,900	373	45	5,893	432	747	89	11,786	864
1,000	+10% FOG	128,741	553	66	8,730	640	1,106	132	17,460	1,280
1,500	Manure only	118,500	509	61	8,036	589	1,018	121	16,071	1,179
1,500	+10% Whey	130,350	560	67	8,839	648	1,120	134	17,679	1,296
1,500	+10% FOG	193,111	830	99	13,095	960	1,659	198	26,190	1,921
2,000	Manure only	158,000	679	81	10,714	786	1,358	162	21,429	1,571
2,000	+10% Whey	173,800	747	89	11,786	864	1,493	178	23,571	1,729
2,000	+10% FOG	257,481	1,106	132	17,460	1,280	2,212	264	34,921	2,561
2,500	Manure only	197,500	849	101	13,393	982	1,697	202	26,786	1,964
2,500	+10% Whey	217,250	933	111	14,732	1,080	1,867	223	29,464	2,161
2,500	+10% FOG	321,852	1,383	165	21,825	1,601	2,766	330	43,651	3,201
3,000	Manure only	237,000	1,018	121	16,071	1,179	2,036	243	32,143	2,357
3,000	+10% Whey	260,700	1,120	134	17,679	1,296	2,240	267	35,357	2,593
3,000	+10% FOG	386,222	1,659	198	26,190	1,921	3,319	396	52,381	3,841
4,000	Manure only	316,000	1,358	162	21,429	1,571	2,715	324	42,857	3,143
4,000	+10% Whey	347,600	1,493	178	23,571	1,729	2,987	356	47,143	3,457
4,000	+10% FOG	514,963	2,212	264	34,921	2,561	4,425	528	69,841	5,122

¹Lactating cow equivalent

²Annual utility usage will vary due to location. Values provided are based on a specific Upstate NYS location.

3.2.3 Digester influent additives

Another way to remove H₂S from biogas is to add a compound into the digester influent that will directly react with the H₂S produced before it has an opportunity to leave the digester. Such compounds are typically added to the digester influent pit before the manure is pumped into the digester. Chemical options include ferric chloride (liquid) and ferric hydroxide (powder). Overall, one advantage digester influent additives have over post-AD biogas scrubbing is significantly reduced capital and maintenance and repair costs. Ferric chloride comes in totes and is metered into the digester influent using a simple dosing pump while ferric hydroxide comes in paper reinforced bags (approximately 40 lbs.) and the whole bag can simply be tossed into the influent pit. For the latter, aggressive impeller mixing is required to break the bag and to completely mix contents with the digester influent.

Ferric chloride dosing

Iron chloride can be injected directly into a digester by an automated dosing unit, but is more likely added to the digester influent pit. The iron chloride reacts with H₂S to form insoluble iron sulfide salt particles, which can settle out of the digester within the digester tank or in the effluent. Ferric chloride dosing is good for treating high initial H₂S concentrations, as the first step in a multi-stage removal process.

Initial costs are low, particularly if the sacks of media are manually added to the influent, but the operating cost can be high due to chemical cost. The New York State Research and Development Authority (NYSERDA) funded a project at AA Dairy in 2009 to explore the effectiveness of treating digestate in this manner. In the on-farm demonstration portion of the study, an iron chloride concentration of 150 mg/L resulted in a reduction of approximately 40% of the sulfide concentration in the biogas produced by the AD. Further reduction in biogas H₂S concentration (60% or more) was not achieved, likely due to significant sinks/binding of iron ions in the digestate. Lack of mixing and high suspended solids in the digestate appear to be inherent disadvantages for using iron dosing systems to remove biogas H₂S content in plug-flow digesters specifically. The use of ferrous chloride as compared with ferric chloride did not seem to change the effectiveness of the iron salts at reducing H₂S concentrations in the field (when compared on a similar weight basis). No measurable changes in the CH₄ and CO₂ content in the biogas stream

were observed due to the iron addition, suggesting that iron was not a limiting nutrient under the digester operational parameters prevailing during this investigation. Formation and/or precipitation of iron sulfides did not result in a measurable increase in the total solids concentration in the digester, thus there is minimal potential for clogging of AD piping due to this process. Direct addition of ferric chloride and ferrous chloride to dairy farm digesters can be an effective method to reduce the H₂S concentration in the biogas produced from the digesters. Further investigation into minimizing the effects of iron sinks/binding in the digester bulk liquid matrix, such as enhanced delivery and digester mixing, offer the potential to further improve performance (NYSERDA, 2012).

Ferric hydroxide dosing

Ferric hydroxide, a dark orange compound; oxidizes reduced sulfurous compounds in the digester influent that helps reduce biogas H₂S concentrations. Ferric hydroxide can remove H₂S from aqueous systems through oxidation and precipitation reactions within the operating pH range of most digesters (6.5 to 8.5) through the following reactions:

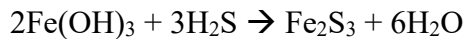
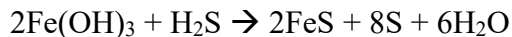

Fe₂S₃ is unstable and breaks down into FeS₂ and Fe₃S₄. Even though ferric hydroxide can be used as a direct additive for biogas desulfurization, it is more commonly used in a separate biogas scrubbing vessel. The possibility of regeneration is a major advantage of using ferric hydroxide in a separate scrubbing vessel. The iron sulfide can react with oxygen in the air and convert back to ferric oxide and ferric hydroxide (in a humid environment), as seen in the following reactions:

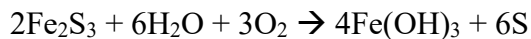
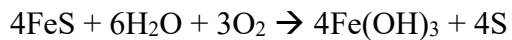

Ferric hydroxide has been used primarily in the wastewater treatment industry, with a constant daily dose necessary to maintain a low output of H₂S concentration. It is important to estimate the required quantity of ferric hydroxide needed based on the volume of biogas produced; approximate

amounts and costs are shown in Table 9. The actual amount used can be determined based on measuring biogas volume and H₂S concentration.

Table 9. Ferric hydroxide and iron chloride daily usage and cost for H₂S reduction as a function of biogas production based on farm size and AD influent.

Farm size (LCE ¹)	AD influent	Biogas production (CF/day)	Ferric hydroxide		Iron chloride	
			lbs./day	\$/day ²	lbs./day	\$/day ³
100	Manure only	7,900	8	3	6	5
100	+10% Whey	8,690	9	3	6	6
100	+10% FOG	12,874	13	5	9	8
250	Manure only	19,750	20	7	14	13
250	+10% Whey	21,725	22	8	16	14
250	+10% FOG	32,185	32	12	23	20
500	Manure only	39,500	40	14	28	25
500	+10% Whey	43,450	44	16	31	28
500	+10% FOG	64,370	65	23	46	41
1,000	Manure only	79,000	80	29	57	50
1,000	+10% Whey	86,900	88	31	63	55
1,000	+10% FOG	128,741	130	47	93	82
1,500	Manure only	118,500	119	43	85	75
1,500	+10% Whey	130,350	131	47	94	83
1,500	+10% FOG	193,111	195	70	139	122
2,000	Manure only	158,000	159	57	114	100
2,000	+10% Whey	173,800	175	63	125	110
2,000	+10% FOG	257,481	260	93	185	163
2,500	Manure only	197,500	199	72	142	125
2,500	+10% Whey	217,250	219	79	156	138
2,500	+10% FOG	321,852	324	117	232	204
3,000	Manure only	237,000	239	86	171	150
3,000	+10% Whey	260,700	263	94	188	165
3,000	+10% FOG	386,222	389	140	278	245
4,000	Manure only	316,000	318	115	227	200
4,000	+10% Whey	347,600	350	126	250	220
4,000	+10% FOG	514,963	519	187	371	327

¹Lactating cow equivalent

²Based on a Ferric Hydroxide cost of \$0.08 per pound

³Based on an Iron Chloride cost of \$0.14 per pound

The advantage of using ferric hydroxide as an additive to the digester is the potential benefit of precipitating out phosphorous from the feed. The reduced iron in the anaerobic environment can bind with the dissolved phosphate, forming ferrous phosphate precipitate.

3.3 Moisture removal

Another significant component of biogas is moisture. Typically, manure-derived biogas is saturated with moisture (e.g., biogas at a temperature of 100°F and flowrate of 100 CFM will contain about 50 gallons of water a day). This moisture can negatively affect biogas quality, and its removal may be required depending upon the distance biogas is piped between the digester and the end use equipment and/or on the specifics of the end use equipment.

Benefits of moisture removal include:

- **Improved combustion:** Reducing the moisture component of the biogas increases the proportion of the gas that is methane. Depending on biogas temperature, water vapor may represent up to 6% of the volume of the biogas.
- **Improved biogas equipment longevity:** Condensation of the biogas water vapor can negatively affect biogas equipment in a number of ways. Condensed water can react with H₂S to form sulfuric acid (and to a lesser extent CO₂, to form carbonic acid), which in turn can erode metal components of the biogas system. In addition, these acids can contaminate the engine oil, causing it to lose its lubricating properties. Free water can also wash oil from the cylinder heads.
- **Partial removal of water-soluble components of biogas.** Gases, such as H₂S and ammonia, typically found in biogas are also water-soluble. Depending on the process used to remove the moisture from the biogas, some of these contaminants may be removed/reduced at the same time.

Moisture removal/reduction may also be a requirement for certain biogas treatment technologies or end uses as well, although other treatment systems may benefit (iron sponge) or be unaffected (biological trickling filter) by the presence of moisture. Pipeline quality biogas requires the removal of moisture.

There are several strategies to remove moisture from biogas: passive moisture removal (condensate trap), refrigeration, use of adsorption agents, and pressure swing adsorption (described in detail in the carbon dioxide removal section). These strategies are discussed in the paragraphs below.

3.3.1 Passive

The simplest method to remove moisture from biogas is a passive strategy that uses the temperature differential of the biogas leaving the digester and the biogas being piped underground. The ground cools the biogas piping material which, in turn, results in some of the moisture contained in the saturated biogas to condense to liquid.

A condensate trap at the end or low point of the biogas pipe collects condensed moisture. This strategy is shown in Figure 20. For long underground pipe runs, multiple condensations traps may be needed, especially at low spots where condensate will naturally accumulate.

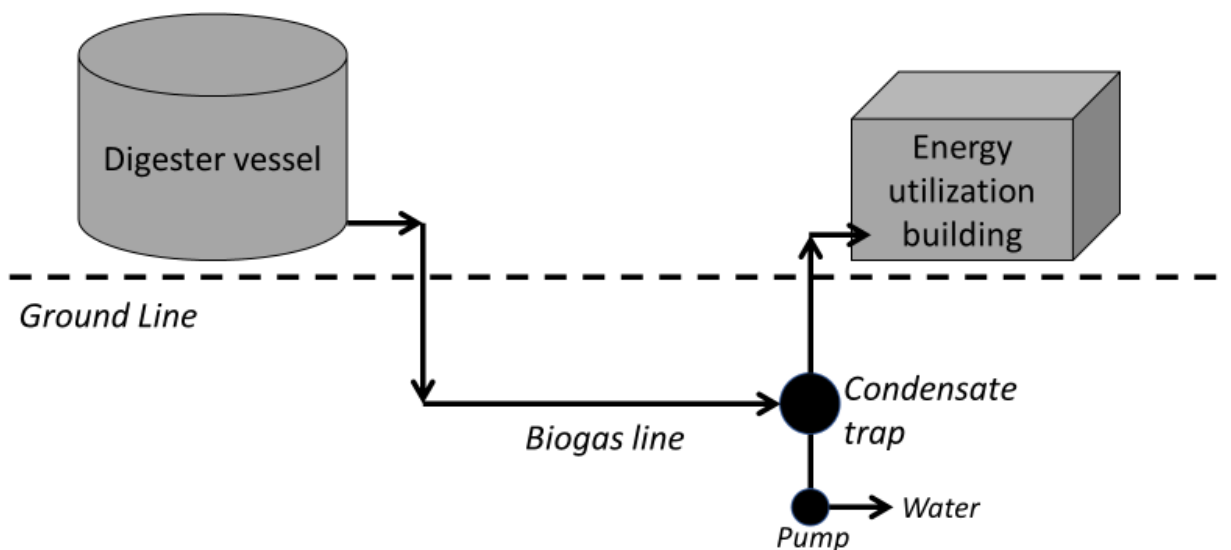

Figure 20. Using a condensate trap to passively remove moisture from biogas; Note: biogas line should be sloped towards condensate trap.

Typically, passive removal of moisture from biogas is a side benefit of running biogas piping underground. Depending on the biogas flowrate, distances of 150 feet or more are required for significant moisture removal.

A major drawback of running biogas piping underground is that it can be difficult to service/replace the piping. It is also key that a constant slope towards a condensate drain(s) be maintained. If the piping settles inconsistently, it is possible that the condensate could build up in a low spot creating blockage.

It is also important that the condensate traps be regularly emptied to prevent the buildup of water in the system; sump pumps or similar are used to pump condensate from the trap back into the liquid manure system. Pumps can either be operated manually by an on/off switch (as a part of daily maintenance) or automatically through either timer or float-controlled valves.

3.3.2 Refrigeration

Another strategy used to remove moisture (i.e., water vapor) from biogas is refrigeration. Typically, a refrigeration system is used to cool ethylene glycol, which is then circulated through a heat exchanger to cool the biogas below the dew point (~52°F, but depends on the moisture content of the biogas, which in this case is assumed to be saturated with water). The condensate is removed from the system and can be added to the digester effluent stream. Cooling the biogas from 100°F (the typical temperature of gas from an anaerobic digester) to below the dew point can remove up to 75% of the WV.

Though highly effective at removing moisture from biogas, the process is energy intensive, which may or may not be a major concern depending on whether a system produces surplus electricity and the value received for it. The electricity use and volume of condensate produced as a function of farm size (biogas production) is shown in Table 10.

The process of refrigeration to remove moisture from biogas is relatively simple, and once installed requires only periodic maintenance to ensure proper condenser operation and that there is no fouling or blocking of the heat exchanger(s). There are no chemicals or reagents consumed in the process.

Table 10. Condenser electricity use and volume of condensate produced as a function of farm size and AD influent (biogas production)¹.

Farm size (LCE²)	AD influent	Biogas production (CF/day)	Electricity use (kWh/yr)	Condensate volume (gal/yr)
100	Manure only	7,900	4,669	748
100	+10% Whey	8,690	5,135	822
100	+10% FOG	12,874	7,601	1,218
250	Manure only	19,750	11,645	1,869
250	+10% Whey	21,725	12,804	2,056
250	+10% FOG	32,185	18,929	3,046
500	Manure only	39,500	23,197	3,738
500	+10% Whey	43,450	25,496	4,112
500	+10% FOG	64,370	37,614	6,091
1,000	Manure only	79,000	46,028	7,476
1,000	+10% Whey	86,900	50,551	8,223
1,000	+10% FOG	128,741	74,271	12,183
1,500	Manure only	118,500	68,502	11,214
1,500	+10% Whey	130,350	75,176	12,335
1,500	+10% FOG	193,111	110,008	18,274
2,000	Manure only	158,000	90,627	14,952
2,000	+10% Whey	173,800	99,381	16,447
2,000	+10% FOG	257,481	144,858	24,366
2,500	Manure only	197,500	112,412	18,690
2,500	+10% Whey	217,250	123,179	20,559
2,500	+10% FOG	321,852	178,854	30,457
3,000	Manure only	237,000	133,863	22,428
3,000	+10% Whey	260,700	146,578	24,670
3,000	+10% FOG	386,222	212,027	36,549
4,000	Manure only	316,000	175,798	29,904
4,000	+10% Whey	347,600	192,220	32,894
4,000	+10% FOG	514,963	276,022	48,732

¹Assuming biogas is saturated, has a dew point of 52°F and a biogas temperature of 100°F

²Lactating cow equivalent

3.3.3 Desiccants

Another strategy to remove moisture from biogas is adsorption by using desiccants. A desiccant is a salt-based material, usually in the form of silica or alumina. Adsorption agents are used to capture moisture in the biogas. Silica gel or aluminum oxide are used when biogas is destined to be used as a vehicle fuel. The desiccant is held in a sealed, gas tight vessel, through which the

biogas flows. The desiccant reacts with the biogas and forms a liquid that is drained out of the vessel by gravity. The desiccant is dissolved during the process, and therefore, desiccant levels must be monitored to determine when the desiccant has been consumed. Often, two vessels are used, similar to when biogas is treated with an iron sponge, to provide continuous treatment opportunities.

3.4 Carbon dioxide removal

Carbon dioxide is one contaminant that must be removed for uses of biogas such as pipeline injection and use as a vehicle fuel.

A comparison of four different technologies used to remove CO₂ and other contaminants from biogas is shown in Table 11. Each of these technologies are individually discussed in the sections below.

Table 11. Advanced biogas clean-up strategies comparison chart (Pronto et. al. 2014, Wellinger et al., 2013).

	Regenerative water wash	Amine scrubbing	Pressure swing adsorption	Membrane separation
Energy use (kWh/ft³)	0.3	0.67	0.27	N/A
Biomethane recovery	98.5%	99%	83-99%	90%
H₂S co-removal	Yes	Possible, but increases regeneration energy demand	Possible, but reduces process efficiency	Possible, but may decrease membrane life
Liquid H₂O co-removal	Yes	Yes	Possible, but reduces process efficiency	No
H₂O vapor co-removal	No	Yes	Yes	Possible, but may decrease membrane life
N₂ and O₂ co-removal	No	No; O ₂ degrades amine solvent	Possible	Partial

3.4.1 Regenerative water wash

Regenerative water wash is based on the principle that carbon dioxide is more dissolvable in pressurized water than methane. Counter flow technology uses an adsorption scrubber which

contains media to increase the surface area between biogas and water. It is important to remove H₂S (which is also soluble in water) prior to the regenerative water wash system since it will foul pipes used to convey biogas. Cleaned biogas is harvested from the top of the pressure vessel and CO₂ and dissolved methane are removed from wash water in a flash tank where water pressure is reduced. One consideration is that the wash water system can result in more WV in the processed biogas than in the raw biogas; thus, an additional moisture removal system may be warranted. This method uses approximately 6.2 kWh per ft³ of cleaned gas and is 98-99 percent efficient in CH₄ capture (Carbotech, 2008).

3.4.2 Regenerative amine wash

The regenerative amine wash is similar to the regenerative water wash system, but alkylamines such as diethanolamine (DEA), monoethanolamine (MEA), and methyldiethanolamine (MDEA) (referred to together as Amine) are used to adsorb CO₂. Amine chemicals are very effective at CO₂ removal, resulting in almost pure biomethane and little loss in tail gas. However, moisture in biogas can dilute the amine chemicals, thereby reducing efficiency. Some drawbacks to this process are the fact that amine chemicals are corrosive, toxic to humans and the environment, and the process is high in parasitic power needed for regeneration of the amine solution. The generated waste is considered hazardous and should be disposed of properly. Material Safety Datasheets for MEA state that the waste chemical should be carefully placed in sealed containers, neutralized to around pH 7, and disposed as hazardous waste following local regulations at approved waste disposal plants. A process flow diagram example is shown in Figure 21.

back in the main gas stream so that the CH₄ still present can be recovered. At the same time, the pressure is reduced from atmospheric (15 psi) down to approximately 1 psi, or to a slight vacuum, in the third column. At this point, the gas evacuated from the third column is mostly CO₂ and other contaminant gases, along with some residual CH₄ (10 to 20% by volume). The waste gas, called tail gas, is usually either combusted (to destroy residual CH₄) or vented to the atmosphere.

PSA technology does not use any process water, produces no waste products, and uses no chemicals; it is also efficient, resulting in 97% CH₄ capture (Pronto et. al. 2014). The system components used in PSA technology are all “off-the-shelf” components and the overall system requires very low maintenance once in place. An example of a process flow diagram is shown in Figure 22.

A

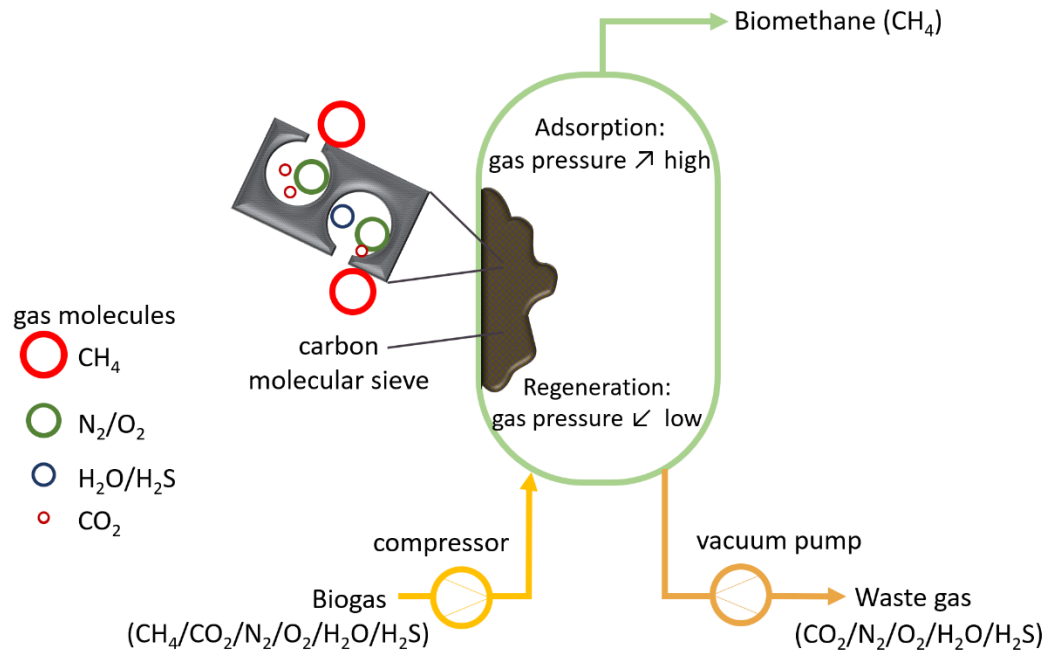

B

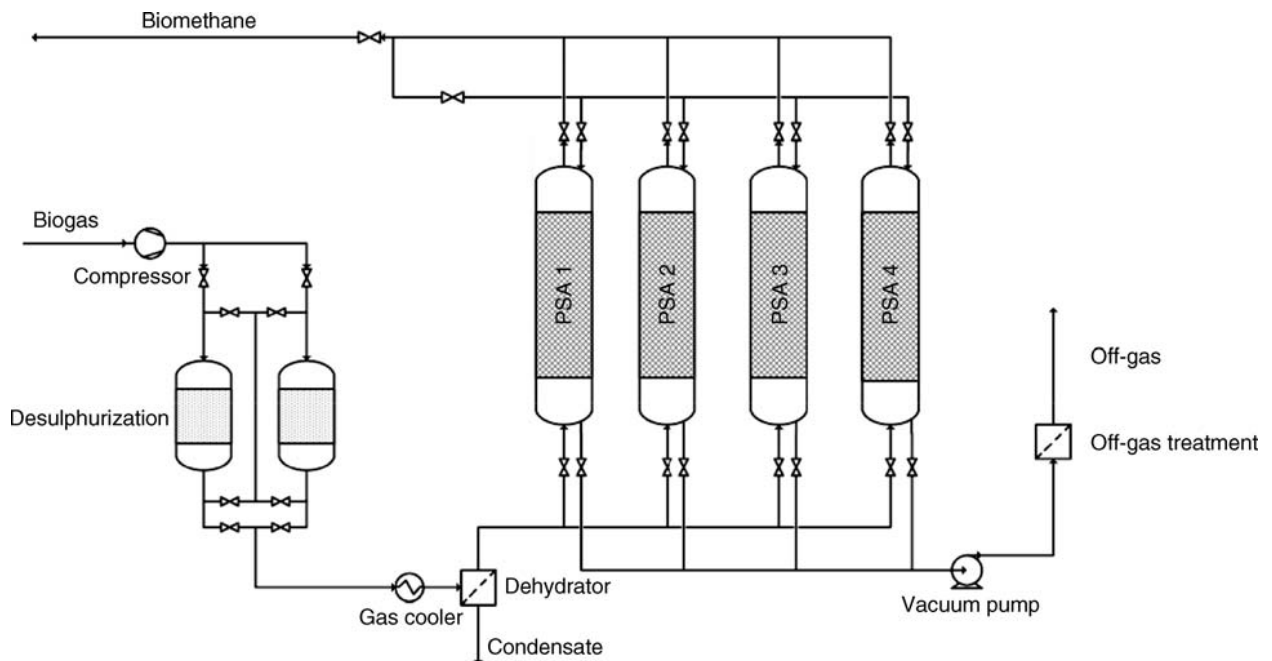

Figure 22. Pressure swing adsorption (PSA) process flow diagram example (A), adapted from Carbotech, 2008 and four PSA columns connected in parallel (B), adapted from Wellinger et al., (2013).

PSA is capable of producing a biogas that has very low water content and is cleaner than that produced by other technologies. However, the system requires sophisticated and precise control to manage the multiple vessels and gas recycling (without which CH₄ losses are significantly increased). Contaminants in the biogas, such as any particulate matter, can result in fouling of the columns and reduced system function. The adsorbent material typically has a lifetime of 4,000 to 8,000 hours, but can be extended with lower concentrations of H₂S, and therefore, pretreatment to remove H₂S is usually recommended, especially with biogas containing high H₂S concentrations. The annual electricity use of variously sized pressure swing adsorption biogas treatment systems as a function of farm size (biogas production) is shown in Table 12. It should be noted that the energy use is highly dependent on the sizing of the system, the particular technology used by the specific vendor (variable speed pumps, etc.), and the sophistication of the gas recovery and regeneration processes. The table values are based on a single value of 0.25 kWh of electricity to treat 35 cubic feet of biogas (Pronto et al., 2014).

Table 12. Estimated¹ annual electricity use of pressure swing adsorption (PSA) biogas treatment systems as a function of farm size and AD influent (biogas production).

Farm size (LCE²)	AD influent	Biogas production (CF/day)	Electricity use (kWh/yr)
100	Manure only	7,900	20,413
100	+10% Whey	8,690	22,454
100	+10% FOG	12,874	33,265
250	Manure only	19,750	51,032
250	+10% Whey	21,725	56,135
250	+10% FOG	32,185	83,163
500	Manure only	39,500	102,065
500	+10% Whey	43,450	112,271
500	+10% FOG	64,370	166,326
1,000	Manure only	79,000	204,129
1,000	+10% Whey	86,900	224,542
1,000	+10% FOG	128,741	332,655
1,500	Manure only	118,500	306,194
1,500	+10% Whey	130,350	336,813
1,500	+10% FOG	193,111	498,982
2,000	Manure only	158,000	408,258
2,000	+10% Whey	173,800	449,084
2,000	+10% FOG	257,481	665,308
2,500	Manure only	197,500	510,323
2,500	+10% Whey	217,250	561,355
2,500	+10% FOG	321,852	831,637
3,000	Manure only	237,000	612,387
3,000	+10% Whey	260,700	673,626
3,000	+10% FOG	386,222	997,964
4,000	Manure only	316,000	816,516
4,000	+10% Whey	347,600	898,168
4,000	+10% FOG	514,963	1,330,619

¹Biogas production was calculated assuming 79 cf per LCE per day, with adjustments for co-digestion. The electricity use was based on 0.25 kWh per 35 ft³ biogas.

²Lactating cow equivalent

3.4.4 Membrane separation

Membrane separation is a process used to separate unwanted components in biogas. These components separate due to different permeation rates in a select membrane. Carbon dioxide and

H₂S follow the permeate (the unwanted components, CO₂-rich gas), while the gas that is retained is approximately 94% CH₄ (can vary from 85 - 99%). Typical operating pressure ranges between 235 and 588 psi, making this a highly parasitic operation due to the energy needs in the process.

The polymer membranes used for this process are typically produced with cellulose acetate and aromatic polyamides. These membranes are permeable for biogas contaminants, such as CO₂, H₂S, NH₃, and water vapor while retaining CH₄. However, these membranes are not as selective for N₂ and O₂, but current advances in technology have shown enhanced selectivity of O₂ (Wellinger et al., 2013).

The membranes allow for CO₂ to pass while most of the CH₄ is retained. Current applications use require the use of a two-stage systems so that any CH₄ that is not captured in the first stage can be captured in the second stage. The permeate gas can also be recycled through the first stage if a two-stage system is not available. Higher CH₄ yields with multiple stages or recirculation are possible but may lead to additional electricity consumption. Membrane separation is still not considered a mature technology and can be expensive to operate and maintain.

4 Biogas Utilization

4.1 Introduction

This chapter will discuss how biogas can be used, both on-farm and off, and concludes with a section to assist in selecting the most appropriate technology for particular situations. The usage options discussed include:

- **Combined heat and power (CHP):** this includes reciprocating internal combustion engines (the most common use of biogas in the Northeast U.S.) and microturbines coupled with combustion heat recovery systems. Electrical energy produced is used on-farm and surplus is exported to the utility grid, while recovered heat is used first to meet digester heat demand and the excess is either beneficially used when possible (e.g. space heating, water heating) or dissipated to the environment with a heat dump radiator.
- **Boiler:** Directly combusting the biogas to generate heat for use on-farm
- **Pipeline cleanup:** Cleaning up the biogas so that it is comparable to natural gas in terms of contamination levels, so that it can be injected into a pipeline for export.
- **Transportation Fuel:** Cleaning up the biogas so that it can be compressed and used to power trucks and other equipment on and off-farm.
- **Flare:** Directly combusting excess biogas to safely dispose of it.

Sterling engines along with fuel cells have been investigated, but are not being utilized, and therefore will not be discussed in this document.

4.2 Combined heat and power

4.2.1 Reciprocating internal combustion engine

There are four major components of the CHP system: the engine, the generator, the controls, and heat recovery, as shown in Figure 23. The following discussion is a summary of the important features to be considered for each of these components.

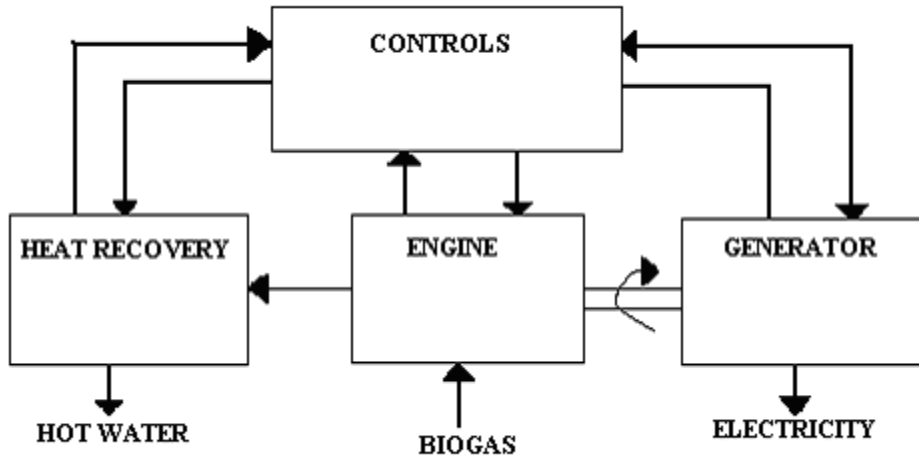

Figure 23. Four components of a combined heat and power system (Source: Cornell ABEN 458, out of print).

In addition to the EGS, other possible components of a CHP system include:

- Biogas blower: To boost the pressure and gas flow rate to the engine
- Exhaust heat exchanger: To recover exhaust heat
- Engine water jacket heat exchanger: To recover engine coolant heat
- Corrosion-proof piping & handling equipment: Pipe, meters, flame arresters, moisture traps, valves, pressure relief valves, etc.
- Utility grid interconnect controls: To automate the interconnection and protect the generator and grid
- External radiator: To dump excess water jacket heat
- Instrumentation and controls: To monitor performance and for emergency shutdown
- Flare: To burn excess biogas
- Gas scrubber: To reduce concentration of H₂S from the biogas
- Condenser: To reduce biogas moisture concentration

The most common type of EGS has been the internal combustion engine. Due to combustion characteristics, spark ignition engines are recommended over compression ignition. Other factors that should be considered in engine selection are compression ratios and spark timing. Only

industrial units designed for prime applications (when the farm intends to generate its own energy using little or no energy from the grid) should be considered, and then selected based upon the prime rating¹. In addition to capital cost, the selection of the co-generation unit should always consider efficiency (converting biogas to electricity), ease of performing maintenance tasks, and availability of parts and services.

It is advisable to seek a supplier for the EGS who has experience with biogas. Unique properties of biogas that require equipment to be set up differently than landfill gas EGS include:

- lower energy content than natural gas or propane;
- significant levels of H₂S; and
- high levels of water vapor.

Overall, these “low Btu - dirty gas” (relative to engines designed to run on natural gas) engines work well with the exception of difficulties arising from H₂S. To date, most on-farm biogas-fueled engines resist the corrosiveness by continuously operating to keep the engine running at high temperatures, and also by more frequent oil changes than for cleaner fuel source scenarios.

The EGS will operate in excess of 8,000 hours each year (equivalent to about 400,000 miles on an auto engine), thus, durability of the system is essential. Around-the-clock operation requires a well-planned and maintained control package.

Selecting the proper size of engine-generator set

For grid connected systems (where export of surplus electricity is permitted), EGS sizing is based upon the expected rate of biogas production. For the rare case of an isolated system (no utility service), EGS sizing is based upon the maximum expected farm demand. When isolated, the engine will at times be operating at low output, thus requiring excess gas to be flared. The expected size of EGS and annual electricity production based on farm size (biogas flow) and engine efficiency is shown in Table 13.

¹ Prime rating: Prime power ratings can be defined as having an “unlimited run time” or essentially a generator that will be used as a primary power source. The rating is essentially the power output of a generator based on the horsepower of the engine.

Table 13. EGS size and annual electricity production as a function of farm size, AD influent (biogas flow) and EGS efficiency¹. Note: the availability of EGS are limited – check with manufacturers to determine the best available unit based on biogas volume produced and methane content.

Farm size (LCE ²)	AD influent	Biogas flow rate (CFM ³)	Engine-generator set efficiency							
			0.25		0.30		0.35		0.40	
			Capacity (kW)	Annual production (kWh/yr)	Capacity (kW)	Annual production (kWh/yr)	Capacity (kW)	Annual production (kWh/yr)	Capacity (kW)	Annual production (kWh/yr)
100	Manure only	5	14	107,615	16	129,138	19	150,661	22	172,184
100	+10 % Whey	6	16	129,138	20	154,965	23	180,793	26	206,621
100	+10 % FOG	9	25	193,707	29	232,448	34	271,190	39	309,931
250	Manure only	14	38	301,322	46	361,586	54	421,850	61	482,115
250	+10 % Whey	15	41	322,845	49	387,414	57	451,983	66	516,552
250	+10 % FOG	22	60	473,506	72	568,207	84	662,908	96	757,609
500	Manure only	27	74	581,120	88	697,345	103	813,569	118	929,793
500	+10 % Whey	30	82	645,689	98	774,827	115	903,965	131	1,033,103
500	+10 % FOG	45	123	968,534	147	1,162,241	172	1,355,948	197	1,549,655
1,000	Manure only	55	150	1,183,764	180	1,420,517	210	1,657,270	240	1,894,022
1,000	+10 % Whey	60	164	1,291,379	197	1,549,655	229	1,807,930	262	2,066,206
1,000	+10 % FOG	89	243	1,915,545	292	2,298,654	340	2,681,763	389	3,064,873
1,500	Manure only	82	224	1,764,884	269	2,117,861	313	2,470,838	358	2,823,815
1,500	+10 % Whey	91	248	1,958,591	298	2,350,310	348	2,742,028	397	3,133,746
1,500	+10 % FOG	134	366	2,884,079	439	3,460,895	512	4,037,711	585	4,614,527
2,000	Manure only	110	300	2,367,528	360	2,841,034	420	3,314,539	480	3,788,045
2,000	+10 % Whey	121	330	2,604,281	396	3,125,137	462	3,645,993	529	4,166,849
2,000	+10 % FOG	179	489	3,852,614	586	4,623,136	684	5,393,659	782	6,164,182
2,500	Manure only	137	374	2,948,648	449	3,538,378	524	4,128,108	598	4,717,837
2,500	+10 % Whey	151	412	3,249,970	495	3,899,964	577	4,549,958	660	5,199,952
2,500	+10 % FOG	224	612	4,821,148	734	5,785,377	856	6,749,607	978	7,713,836
3,000	Manure only	165	450	3,551,292	541	4,261,550	631	4,971,809	721	5,682,067
3,000	+10 % Whey	181	494	3,895,660	593	4,674,791	692	5,453,923	791	6,233,055
3,000	+10 % FOG	268	732	5,768,159	878	6,921,791	1024	8,075,423	1171	9,229,054
4,000	Manure only	219	598	4,713,533	717	5,656,239	837	6,598,946	957	7,541,653
4,000	+10 % Whey	241	658	5,187,038	790	6,224,446	921	7,261,854	1053	8,299,262
4,000	+10 % FOG	358	977	7,705,227	1173	9,246,273	1368	10,787,318	1564	12,328,364

¹Assuming a biogas heating value of 621 Btu/ft³, and a capacity factor of 0.9

²Lactating cow equivalent

³cubic feet per minute

For the most common configuration, generating when connected to the grid, the EGS should be sized based on not exceeding the biogas supply. It is preferable to size the unit slightly smaller than the gas supply will support, if possible, so that the engine can be operated continuously and at full capacity. Over-sizing will result in greater initial capital cost, lower system operating efficiency in converting total biogas to electricity, and higher maintenance costs per unit of energy generated.

For continuously operated EGS, initial sizing can be done by using one kilowatt (kW) of co-generator capacity per 6 LCE (based on 79 ft³ biogas/cow-day and 30% engine efficiency). If potential gas production has been estimated (when co-digestion is planned), the EGS should have one kilowatt of capacity per 600-650 ft³ of daily biogas production. For example, for a 250-cow dairy with a digester producing 19,750 ft³ of biogas per day, a 40-kilowatt generator (based on 30% efficiency) is suggested.

Historically, EGS operated on raw biogas. Excessive wear of the engine was controlled by frequent oil changes, and this practice continues today to some degree. However, some EGS manufacturers now have warranty restrictions when raw biogas is used, thus, encouraging EGS users to reduce the biogas H₂S concentration to a target level (~500 ppm in one case) or below by employing a biogas clean-up system.

Efficient conversion of biogas to electricity will affect the total annual cost of the system. Even small reductions in efficiency have economic implications for a continuously operated EGS. To monitor operating efficiency, the system should include meters for biogas consumption by the engine and electricity production by the generator. Comparison of the data produced by these two meters provides critical information for the management of the EGS. In addition to low conversion efficiency, operation at less than 80% full load may create operational problems from accumulating exhaust gas condensation.

For the above reasons, it is difficult to size the EGS for the future if there are possibilities for business expansion at a later date. In the event that gas supplies increase due to expanded operations or the addition of food waste, options could include adding other uses for biogas,

replacing the EGS with a larger unit, or adding an additional unit. Some experts recommend sizing the EGS after digester start-up is complete, but this is rarely economically possible. One alternative is to oversize a naturally aspirated engine and later add a turbo-charge the engine in the future, if this is possible for a specific make and model. Considerations and specifications for engine, generator, controls, heat recovery and are summarized in Table 14.

Table 14. Key design specifications for EGS equipment.

Engine
Industrial engine designed for continuous, prime power applications
Gas carburetor
Naturally aspirated if available
10:1 or greater compression ratio
Generator
Synchronous generator (induction generators were formerly used, but most electronic controls now work as well for synchronous generators which may be lower cost)
80% power factor ² or greater
Prime rated
Controls
Gas pressure responsive throttle
Engine shut-down for:
- high coolant temperature
- low coolant level
- low oil pressure
- engine over speed
- generator operation discontinuance
Generator shut-down for:
- over/under voltage
- over/under frequency
- reverse current flow
- ground fault
- excess current
Heat recovery
Engine coolant heat exchanger
Exhaust gas heat exchanger (stainless steel, condensate draining)
Properly sized external radiator
Summer bypass for exhaust heat exchanger
Other
Size matched to gas production without over-sizing
Output de-rated for biogas as per manufacturer

² Power factor: the ratio between active power (power drawn by the electrical resistance of a system doing useful work) and apparent power (the voltage multiplied by the current flow). A low power factor will reduce the electrical system's distribution capacity by increasing the current flow and causing voltage drops (Engineering Toolbox, 2018).

De-rating of an engine-generator set

Since the energy values for biogas are lower than conventional fuels, some engines may need to be de-rated. This de-rating may be as much as 15% less than a rated performance as compared to propane. For other engines, de-rating may not be necessary if a sufficient input flow of biogas can be obtained. The engine supplier should be consulted to determine how to apply de-rating factors. Small changes in the efficiency of converting biogas to electricity will substantially impact the financial return of the entire biogas system.

Engine-generator set maintenance

The primary goal of EGS maintenance is to sustain constant operation 92% of the time or more (100% run time is not possible due to routine operation and maintenance procedures requiring the engine to stop running). It has been noted that successful operations of this type must have a person or persons in positions of primary responsibility who are equipment oriented and willing to devote time and attention to the electrical and mechanical details. With the engine operating regularly, only periodic maintenance intervals need to be scheduled. Good management necessitates that preventative maintenance be performed on schedule throughout the year.

The EGS supplier or system designer should supply a manual with maintenance procedure modifications necessary for the biogas application. Table 15 lists many typical maintenance procedures and approximate intervals.

Table 15. EGS maintenance items.

Item	Hours	Interval
Oil and filter change (shorter intervals initially; some systems are going to longer intervals)	300	12 days
Spark plug replacement and ignition timing	500	21 days
Air filter replacement	500	21 days
Generator lubrication	500	21 days
Check/adjust valve lash	2,000	3 months
Gas meter service	2,000-4,000	3 - 6 months
Carburetor mixture setting	4,000	6 months
Water pump bearing replacement	4,000-8,000	6 - 12 months
Engine head/valve train overhaul	4,000-8,000	6 - 12 months
Removal and cleaning of gas handling components	8,000	1 year
Coolant system flushed	8,000	1 year
Safety controls check	8,000	1 year
Major engine overhaul	8,000 - 16,000	1 - 2 years

It should be noted that maintenance operations for continuously operated, essential equipment involves scheduled replacement of key components prior to failure rather than repair after failure. Though this presents added expense for maintenance parts and time, the additional cost must be weighed against the lost revenue from prolonged downtime (and potential for digester temperature loss precipitating a downward spiral with loss of biogas production), costs of additional skilled service labor, and costs of additional demand charges from unscheduled repairs.

Oil selection, change intervals and testing

A single viscosity, high total base number (TBN) oil should be used and an oil testing program be followed from the start. The oil test results will be used to determine oil change intervals. One recommended procedure is to perform the first oil change at 50 hours and have the oil sample tested. Successive oil change periods are then lengthened by 50 hours each period until a low TBN value is returned from the oil sample analysis. The acceptable oil change period is then established as the hours of the prior interval. The interval should be adjusted as indicated by the test results from that point forward.

The testing program should include results for TBN, percent sulfur, copper, iron, silica, and other contaminants recommended by the testing lab and oil supplier. It is imperative to track changes in the oil analysis and seek advice concerning the significance of levels of various metals and trends of changes. Tables 16 and 17 below list some guidelines for interpreting oil analysis data based on the wear material or the contaminant present.

Table 16. Guidelines for interpreting EGS oil analysis data by wear material.

Wear material	Contributing component
Aluminum	Bearings, bushings and valve guides
Lead	Bearings, bushings and valve guides
Tin	Bearings, bushings and valve guides
Nickel	Valves
Iron	Valves, valve train, cylinder walls, crankshaft, camshaft, gear teeth, shafts
Aluminum	Pistons
Chromium	Pistons
Molybdenum	Rings, cylinder liners

Table 17. Guidelines for interpreting EGS oil analysis data by contaminant.

Contaminant	Potential source
Sulfur	Fuel and combustion products
Silicon	Oil antifoam agent, antifreeze
Sodium	Oil additive, coolant, environmental factors
Glycol	Antifreeze
Water	Antifreeze
Silica	Dust in air - filter failure

Generator

Most on-farm anaerobic digestion system installations today are on modern, large farms that are connected to the grid before the system is set in-place. A typical operating mode for most co-generators is continuous operation at a power output that is established by biogas production. Continuous operation produces electricity at a nearly constant rate, minimizes engine wear, and eliminates the need for biogas storage. The wide swings in farm electrical demand over a 24-hour period require parallel operation with the electric company for this typical operating mode. Depending on the on-farm electrical demand and co-generator production, some electricity will be purchased or sold to the utility. Continuous operation at a level set by biogas production is the simplest operating mode.

Overall, there are two basic types of generators:

- **Induction generators:** run off the signal from the utility and are used to allow parallel hook up with the utility. In most cases, induction generators cannot be used as a source of on-farm backup power since the system needs the signal from the utility line to operate properly.
- **Synchronous generators:** could be run independently of the utility, however, previously, matching the utility's power signal was very difficult so these types of generators were used if the system was not connected to the utility grid. Currently, electronic controls make synchronization easier.

Most generator systems manufactured today have controls that will allow the EGS to synchronize with the utility's electrical frequency and still operate in island mode when there is a disruption of the grid power. These systems can be set up to start without any electric input if desired.

Energy generation

Thermal to electrical conversion efficiencies for biogas-fueled spark ignition internal combustion EGS are less than desirable. On-farm digester monitoring has shown that the conversion efficiency ranged from 22 to 29 percent (excluding Farm AA's conversion data that is low due to an inordinately old EGS) as shown in Figure 24.

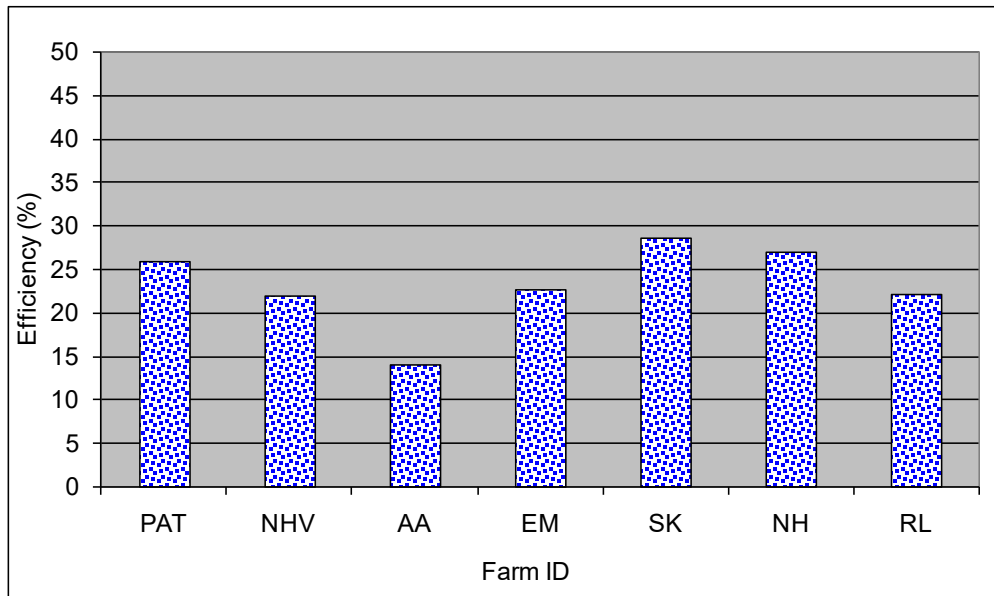

Figure 24. Thermal to electric conversion efficiency of seven NYS on-farm EGS (Pronto & Gooch, unpublished).

The electricity production depends on the amount and quality of gas as well as the efficiency of the EGS. The output from the generator in the study averaged 0.14 kW/ LCE, while the energy content of the biogas averaged 0.54 kW/LCE (Ludington and Weeks, 2008). Other sources state that 33 to 38 kWh will be produced per 1,000 ft³ biogas (Koelsch et al., undated; EPA, 1997). Operation and maintenance costs currently range from \$0.03 to \$0.035 per kWh generated (Wright, 2018).

Heat recovery

Engine water jacket heat, and sometimes exhaust heat as well, is collected and used as the primary means to heat the digester, and on some farms, secondarily to also heat domestic water and space heating. In the winter, most if not all of this collected heat is needed, while in the summer a good

portion of it is dumped to the ambient air via a fan-radiator set. The amount of heat recovered varies based predominately on thermal to electric conversion efficiency of the EGS and the specifics of the heat reclamation equipment. Commercially available heat exchangers are used for heat recovery; properly sized heat exchangers will recover about 7,000 Btu of heat per hour for each unit (kW) of generator load (Pronto et. al., 2014). For example, a CHP with a generation capacity of 200 kW will produce 1,400,000 Btu/hour ($7,000 \text{ Btu/hr-kW} \times 200 \text{ kW} = 1,400,000 \text{ Btu/hr}$). An on-farm example of a heat recovery system used in conjunction with an EGS is shown in Figure 25, with the accompanying photo of an installation in NY, in Figure 26.

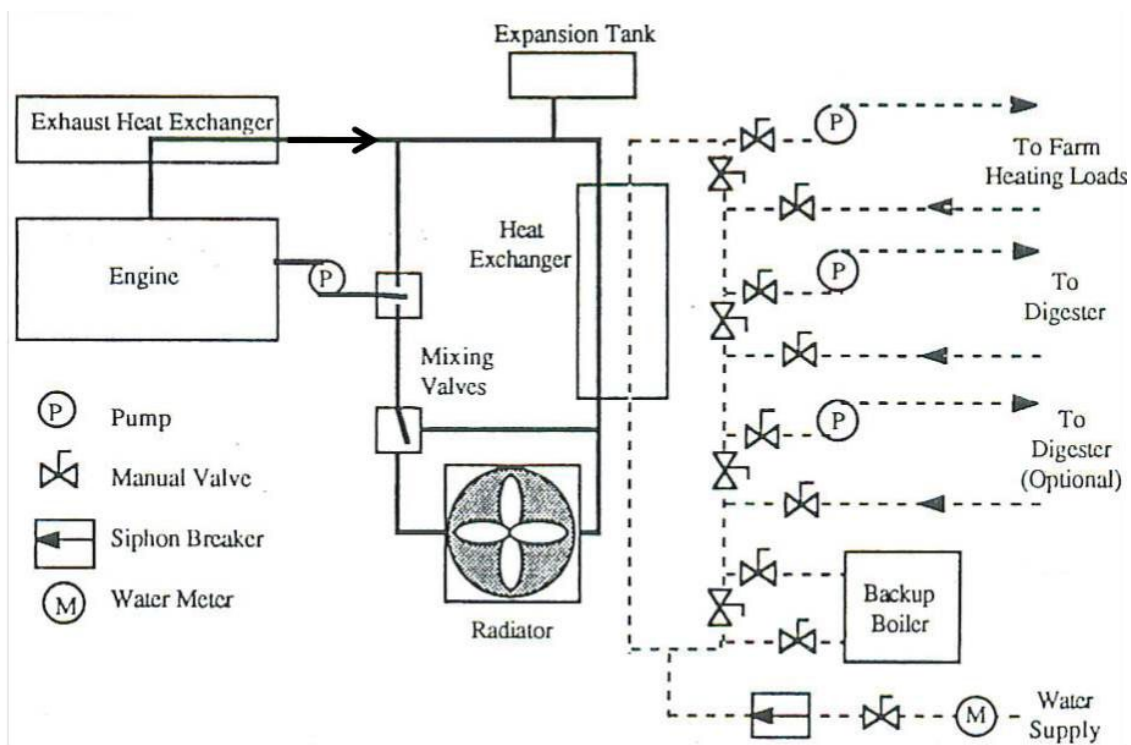

Figure 25. Layout of a heat recovery system (Source: Cornell ABEN 458, out of print).



Figure 26. Wagner Farm EGS with heat recovery system (Source: Gooch, 2009).

The heat recovery system must include a means of dumping any excess heat that is not needed for process heat or otherwise beneficial uses to the environment. A radiator and fan sized to dissipate all coolant and recovered exhaust heat (if applicable) are required. The additional heat captured from the exhaust will require a radiator that is about 50% larger than would normally be matched with an engine. For summer operation, unless exhaust heat is needed, it is desirable to bypass the exhaust heat exchanger to minimize the run time of the heat dump radiator. Table 18 presents the potential heat that could be recovered from an EGS based on farm size (biogas flow) and EGS efficiency.

Table 18. Example heat available from the engine (engine oil and engine water jacket) and engine exhaust based on farm size and AD influent (biogas flow) and EGS efficiency, and assuming typical values for heat recovery from the engine (85%) and exhaust (55%).²

Farm size (LCE ¹)	AD influent	Biogas production (CFM)	Engine-generator set efficiency							
			0.25		0.30		0.35		0.40	
			Engine (Btu/hr)	Exhaust (Btu/hr)	Engine (Btu/hr)	Exhaust (Btu/hr)	Engine (Btu/hr)	Exhaust (Btu/hr)	Engine (Btu/hr)	Exhaust (Btu/hr)
100	Manure only	5	70,430	33,361	65,734	31,137	61,039	28,913	56,344	26,689
100	+10 % Whey	6	77,473	36,698	72,308	34,251	67,143	31,805	61,978	29,358
100	+10 % FOG	9	114,774	54,367	107,123	50,742	99,471	47,118	91,820	43,493
250	Manure only	14	176,074	83,404	164,336	77,843	152,598	72,283	140,859	66,723
250	+10 % Whey	15	193,682	91,744	180,770	85,628	167,858	79,511	154,945	73,395
250	+10 % FOG	22	286,936	135,917	267,807	126,856	248,678	117,795	229,549	108,734
500	Manure only	27	352,149	166,807	328,672	155,687	305,196	144,566	281,719	133,446
500	+10 % Whey	30	387,364	183,488	361,539	171,255	335,715	159,023	309,891	146,790
500	+10 % FOG	45	573,872	271,834	535,614	253,712	497,356	235,590	459,098	217,467
1,000	Manure only	55	704,297	333,615	657,344	311,374	610,391	289,133	563,438	266,892
1,000	+10 % Whey	60	774,727	366,976	723,079	342,511	671,430	318,046	619,782	293,581
1,000	+10 % FOG	89	1,147,744	543,668	1,071,228	507,424	994,711	471,179	918,195	434,935
1,500	Manure only	82	1,056,446	500,422	986,016	467,060	915,587	433,699	845,157	400,337
1,500	+10 % Whey	91	1,162,091	550,464	1,084,618	513,766	1,007,145	477,069	929,672	440,371
1,500	+10 % FOG	134	1,721,616	815,502	1,606,841	761,135	1,492,067	706,769	1,377,293	652,402
2,000	Manure only	110	1,408,595	667,229	1,314,688	622,747	1,220,782	578,265	1,126,876	533,783
2,000	+10 % Whey	121	1,549,454	733,952	1,446,157	685,022	1,342,860	636,092	1,239,563	587,162
2,000	+10 % FOG	179	2,295,488	1,087,336	2,142,455	1,014,847	1,989,423	942,358	1,836,390	869,869
2,500	Manure only	137	1,760,743	834,036	1,643,360	778,434	1,525,978	722,831	1,408,595	667,229
2,500	+10 % Whey	151	1,936,818	917,440	1,807,697	856,277	1,678,575	795,115	1,549,454	733,952
2,500	+10 % FOG	224	2,869,360	1,359,170	2,678,069	1,268,559	2,486,778	1,177,948	2,295,488	1,087,336
3,000	Manure only	165	2,112,892	1,000,844	1,972,033	934,121	1,831,173	867,398	1,690,314	800,675
3,000	+10 % Whey	181	2,324,181	1,100,928	2,169,236	1,027,533	2,014,290	954,138	1,859,345	880,742
3,000	+10 % FOG	268	3,443,231	1,631,004	3,213,683	1,522,271	2,984,134	1,413,537	2,754,585	1,304,804
4,000	Manure only	219	2,817,189	1,334,458	2,629,377	1,245,494	2,441,564	1,156,530	2,253,752	1,067,567
4,000	+10 % Whey	241	3,098,908	1,467,904	2,892,314	1,370,044	2,685,721	1,272,183	2,479,127	1,174,323
4,000	+10 % FOG	358	4,590,975	2,174,673	4,284,910	2,029,694	3,978,845	1,884,716	3,672,780	1,739,738

¹Lactating cow equivalent

²Assuming that of the energy not converted to electricity, 55% is lost through the exhaust and 45% through the engine (water jacket and engine oil), and that radiative and conductive losses are negligible.

End use of biogas and H₂S removal

The options for biogas treatment and use vary significantly according to farm needs and system design. In the farm example shown in Figure 27 (NHV Farm, NY), raw biogas was piped to a gas utilization skid which determines where the biogas will go – either to a boiler, a microturbine, or a flare. This farm has an iron sponge H₂S reduction system used to clean the biogas before being used by a microturbine. Only the flow of biogas needed to power the microturbine was scrubbed in the iron sponge. Priority was shared between the boiler, which was used to generate heat to provide parasitic heating needs to the digester vessel, and the microturbine, which needs a requisite amount of biogas to run continuously. If the microturbine ceases to operate (or the microturbine does not provide sufficient energy to meet the farm’s needs), additional electricity must be purchased from the grid, which can be a significant cost due to an increased demand charge. The flare provides a means of combusting biogas not needed for primary uses.

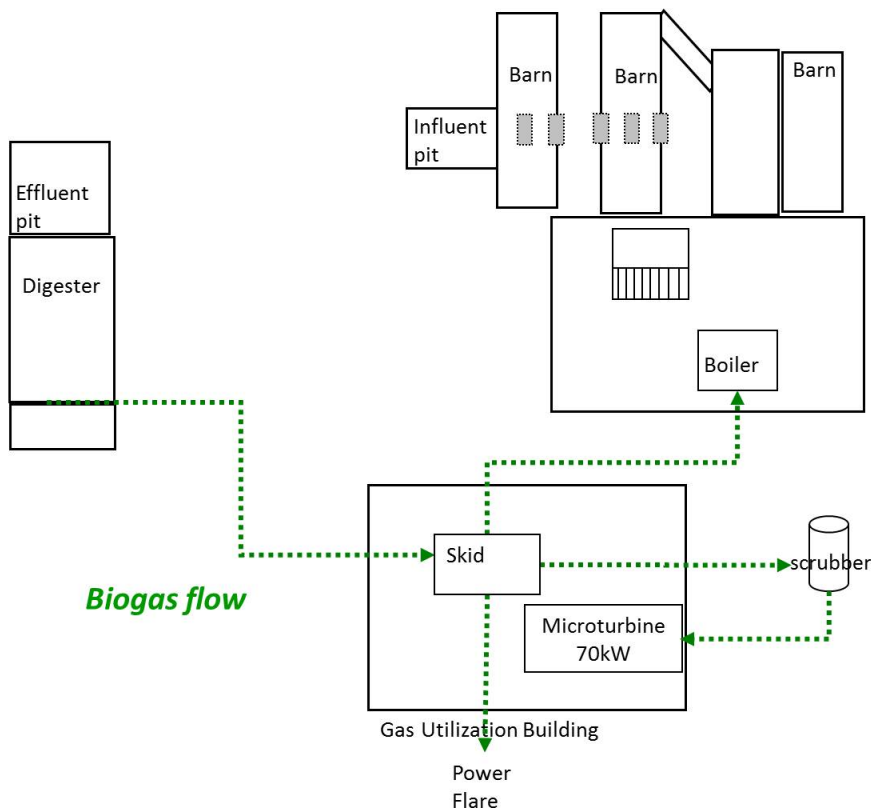

Figure 27. NHV Farm AD system and biogas flows.

The example shows that the threshold for the H₂S concentration in biogas depends on the ultimate use of the biogas and expensive scrubbers may not be necessary if the end use is heat generation using a boiler. The maximum concentration of H₂S allowable in biogas for various uses is shown in Table 19 (Electrigaz Report, 2008). Historically, certain systems (i.e., boiler and EGS) have operated at much higher concentrations than shown in this table, but likely required additional maintenance by the farm.

Table 19. Recommended maximum concentration of H₂S for various biogas end uses.

Designated biogas end use	Maximum H₂S concentration (ppm)
Boiler	1,000
Engine-generator set	500
Vehicle fuel	23
Pipeline injection	4
Fuel cell	1

The typical fuel-to-power efficiencies of various biogas utilization options are shown in Table 20. These electric efficiency figures do not account for increases due to the potential use of co-generated heat.

Table 20. Typical fuel-to-power efficiency values (adapted and updated¹ from Wright, 2001).

Prime mover type	Efficiency
Spark ignition engine	18-42%
Compression ignition engine (Diesel)	30-35% above 1 MW 25-30% below 1 MW
Gas turbine	18-40% above 10 MW
Microturbine	25-35% below 1 MW
Fuel cell	40-60%

¹updated as of 2014

The lower energy density of biogas requires the use of larger nozzles in burner units of heating appliances and engine carburetors to deliver an equal amount of energy to the point of combustion. If biogas is used in a natural gas or liquid propane gas appliance or carburetor, the restricting nozzle must be greater in diameter than a nozzle normally used with natural gas. The slow burning nature of biogas also requires that spark timing be advanced to obtain maximum power.

4.2.2 Microturbine

Gas microturbines are a technology that is used in numerous distributed generation installations. They are smaller versions of the large industrial turbine generators that have been in service for many years operating on conventional fuel gasses. Several manufacturers offer microturbine units in sizes from 30 kW to over 250 kW. The advantages of microturbine generators include mechanical simplicity, quiet operation, capability of computerized remote operation, and small size. Disadvantages include the requirement to compress the biogas and scrubbing H₂S to trace levels or using corrosion resistant compressors.

For farm biogas applications, the microturbine generator requires a compressor and a gas scrubber/conditioner. The turbine requires a fuel gas input pressure of 60 psi; but can vary by the manufacturer. Small-scale compressors are available to compress raw biogas to this pressure. The fuel gas must also be conditioned to tolerable limits of water vapor and other contaminants with the scrubber/conditioner. The tolerable limit specifically for H₂S in an Ingersoll-Rand microturbine formerly operated on a NYS dairy-based AD system was approximately 50 ppm. Capstone microturbines, on the other hand, can tolerate H₂S concentrations up to 5,000 ppm and 70,000 ppm, depending on the model. Generally, microturbines are more resistant to sulfur contaminants in comparison to gas engines (Wellinger et al., 2013). Units can be installed in series and operated automatically to respond to varying loads or fuel gas supply. Microturbines are supplied with integrated exhaust heat exchangers for combined heat and power applications. Microturbines are less efficient at converting biogas thermal energy to electricity than most EGS, converting a higher percentage of input fuel to thermal energy and exhaust heat. When comparing microturbines to EGS, the cost and maintenance of fuel conditioning and compressing equipment must be considered as well as the energy overhead to operate the compressor.

Two NYS dairy farms formerly had microturbines installed to convert biogas to electricity. The main interest in microturbines was the premise that they required less maintenance on a daily and on a long-term basis, and most recently that they potentially produced less exhaust emissions due to high operating temperatures. Operator experience revealed that challenges existed with operating the microturbines due to biogas quality impacts on compression equipment and therefore they were removed and replaced with EGS systems.

4.3 Boiler

On-farm biogas utilization by a boiler is the second most popular use of the energy produced. Natural gas boilers can be slightly modified to run on biogas. The main modification involves increasing the pipe delivery size and orifices in the burners to accommodate the lower density fuel. Boilers are mainly used to provide primary or secondary heating of the digester and in some cases also to provide domestic heating of farm offices and lounge areas. One farm used boiler heat to heat a calf barn, but this use is limited. The heat available from a boiler as a function of farm size (biogas flow) and boiler efficiency is shown in Table 21.

Table 21. Heat production (Btu/hr) of biogas boilers based on farm size and AD influent (biogas flow) and boiler efficiency.

Farm size (LCE ¹)	AD influent	Biogas production (CFM)	Boiler efficiency (%)			
			0.75	0.80	0.85	0.90
100	Manure only	5	134,794	143,780	152,766	161,753
100	+10 % Whey	6	148,273	158,158	168,043	177,928
100	+10 % FOG	9	219,664	234,308	248,952	263,597
250	Manure only	14	336,984	359,450	381,916	404,381
250	+10 % Whey	15	370,683	395,395	420,107	444,819
250	+10 % FOG	22	549,160	585,770	622,381	658,992
500	Manure only	27	673,969	718,900	763,831	808,763
500	+10 % Whey	30	741,366	790,790	840,214	889,639
500	+10 % FOG	45	1,098,319	1,171,541	1,244,762	1,317,983
1,000	Manure only	55	1,347,938	1,437,800	1,527,663	1,617,525
1,000	+10 % Whey	60	1,482,731	1,581,580	1,680,429	1,779,278
1,000	+10 % FOG	89	2,196,639	2,343,081	2,489,524	2,635,967
1,500	Manure only	82	2,021,906	2,156,700	2,291,494	2,426,288
1,500	+10 % Whey	91	2,224,097	2,372,370	2,520,643	2,668,916
1,500	+10 % FOG	134	3,294,958	3,514,622	3,734,286	3,953,950
2,000	Manure only	110	2,695,875	2,875,600	3,055,325	3,235,050
2,000	+10 % Whey	121	2,965,463	3,163,160	3,360,858	3,558,555
2,000	+10 % FOG	179	4,393,278	4,686,163	4,979,048	5,271,933
2,500	Manure only	137	3,369,844	3,594,500	3,819,156	4,043,813
2,500	+10 % Whey	151	3,706,828	3,953,950	4,201,072	4,448,194
2,500	+10 % FOG	224	5,491,597	5,857,704	6,223,810	6,589,917
3,000	Manure only	165	4,043,813	4,313,400	4,582,988	4,852,575
3,000	+10 % Whey	181	4,448,194	4,744,740	5,041,286	5,337,833
3,000	+10 % FOG	268	6,589,917	7,029,244	7,468,572	7,907,900
4,000	Manure only	219	5,391,750	5,751,200	6,110,650	6,470,100
4,000	+10 % Whey	241	5,930,925	6,326,320	6,721,715	7,117,110
4,000	+10 % FOG	358	8,786,556	9,372,326	9,958,096	10,543,867

¹Lactating cow equivalent

4.4 Transport fuel

Dairy manure-based RNG/biomethane, can be used in alternative fuel vehicles employing natural gas as a fuel, as it is fully interchangeable with conventional natural gas. Biogas refined to RNG for vehicle use undergoes a process that removes WV, CO₂, H₂S, and other trace elements. The resulting RNG has a higher CH₄ content than raw biogas, which makes it virtually equivalent to conventional natural gas and thus a suitable energy source in applications that require pipeline-

quality gas. Like conventional natural gas, RNG can be used as a transportation fuel as it can be virtually identical to compressed natural gas (CNG) or liquid natural gas (LNG). RNG qualifies as an advanced biofuel under the Renewable Fuel Standard (AFDC, 2017). Hilarides Dairy in California and Prairie's Edge Dairy in Indiana are using RNG to produce transportation fuel and power their milk delivery truck fleets (Pronto, 2017).

Prairie's Edge Dairy Farm uses an on-farm anaerobic digester to produce biogas, which is then refined to RNG, and piped to one of two CNG filling stations in the area. The farm and its' associated trucking company partnered with the Indiana "Clean Cities" coalition and used Federal Recovery and Reinvestment Act (2009) funding to increase the alternative fuel usage in the state. Other goals of the project were to reduce trucking fuel costs and similarly, to reduce trucking-related GHG emissions from the standard use of diesel fuel. The trucking company committed to the project by converting the entire 42-truck fleet of semi-tractors to run on CNG, in turn creating one of the largest fleets of Class 8 trucks run on natural gas (US DOE, 2013). The dairy products produced by the farm are distributed to various points-of-sale across the country; all with the use of the RNG powered trucking fleet.

5 References

- ABEN Bulletin 458. 1992. Department of Agricultural and Biological Engineering, Cornell University, Ithaca, NY.
- Al Seadi, T., Rutz, D., Prassl, H., Köttner, M., Finsterwalder, T., Volk, S. and Janssen, R., 2008. *Biogas Handbook – University of Southern Denmark Esbjerg*. ISBN 978-87-992962-0-0.
- Aldrich, B.S., Brown, N.J., Hallman, E.M. 2005. *Manure Gas can be Deadly*. NorthEast Dairy Business.
- Alternative Fuels Data Center (AFDC). 2017. *Renewable Natural Gas (Biomethane) Production*. Website: https://www.afdc.energy.gov/fuels/natural_gas_renewable.html
- Angenent, L. 2009. Associate Professor of Biological and Environmental Engineering, Cornell University. Personal Communication.
- ASABE. 2005. *Manure Production and Characteristics*. ASAE D384.2 MAR2005
- Bothi, K. 2007. *Characterization of Biogas from Anaerobically Digested Dairy Waste for Energy Use*. Ithaca, NY: Cornell University.
- Carbotech, 2008. Personal Communication.
- Crawford, G.I. 2007. *Managing Sulfur Concentrations in Feed and Water*. University of Minnesota Extension.
- Díaz, I. and Fdz-Polanco, M. 2012. “Robustness of the microaerobic removal of hydrogen sulfide from biogas.” *Water Science and Technology*, 65(8), pp.1368-1374.
- Electrigaz Technologies, Inc., 2008. “*Feasibility Study – Biogas upgrading and grid injection in the Fraser Valley, British Columbia*” Prepared for the BC Innovation Council.
- Engineering Toolbox. November 14, 2018. Website: https://www.engineeringtoolbox.com/power-factor-electrical-motor-d_654.html
- EPA. 1997. "A Manual for Developing Biogas Systems at Commercial Farms in the United States" U.S. Environmental Protection Agency. EPA-430-B-97-015.
- Gerardi, M.H., 2003. *The microbiology of anaerobic digesters*. John Wiley & Sons.
- Gooch, C.A., J. Pronto, R. Labatut. 2011. *Evaluation of Seven On-Farm Anaerobic Digestion Systems Based on the ASERTTI Monitoring Protocol: Consolidated Report and Findings*. NYSERDA PROJECT NO. 6597

- Gooch, C.A., J.L. Pronto, B. Gloy, N.R. Scott, S. McGlynn, and C. Bentley. 2010. “*Feasibility Study of Anaerobic Digestion and Biogas Utilization Options for the Proposed Lewis County Community Digester*”. Final project report submitted to Cornell Cooperative Extension of Lewis County. Available at: www.manuremanagement.cornell.edu.
- Hoffmann, R.A., Garcia, M.L., Veskivar, M., Karim, K., Al-Dahhan, M.H., Angenent, L.T. 2008. “Effect of shear on performance and microbial ecology of continuously stirred anaerobic digesters treating animal manure.” *Biotechnol and Bioeng* 100, 38-48.
- IPCC 2006, 2006 IPCC Guidelines for National Greenhouse Gas Inventories, Prepared by the National Greenhouse Gas Inventories Programme, Eggleston H.S., Buendia L., Miwa K., Ngara T. and Tanabe K. (eds). Published: IGES, Japan.
- Jewell, William. 2007. Professor Emeritus of Biological and Environmental Engineering, Cornell University. Personal Communication.
- Khanal, S.K., 2011. *Anaerobic biotechnology for bioenergy production: principles and applications*. John Wiley & Sons.
- Kim, M., Ahn, Y.H. and Speece, R.E., 2002. “Comparative process stability and efficiency of anaerobic digestion; mesophilic vs. thermophilic.” *Water research*, 36(17), pp.4369-4385.
- Koelsch, R.K., E.E. Fabian, R.W. Guest, J.K. Campbell. Undated. *Anaerobic Digesters for Dairy Farms*. Agricultural and Biological Engineering Extension Bulletin 458. Cornell University, Ithaca, NY 14853.
- Labatut, R.A., Angenent, L.T. and Scott, N.R., 2011. “Biochemical methane potential and biodegradability of complex organic substrates.” *Bioresource technology*, 102(3), pp.2255-2264.
- Labatut, R.A. and C.A. Gooch. 2014. Anaerobic Digestion System Monitoring for the Synergy Biogas, LLC Biogas Plant – Final Report. Cornell Agreement No. 65961. Available at: www.manuremanagement.cornell.edu.
- Labatut, R.A., Angenent, L.T. and Scott, N.R., 2014. “Conventional mesophilic vs. thermophilic anaerobic digestion: a trade-off between performance and stability?” *Water research*, 53, pp.249-258.
- Labatut, R.A. and J.L. Pronto. 2018. Chapter 4 – Sustainable Waste-to-Energy Technologies: Anaerobic Digestion. Sustainable Food Waste-to-Energy Systems. T.A. Trabold and C.W. Babbitt, Academic Press: 47-67.
- Ludington, D.C and S. Weeks. 2008. “The Characterization of Sulfur Flows in Farm Digesters at Eight Farms”. Project report for the New York State Energy Research and Development Authority under Project agreement 9443-1.

- Marks, L.S. 1978. *Mechanical Engineers' Handbook*, 8th Ed. McGraw-Hill Book Company, Inc.
- Moody, L.B., Burns, R.T., Bishop, G., Sell, S.T. and Spajic, R. (2011). Using Biochemical Methane Potential Assays to Aid in Co-Substrate Selection for Co-Digestion. *Applied Engineering in Agriculture* 27: 433-439
- Mulbry, W., Lansing, S., Selmer, K., 2017. "Effect of liquid surface area on hydrogen sulfide oxidation during micro-aeration in dairy manure digesters." *PLoS One* 12(10): e0185738.
- Muñoz R., Meier L., Diaz I., Jeison D. 2015. "A review on the state-of-the-art of physical/chemical and biological technologies for biogas upgrading." *Reviews in Environmental Science and Bio/Technology*. 14: 727-59.
- NYSERDA. 2012. "Assessment of Biochemical Process Controls for Reduction of Hydrogen Sulfide Concentrations in Biogas from Farm Digesters". Final Report No. 12-20.
- Oliver, J. and C. Gooch. 2016. *Hydrogen Sulfide Removal from Biogas – Part 2B: Biotrickling filters for H₂S – Overview of Configuration and Design*. Fact Sheet. Cornell PRO-Dairy Dairy Environmental Systems Program, Cornell University, Ithaca, New York.
- OSHA 2018. Website: <https://www.osha.gov/SLTC/hydrogensulfide/standards.html>
- Pronto, J., C.A. Gooch, and S. Weeks. 2014. Biogas Clean-up and Utilization Systems. www.manuremanagement.cornell.edu
- Pronto, J., C.A. Gooch, S. Weeks, and N. Brown. 2014. Technician's Start-up and Operation Guide. www.manuremanagement.cornell.edu
- Pronto, J., Gooch, C.A., Wright, P.E. October 2017. *Meeting New York State's Energy, Environmental and Economic Goals While Strengthening Dairy Farms Through the Widespread Adoption of Manure-Based Anaerobic Digestion Technology*. Working Paper
- Schroeder, V., Schalau, B., Molnarne, M. 2014. "Explosion protection in biogas and hybrid power plants." *Procedia Engineering*, 84 (1) 259-272.
- Scott, N.R., I. Clark, C. Gooch, R. Peterson, W. Shayya, D. Goodale. 2007. "Review of Curriculum Content and Programs for Anaerobic Digestion Education and Training". NYSERDA Project No. 9446.
- Shelford, T.J. and C. Gooch. 2017. *Hydrogen Sulfide Removal from Biogas – Part 3A: Iron Sponge Basics*. Fact Sheet. Cornell PRO-Dairy Dairy Environmental Systems Program, Cornell University, Ithaca, New York.
- United States Department of Energy (DOE). 2013. *Fair Oaks Farms and AMP Americas Transform Waste into Fuel*. Article published: March 7, 2013. Website: <https://energy.gov/articles/fair-oaks-farms-and-amp-americas-transform-waste-fuel>

- United States Environmental Protection Agency. Technology Transfer, 1979. *Process design manual for sludge treatment and disposal*. US Environmental Protection Agency.
- van Lier, J.B., 1996. Limitations of thermophilic anaerobic wastewater treatment and the consequences for process design. *Antonie van Leeuwenhoek*, 69(1), pp.1-14.
- Wellinger A., and Lindberg A. 2000. "Biogas upgrading and utilization." *IEA Bioenergy*. Task 24.
- Wellinger, A., Murphy, J.D. and Baxter, D. eds., 2013. *The biogas handbook: science, production and applications*. Elsevier.
- Wiegant, W.M., 1986. "Thermophilic anaerobic digestion for waste and wastewater treatment" (Doctoral dissertation, Wiegant).
- Wright, P.E. 2001. "Overview of Anaerobic Digestion Systems for Dairy Farms." *Proceedings of Dairy Manure Systems, Equipment and Technology Conference*; Rochester, New York, March 20-22. NRAES-143. Natural Resource, Agriculture, and Engineering Service. Cornell University, Ithaca, New York.
- Wright, P.E. 2018. Agricultural Engineer for PRO-DAIRY, Cornell University Cooperative Extension, Ithaca NY. Personal Communication

Appendix A. Additional Resources

The Cornell PRO-DAIRY Dairy Environmental Systems Program website houses many resources that may be of assistance before using this guide, depending on the knowledge and previous experience of the reader. Each major theme includes several sub-categories to more easily find specific information.

Anaerobic Digestion

- Biogas
 - Production
 - Cleanup
 - Utilization
- Digester Synergies
- Co-digestion
- Economics/Policy
- Technical Papers
- Case Studies
- GHG
- Digester Simulation Module – Greenhouse Synergy
- Safety
- Nutrient Management

Manure Management

- Conveyance
- Treatment
 - Compost
 - Separation
- Storage
- Application
- Case Studies
- Nutrient Management
- Emissions/Odor
- GHG
- Safety

Environmental Considerations

- Climate Change
- Soil & Water Conservation
- AMR
- Odor/Emissions

- GHG
- Nutrient Management

Software/Calculators

- Digester Simulation Module – Greenhouse Synergy
- Manure Storage Cover Calculator
- Ventilation Calculator
- Construction Cost Estimator

Safety

- Manure
- Facilities
- OSHA/Labor