

Flight

About the 4-H Science Toolkit Series: Flight

In this series of activities, children build various vehicles for flight – from kites to boomerangs to flying saucers. Through their construction and flight experiments, they learn about the science behind flight and begin to understand terms like drag, lift and payload. They also explore how flight is affected by factors such as the shape of an object, how it is thrown or launched and environmental factors such as wind speed.

All of these adventures call on students to predict what will happen, test their theories and share their results.

The lessons in this unit were developed by and are connected to the Department of Fiber Science & Apparel Design at Cornell University.

To find out more about fiber science, visit the Department of Fiber Science & Apparel Design at <http://www.human.cornell.edu/fsad/> and to find numerous resources related to aerospace technology and rocketry, check out the National Directory of 4-H Materials at <http://www.4-hdirectory.org>.

Flight Table of Contents

- Spinning Saucers:** Discover what makes a round objects like a saucer fly best.
- Awesome Airfoils:** Discover why the shape of an airplane wing helps airplanes fly.
- Rockin' Rocket:** Understand how rockets are launched and how scientists determine how much weight a rocket can carry.
- Hanky Parachute:** Learn how parachutes work.
- Straw Kites:** Build kites to experiment with lift and drag.
- Boomin' Boomerangs:** Learn why a boomerang works and try different boomerang shapes.

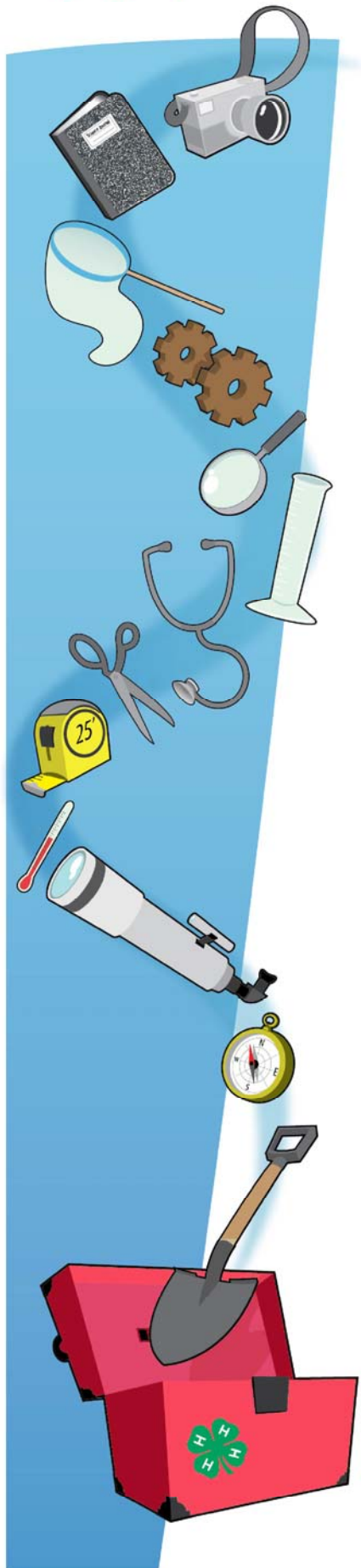

Flight: Spinning Saucers

Activity Series:
Flight
Grade: 1-5
Time: 45 min.

Main Idea

Round objects sail best with a circular rotation and balanced weight.

Motivator

University of Florida professor Subrata Roy made a 6-inch flying saucer and plans to create human-sized variations in the future. He prefers the description “wingless electromagnetic air vehicle.”

Pre-Activity Questions

Before you start the activity, ask the students:

- Have you seen or read stories about unidentified flying objects (UFOs)?
- What is the best shape for a flying saucer?

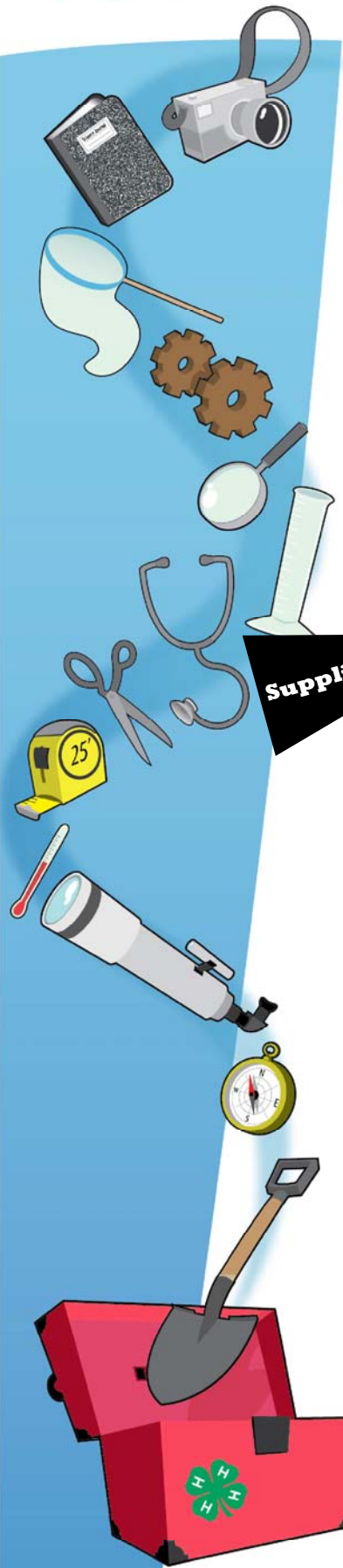

Supplies

Activity

- Paper plates
- Cellophane tape or stapler with staples
- Scissors
- Decorations (crayons, markers, stickers, glue, tissue paper, aluminum foil, glitter, tinsel, paper clips, ribbons, pipe cleaners, scraps of cloth or paper, etc.)

1. Staple or tape together two paper plates so that the inside (eating) surfaces face each other.
2. Decorate your flying saucer. You can draw/color designs or attach streamers, weights, pictures, ribbons, glitter, etc.
3. Sail your saucer outdoors or in a spacious room.

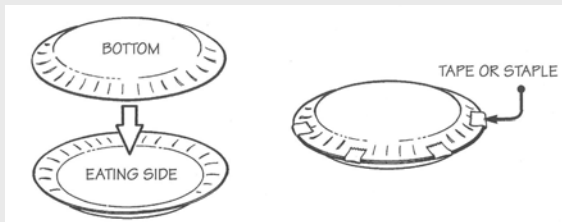

Science Checkup - Questions to ask to evaluate what was learned

- How many different saucers did you make?
- Which sailed the farthest and which sailed in the straightest line?

Objectives

- Observe the effects of added materials and throwing patterns on the flight of a saucer.

Learning Standards

(See Matrix)

Common SET Abilities 4-H projects address:

- Predict
- Hypothesize
- Evaluate
- State a Problem
- Research Problem
- Test
- Problem Solve
- Design Solutions
- Develop Solutions
- Measure
- Collect Data
- Draw/Design
- Build/Construct
- Use tools
- Observe
- Communicate
- Organize
- Infer
- Question
- Plan Investigation
- Summarize
- Invent
- Interpret
- Categorize
- Model/Graph
- Troubleshoot
- Redesign
- Optimize
- Collaborate
- Compare

Contributed By

Charlotte Coffman,
Department of
Fiber Science &
Apparel Design,
Cornell University

Flight: Spinning Saucers

- ❑ Describe the arm and wrist movements you used. Did you try spinning it like a Frisbee®? Or throwing it like a baseball? Or another method?
- ❑ Did you change the weight of the saucer with your decorations?
- ❑ Did the weight of the plate affect the way the saucer sailed? How?
- ❑ Was it important to place the weights evenly around the plate?
- ❑ Did streamers affect the speed or balance of your saucer? How?

Extensions

- Hold a distance competition, setting markers every 10 feet. Each player gets three throws. Average the distances and name a winner!
- Use reflective tape or glow-in-the-dark stickers and sail the saucers at night.
- Try to sail your saucer through suspended hoops of different sizes (hula, quilting and embroidery hoops).
- Make saucers using different sized plates. Measure the circumference and diameter of the plates and determine if the size of the plate affects flying distance.

Vocabulary

Circumference: The distance around a circle.

Diameter: The distance across a circle through the center.

Background Resources

- *Spinning Saucer* is adapted from the “*Disk 1: Flying Saucer*” activity in *The Fabric/Flight Connection*, Cornell Cooperative Extension, Cornell University.
- *Things That Fly*, Kate Little, Tulsa, Okla.: EDC, 1987.
- *Flight and Flying Machines*, Steve Parker, Rev. Ed. New York: Dorling Kindersley, 1993.
- The World’s first flying saucer, <http://www.scientificamerican.com/article.cfm?id=worlds-first-flying-saucer>

Flight: Awesome Airfoils

Activity Series:
Flight
Grade: 1-5
Time: 45 min.

Main Idea

The airfoil shape allows the air above the curved surface to move faster than the air below. Fast moving air has a lower air pressure than slow moving air. The higher air pressure below the airfoil creates lift that overcomes gravity and allows objects to fly.

Motivator

The first U.S. coast-to-coast airplane flight was in 1911; it took 49 days!

Pre-Activity Questions

Before you start the activity, ask the students:

- Describe the shape of an airplane wing.
- Can you think of other things with a similar shape? (Examples: propellers, sails)
- Have you wondered why people say that airplanes “lift off”? (See vocabulary: lift)



Supplies

Activity

- Piece of paper (8 1/2 in. square works well)
- Cellophane tape

1. Fold paper diagonally, leaving a 1 inch (2.5 cm) space along edges.
2. Fold bottom edge up about 1 inch (2.5 cm).
3. Bring outside points of base together, tucking one inside the other (bend, don't fold) and secure with tape.

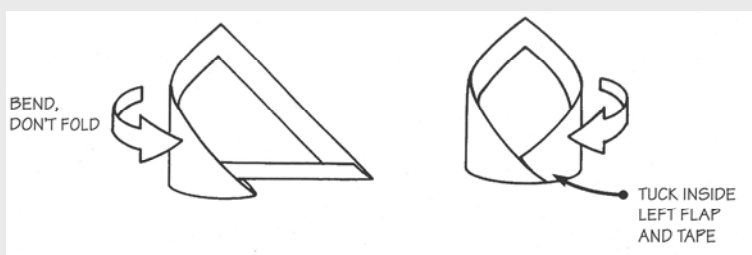
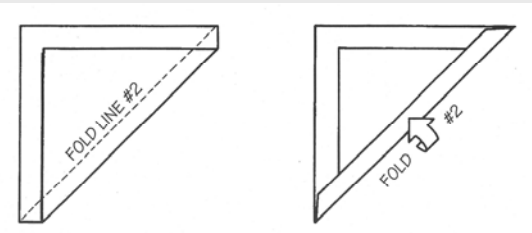
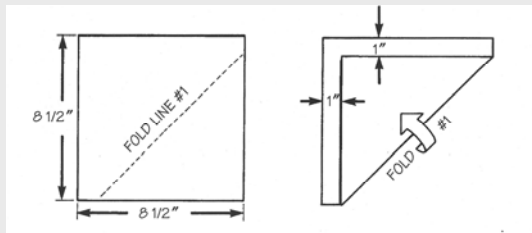

4. Grasp airfoil at the apex – the point farthest away from the folded base —and throw as if throwing a baseball, overhanded.

Objectives

- Understand why an airfoil shape facilitates flight.

Learning Standards

(See Matrix)

Common SET Abilities 4-H projects address:

- Predict
- Hypothesize
- Evaluate
- State a Problem
- Research Problem
- Test
- Problem Solve
- Design Solutions
- Develop Solutions
- Measure
- Collect Data
- Draw/Design
- Build/Construct
- Use tools
- Observe
- Communicate
- Organize
- Infer
- Question
- Plan Investigation
- Summarize
- Invent
- Interpret
- Categorize
- Model/Graph
- Troubleshoot
- Redesign
- Optimize
- Collaborate
- Compare

Contributed By
Charlotte Coffman,
Department of
Fiber Science &
Apparel Design,
Cornell University

Flight: Awesome Airfoils

Science Checkup — Questions to ask to evaluate what was learned

- ❑ Compare the shape of this airfoil to the shape of an airplane wing.
- ❑ Which side of the airfoil was in the downward position? (The airfoil side with the apex is heavier and is kept in the downward direction by gravity, which stabilizes its flight.)
- ❑ Can you imagine why this shape is important? (See vocabulary: airfoil.)

Extensions

- Try throwing the airfoil underhanded as in a softball pitch.
- Try larger pieces of paper.
- Draw an airplane that has its wings curved upward and joined together.

Vocabulary

Airfoil: Streamlined structure that is flat on the bottom and curved on the top. The leading edge is longer than the trailing edge.

Apex: The peak or point of the airfoil.

Lift: Upward force that overcomes the effect of gravity.

Background Resources

- Awesome Airfoil is adapted from the “Airplane 2: Airfoil” activity in *The Fabric/Flight Connection*, Cornell Cooperative Extension, Cornell University.
- *Gliders: How to Build and Fly Them*, Paul Garrison, New York: Drake, 1978.
- *Airborne: The Search for the Secret of Flight*, Richard Maurer, New York: Simon and Schuster for Young Readers, 1990.
- *The Best Paper Aircraft*, Campbell Morris, New York: Perigee, 1986.
- NASA SciFiles, http://scifiles.larc.nasa.gov/text/kids/Problem_Board/problems/flight/lift2.html
- More on Bernoulli’s Principle, http://www.sciencekidsathome.com/science_topics/flight.html#Trivia%20Answers
- Paper airplanes, <http://www.fatlion.com/science/paperairplanes.html>

Flight: Rockin' Rocket

Activity Series:
Flight
Grade: 1-5
Time: 30-60 min

Motivator

British rocket brigades bombarded Fort McHenry in Maryland during the War of 1812, and it was these "bombs bursting in air" that inspired the writing of our national anthem, "The Star-Spangled Banner."

Main Idea

Rockets are thrust into the air by a propellant. Rockets will travel different distances when moving horizontally, vertically, or at a 45-degree angle.

Pre-Activity Questions

Before you start the activity, ask the students:

- Can you name a NASA rocket?
(Possible answers: Minuteman, Saturn, Atlas, Titan, Ares, Gemini, Ariane, Soyuz, space shuttle)
- Did you know that the space shuttle is pushed into orbit by several rocket engines and rocket boosters?

Activity

- Scissors
- Monofilament fishing line
- Plastic drinking straws
- Balloons (long, sausage-shaped)
- Masking or freezer tape
- Measuring tape or yardstick
- Pen, pencil, chalk, or marker
- Paper or chalkboard to record results

1. Cut pieces of monofilament line (at least 10 feet long) so that you have one for each two participants.
2. Fasten one end of the lines to a stable object such as the ceiling, wall, door or chair.
3. Thread a plastic drinking straw onto each line. Fasten loose end of line to a stable object to achieve a horizontal position.
4. Assign one partner to prepare the balloon and one to record distance traveled.
5. Blow up a balloon, but don't tie the end. Tape the inflated balloon to the straw. Position balloon underneath straw with its "nose" pointed toward the length of line.
6. Release balloon and record the distance traveled.
7. Repeat the same exercise three times. Then average your results.
8. Move one end of string so that it creates a vertical track. Repeat three trials, record distances and average results.
9. Move string so that it creates a 45-degree angle. Repeat three trials, record distances and average results.
10. Make chart comparing average performance along horizontal, vertical and 45-degree-angle tracks.

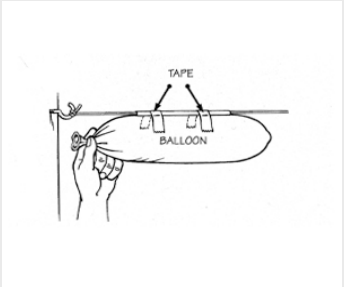

Objectives

- Make a rocket
- Record distance traveled at different angles
- Average and compare results

Learning Standards

(See Matrix)

Common SET Abilities 4-H projects address:

- Predict
- Hypothesize
- Evaluate
- State a Problem
- Research Problem
- Test
- Problem Solve
- Design Solutions
- Develop Solutions
- Measure
- Collect Data
- Draw/Design
- Build/Construct
- Use tools
- Observe
- Communicate
- Organize
- Infer
- Question
- Plan Investigation
- Summarize
- Invent
- Interpret
- Categorize
- Model/Graph
- Troubleshoot
- Redesign
- Optimize
- Collaborate
- Compare

Contributed By

Charlotte Coffman,
Department of
Fiber Science &
Apparel Design,
Cornell University

Flight: Rockin' Rocket

Vocabulary

Rocket: Vehicle propelled by ejection of gases.

Rocket engine: Part of rocket that carries the fuel and oxygen.

Science Checkup - Questions to ask to evaluate what was learned

- Did the distance the balloon traveled change with the angle of ascent? How?
- What is the fuel in this rocket? (air)
- Can you guess how this fuel differs from the fuel in real rockets? (Real rockets carry combustible propellants — fuel and oxidant. They combust to produce gas, which exerts pressure on the walls to push the rocket forward.)

Extensions

- Inflate some balloons halfway and compare their performance to balloons that are fully inflated.
- Inflate some balloons and release them into the air. How does the action of these balloons differ from the action of the rocket balloons?
- Try taping weights (pennies work well) onto your balloon. How many pennies can it carry?
- Position teams at each end of the string so they can exchange written messages via the balloon rocket.
- Compare performance of rockets made from a variety of balloon shapes and sizes.
- Modify the balloons with attached wings, pointed nose cones, streamers, or other features.

Background Resources

- *Rockin' Rocket* is adapted from the *Rocket 1: Rocket Blast Off* activity in *The Fabric/Flight Connection*, Cornell Cooperative Extension, Cornell University.
- *Aerospace Technology Education Series: Powered Flight*, Steve Bachmeyer, Pitsco, Pittsburg, KS. 1994.
- Rocket Science Projects Web site, www.ScienceBuddies.org
- Curious About Astronomy Web site: How do I build a model rocket?, curious.astro.cornell.edu/question.php?number=11

Flight: Hanky Parachute

Activity Series:
Flight
Grade: 1-5
Time: 30-60 min

Main Idea

Many factors determine how quickly a parachute will descend, including the weight of the payload, size of the parachute and air permeability of the parachute material.

Motivator

The first parachutist was a dog. His owner made the first successful human jump eight years later in 1793.

Pre-Activity Questions

Before you start the activity, ask the students:

- How are parachutes used? (Dropping people or supplies; skydiving; slowing the speed of race cars.)
- Should parachutes drop quickly or slowly? How do you think you could speed up or slow down a parachute?

Activity

- Handkerchief or other square of fabric
- Four strings at least 12 inches (30.5 cm) long
- Plastic container with snap-on lid (yogurt cup, film canister, etc.)
- Miscellaneous items to add weight by increments (e.g., popcorn, beans, pennies, washers)
- Stopwatch or watch with second hand (optional)

1. Gather corner of handkerchief or fabric. Wrap piece of string around point three times, and tie. Repeat for other corners.
2. Bring ends of strings together, trying to make them equal in length, and tie an overhand knot.
3. Place knotted string ends inside container and fasten lid.

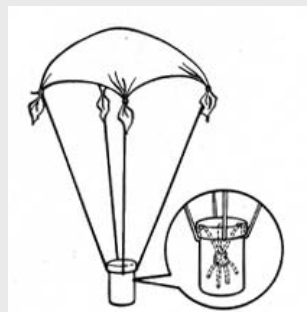
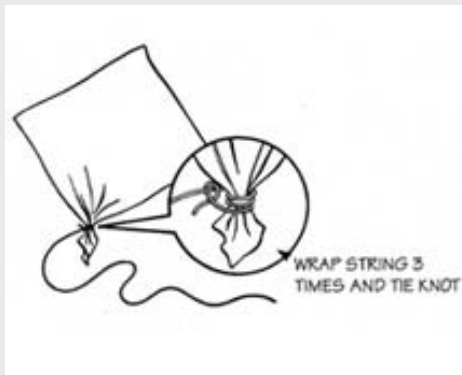

Supplies

Objectives

- To understand the various qualities of different parachutes

Learning Standards

(See Matrix)

Common SET Abilities 4-H projects address:

Predict
Hypothesize
Evaluate
State a Problem
Research Problem
Test
Problem Solve
Design Solutions
Develop Solutions
Measure
Collect Data
Draw/Design
Build/Construct
Use tools
Observe
Communicate
Organize
Infer
Question
Plan Investigation
Summarize
Invent
Interpret
Categorize
Model/Graph
Troubleshoot
Redesign
Optimize
Collaborate
Compare

Contributed By

Charlotte W. Coffman,
Department of Fiber Science & Apparel Design, Cornell University

Flight: Hanky Parachute

4. Wrap strings around parachute canopy and toss it in the air. Practice until canopy opens and canister floats to the ground.

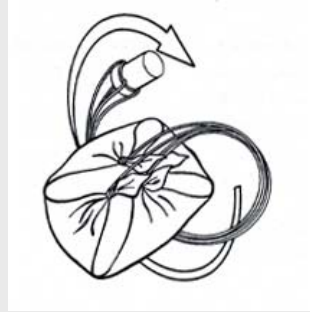

5. Repeat several times, loading more weight or payload into the container with each toss.
6. Rank speed of descent of each trial and compare. For example, first place (fastest) carried 25 beans; second place, 15 beans; third place (slowest), 5 beans. For more accurate times, use a stopwatch.

Science Checkup - Questions to ask to evaluate what was learned

- Did the parachutes open each time? If not, describe what happened.
- What happened if the parachute strings crossed?
- Did you toss the parachute to the same height every time?
- What worked best, a high toss or a low toss?
- What happened when you added weight to the container? Was it harder to toss? Did the parachute open better? Did it drop faster or slower?

Extensions

- Repeat drops, but add extra weight to the parachute instead of to the container. Add weight by applying metallic tape, cloth patches, painted designs, or glued objects.
- Try using different materials for the parachute, some heavier and some lighter than your original parachute. Do you think these materials allow air to pass through or do they capture air? How does the air permeability of the canopy affect the rate of descent?
- Try making larger and smaller parachutes. Can they carry more or less payload?

Vocabulary

Air permeability: How easily air passes through the material.

Parachute: An apparatus that traps and holds air.

Payload: Person or object carried by the parachute.

Canopy: The part of a parachute that opens up to catch the air.

Background Resources

- Hanky Parachute is adapted from the *Parachute 2: Bail Out* activity in *The Fabric/Flight Connection*, Cornell Cooperative Extension, Cornell University.
- *Aerospace Technology Education Series: On the Step & Go*, Steve Bachmeyer, Pitsco, Pittsburg, KS. 1991.
- *Parachutes: How They Work*, Eloise Katherine Engle, Putnam, NY, NY. 1972.
- Make a Parachute <www.seed.slb.com/en/scictr/lab/parachute/index.htm>
- Parachutes <www.nationalmuseum.af.mil/shared/media/document/AFD-060512-010.pdf>

Find this activity and more at: <http://nys4h.cce.cornell.edu>

Cornell Cooperative Extension is an equal opportunity, affirmative action educator and employer.

Flight: Straw Kites

Activity Series:

Flight

Grade: 3-6

Time: 30-60 min

Main Idea

Youth build kites to demonstrate lift (upward force to achieve and maintain flight) and drag (kite tails help steer and stabilize kites). They experiment with different kite materials.

Motivator

The first known kite was constructed by the Chinese more than 3000 years ago to frighten their enemies. Do you think kites are scary?

Pre-Activity Questions

Before you start the activity, ask the students:

- Do you own a kite? Describe the materials it is made of.
- Do all kites have tails? (No.)
- Do you know the purpose of a kite tail? (Help steer and stabilize.)

Activity

- Typing paper
- Tyvek (a Tyvek mailer yields two kites)
- Tissue paper
- Scissors
- Nine plastic straws
- Cellophane tape
- Elmer's white glue
- Hole punch
- Kite string, 12 inches (30.5 cm) for bridle; 60 yd. (55m) for the towline or flying line
- Waterproof paints or markers (optional)

1. Cut paper as follows:
 - Length = length of straw + 2 inches (5 cm)
 - Width = length of straw.
 - Draw colored design, if desired.

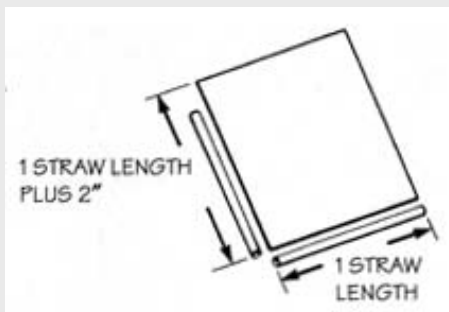

2. Place one straw lengthwise in center of paper and tape into place.

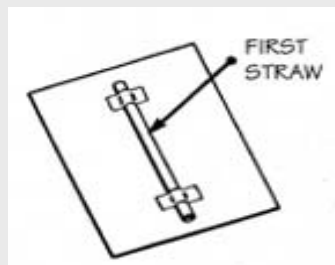

Objectives

- Make and fly a kite
- Experiment with various kite materials and observe their effects

Learning Standards

(See Matrix)

Common SET Abilities 4-H projects address:

Predict
Hypothesize
Evaluate
State a Problem
Research Problem
Test
Problem Solve
Design Solutions
Develop Solutions
Measure
Collect Data
Draw/Design
Build/Construct
Use tools
Observe
Communicate
Organize
Infer
Question
Plan Investigation
Summarize
Invent
Interpret
Categorize
Model/Graph
Troubleshoot
Redesign
Optimize
Collaborate
Compare

Contributed By

Charlotte Coffman,
Department of
Fiber Science &
Apparel Design,
Cornell University

Flight: Straw Kites

- Place second straw on top edge of paper. Glue straw to edge and roll it down paper until it meets center straw tip. Secure with glue.

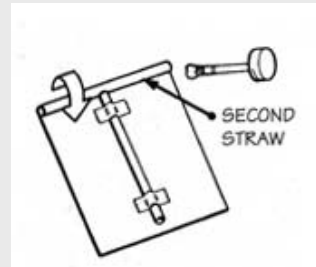

- Place third straw on bottom edge, glue, and roll it up until it meets bottom tip of center straw. Secure with glue.



- Make bridle by punching two holes on either side of center straw near top straw and two holes near bottom straw. Tie bridle string so it is about 4 to 6 in. (10 to 15 cm) from face of kite.

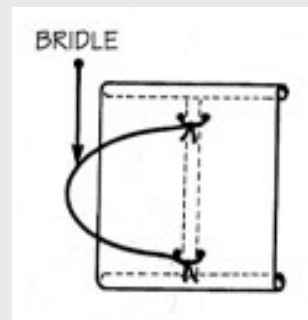

- Attach kite string to bridle with a slip knot as shown.

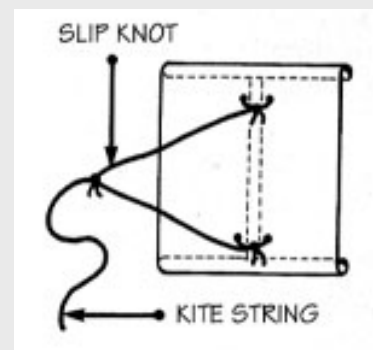

- For tails, cut strips of paper about 1 inch (2.5 cm) wide and glue to kite. In light breezes, use fewer tail sections. In stronger breezes, use more tail strips for added stability.

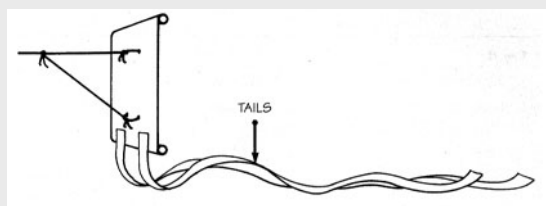

- Repeat steps 1-7 using Tyvek material.
- Fly your kites and compare how the different materials behave.

Flight: Straw Kites

Science Checkup - Questions to ask to evaluate what was learned

- What are the finished dimensions of your straw kite?
- How did kites made from different materials behave?
- What happened when the kite tails were shortened or lengthened?

Extensions

- For additional information on Tyvek, write to E.I. du Pont de Nemours & Co., Wilmington, DE 19898, or search the Internet.
- Shorten or lengthen kite tails and fly kites again, noticing the different flight behavior. Can you guess the purpose of the tail?

Vocabulary

Bridle: Strings that connects the kite to the towline; the bridle controls the angle of flight.

Drag: Air resistance to the movement of an object.

Kite: A light frame covered with thin material that is attached to a string and flown in the wind.

Lift: Upward force that overcomes gravity.

Tyvek: Registered trademark of DuPont for a spunbonded olefin fabric that is tear-resistant and inexpensive. It is used for mailers, protective coveralls, and kites.

Background Resources

- Straw Kites is adapted from the *Kite 2: Straw Kite activity* in *The Fabric/Flight Connection*, Cornell Cooperative Extension, Cornell University.
- *Aerospace Technology Education Series: Fly a Kite*, Steve Bachmeyer, Pitsco, Pittsburg, KS. 1991.
- *Kiteworks: Explorations in Kite Building and Flying*, Maxwell Eden, Sterling, NY. 1989.
- *Kites*, David Pelham, Overlook Press, Peter Mayer Publishers, Inc., Woodstock, NY. 1976, 2000.
- How to Make and fly Kites — A Complete Guide, www.howtomakeandflykites.com
- Making and Flying Kites, www.making-and-flying-kites.com/
- The Best of the Best Kite Making Plans, members.tripod.com/~TKOGunn1/kiteplans.htm

Flight: Boomin' Boomerangs

Activity Series:

Flight

Grade: 3-5

Time: 45 min.

Main Idea

Youth create a cardboard boomerang and learn how to throw it. Then they construct new boomerangs out of different materials and compare the flights.

Motivators

The oldest boomerang ever found is said to be about 30,000 years old. It was discovered in a cave in the Carpathian Mountains in Poland and was made of mammoth tusks!

Australian aborigines still sometimes use the returning boomerang as a hunting tool.

Pre-Activity Questions

Before you start the activity, ask the students:

- ❑ How are boomerangs used? (Examples: for hunting, percussion musical instruments, fire-starters, sporting competitions and toys)
- ❑ How far do you think a boomerang can fly? (World record is 780 feet or 238 meters!)

Activity

- ❑ Boomerang pattern (on page 3)
- ❑ Two pieces of cardboard at least 7 inches (18 cm) square (medium-sized cereal box panels work well)
- ❑ Pencil or pen
- ❑ Scissors
- ❑ Masking tape

1. Tape boomerang pattern to cardboard and cut out first boomerang.
2. Reshape boomerang pattern by cutting along dotted lines at blade tips.
3. Tape reshaped pattern to another piece of cardboard and cut out second boomerang.
4. Bend a smooth upward curve in the arm tips of both boomerangs.

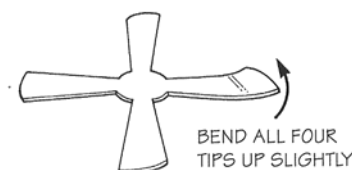
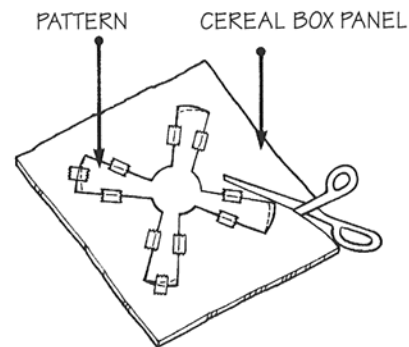

Objectives

- Make and throw a boomerang
- Compare the performance of different boomerang shapes

Learning Standards

(See Matrix)

Common SET Abilities 4-H projects address:

Predict
Hypothesize
Evaluate
State a Problem
Research Problem
Test
Problem Solve
Design Solutions
Develop Solutions
Measure
Collect Data
Draw/Design
Build/Construct
Use tools
Observe
Communicate
Organize
Infer
Question
Plan Investigation
Summarize
Invent
Interpret
Categorize
Model/Graph
Troubleshoot
Redesign
Optimize
Collaborate
Compare

Contributed By

Charlotte Coffman,
Department of
Fiber Science &
Apparel Design,
Cornell University

Flight: Boomin' Boomerangs

5. Fly and compare your two boomerangs. To fly your boomerangs, grasp one blade between your thumb, index finger and middle finger. Hold the boomerang straight up and down. Twist your wrist toward your body and throw it level and straight ahead, as you would a Frisbee®.
6. If the boomerang does not come back to you after a couple of throws, bend the three arms down slightly and try again. If it still doesn't work, try bending them up instead. Everyone throws a little differently, so what works for one person may not work for another.

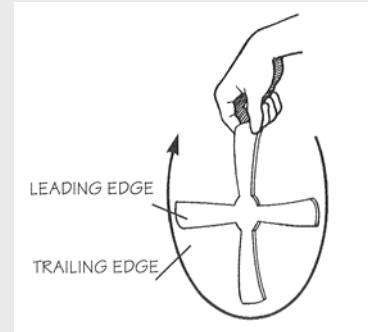

Science Checkup - Questions to ask to evaluate what was learned

- Describe the flight of the two boomerangs. What differences did you observe? (The boomerang with airfoils (leading edges are longer than trailing edges) should produce more lift and fly farther.)
- The curved-up tips help hold the boomerang upright. Did you try flying your boomerang with the tips curved downward? What did you observe?

Extensions

- How far can you throw each boomerang and still make it return?
- Try throwing the boomerangs at different angles. Which is the best for your boomerang?
- Make boomerangs from materials of different weights and thicknesses. Styrofoam meat trays are a good choice. Observe how differently they move.

Vocabulary

Leading Edge: Front edge of a flying object.

Trailing Edge: Back edge of a flying object.

Background Resources

- This activity is adapted from the "Boomerang 2: Cross-Stick Whirler" activity in *The Fabric/Flight Connection*, Cornell Cooperative Extension, Cornell University.
- *Fly It! Making and Flying Your Own Kites, Boomerangs, Helicopters, Hang Gliders, and Hand-Launched Gliders*, John Kaufmann, New York: Doubleday, 1980.
- How to Make a Boomerang with Kids, http://www.ehow.com/how_4853_394_boomerang-kids.html
- Boomerang Association of Australia, <http://www.boomerang.org.au>

Flight: Boomin' Boomerangs

Boomerang pattern

