

A COMPARATIVE LIFE CYCLE ASSESSMENT
OF A SOCIAL INTEREST HOUSING BUILDING:
BAMBOO VS. CONCRETE

A Thesis

Presented to the Faculty of the Graduate School
of Cornell University

In Partial Fulfillment of the Requirements for the Degree of
Master of Arts

by

Carolina Acevedo Pardo

August 2014

© 2014 Carolina Acevedo Pardo

ABSTRACT

In this study, the structural systems of two houses were compared for their environmental impacts: a real house made of Guadua Angustifolia Kunth, and a model house made of concrete. The goal of this research is to understand the difference in impacts caused by these two types of construction in Colombia, and the potential benefits of one type of construction over the other. The main hypothesis was proven correct, as the guadua structure contributes around 49% of the global warming potential (GWP) and 47% of the abiotic fossil fuel depletion of the concrete house. Although the results also indicate that the guadua structure contributes only around 36% of the ozone depletion potential (ODP) of the concrete structure, neither the concrete nor the guadua house contribute significantly to ODP within the scope of this study.

BIOGRAPHICAL SKETCH

Carolina Acevedo Pardo was born in Bogotá, Colombia in 1990 and has lived in North America since 1998. This thesis work comes after finishing a Bachelor of Science in Design and Environmental Analysis at Cornell in 2012, and working in sustainable building in Bogotá. She aspires to bring this experience, knowledge and training to the field, and hopes to work in Colombia in the future.

Para Beatriz Cárdenas

ACKNOWLEDGMENTS

Thank you to Jack Elliott, thesis chair and academic advisor during my studies, as well as Jonathan Ochshorn for your support and feedback during this process. Thank you to the Department of Design and Environmental Analysis for the generous grant which allowed me to get to Colombia, and to Juan Pardo and Cayetana García who brought me to the bamboo. Thanks to Ximena Londoño, Marcelo Villegas, Sebastián and Simón Velez, Carolina Salazar and Rodrigo Insignares for sharing with me your various enterprises centered around guadua and to Andrea Hernández Londoño for your willingness to help a fellow LCA researcher.

Finally, I'd like to thank my peers in DEA, all of the friends and family who offered advice and encouragement, and to Jun Ma and Laura Huacuja for your help in proofreading and editing this project.

TABLE OF CONTENTS

LIST OF FIGURES	vii
LIST OF TABLES	viii
LIST OF ABBREVIATIONS.....	ix
LIST OF SYMBOLS	xi
1. Introduction.....	1
2. Background.....	3
2.1 Colombian Context.....	3
2.1.1 Introduction to Guadua:.....	3
2.1.2 Construction with Guadua Bamboo:.....	3
2.1.3 Sustainability Initiatives in Colombia.....	4
2.1.4 VIS in Colombia.....	5
2.2 Why Build Sustainably?	9
Sustainable Building.....	9
2.3 Assessing Sustainability	12
2.4 Life Cycle Assessment.....	13
2.4.1 LCA History	14
2.4.2 LCA Methodology Overview.....	15
2.4.3 Life Cycle Thinking in the Construction Industry.....	21
2.4.4 Guadua and Concrete Construction in Colombia	28
3. Methods.....	35
3.1 Hypothesis.....	36
3.2 LCA Method	36
3.2.1 Goal and Scope:	36
3.2.2 Inventory Analysis.....	39
3.2.3 Impact Assessment Results.....	44
3.2.4 Interpretation.....	46
4. Conclusion and Implications.....	50
References.....	53

LIST OF FIGURES

Figure 1 : Diagram of LCA Stages	16
Figure 2: Cumulative Embodied and Operating Energy in Buildings	23
Figure 3 : Bahareque Construction Axon.....	28
Figure 4: Bamboo joinery Details.....	29
Figure 5 : Images of "Mampostería Confinada"	30
Figure 6 : Floor Plan of the Guadua Iteration of the House: Split Level.....	32
Figure 7: Floor Plan of the Concrete Iteration of the House	32
Figure 8: Structural System of the Guadua House.....	33
Figure 9: La Divina Providencia--Photograph of the Project.	34
Figure 10: Example of walls made of Guadua, Metallic mesh and Mortar.	34
Figure 11: Impact Assessment Results Concrete vs. Guadua : CML-IA v.3	45
Figure 12: Impact Assessment Results Concrete House Components: CML-IA V.3.....	45
Figure 13: Impact Assessment Results, Guadua House Components: CML-IA V.3.....	46

LIST OF TABLES

Table 1: Material Database Information.....	40
Table 2: Unit Conversion Assumptions	41
Table 3: Guadua House Total Quantities.....	41
Table 4: Concrete House Total Quantities	42
Table 5: Guadua Processing Data	43
Table 6: Impact Assessment Results.....	44
Table 7: Top 8 Contributors to Abiotic Depletion.....	48

LIST OF ABBREVIATIONS

AIA—American Institute of Architects

CAMACOL—Cámara Colombiana de la Construcción

CCCS—Consejo Colombiano de Construcción Sostenible (Colombian Green Building Council)

CELADE—Comisión Económica para América Latina y el Caribe (Economic Commission for Latin America and the Caribbean)

CML-IA v3-- Institute of Environmental Sciences—Impact Assessment

DANE – Departamento Administrativo Nacional de Estadística (Colombia)

GWP—Global Warming Potential

HVAC—Heating, Ventilation and Air Conditioning

ICONTEC—Instituto Colombiano de Normas Técnicas (Colombian Institute for Technical Norms)

iiSBE— International Initiative for a Sustainable Built Environment

IPCC—Intergovernmental Panel on Climate Change

ISO—International Organization for Standardization

LCA – Life Cycle Assessment

LCIA – Life Cycle Impact Assessment

MinVivienda – Ministerio de Vivienda (Housing Ministry)

ODP—Ozone Depletion Potential

REPA— Resource and Environmental Profile Analysis

UN—United Nations

USLCI—United States Life Cycle Inventory

VIS –Vivienda de Interés Social (Social Interest Housing)

SETAC—Society of Environmental Toxicology and Chemistry

TRACI 2.1—Tool for the Reduction and Assessment of Chemical and other environmental
Impacts

LIST OF SYMBOLS

CFC-11 eq— Trichlorofluoromethane equivalent

CH₄—methane

CO₂—Carbon Dioxide

CO₂ eq—Carbon Dioxide equivalent

MJ—Megajoules

1. Introduction

Guadua Angustifolia is a type of bamboo that is native to South America, with large areas of guadua existing in Colombia.¹ This rapid-growth building material has been used for centuries but since European settlement has come to be regarded as a building material associated with poverty because it is a cheap, accessible material commonly used for improvised housing.² However, recent uses of bamboo in high-end homes and high profile projects have brought attention to the beauty, strength and elegance of this humble building material. The most emblematic example is the Zeri pavilion made of guadua, designed by Colombian architect Simón Velez for the 2000 Hannover expo.³ The potential for bamboo reaches across to the reality of low-income housing; one in three households in Colombia is living in inadequate housing conditions. One third of these households do not even have housing. Response to this housing need is ongoing through the efforts of the Colombian Housing Ministry (Ministerio de Vivienda) and Ministry of the Environment and Sustainable Development (Ministerio de Ambiente y Desarrollo Sostenible) whose efforts include the health and wellbeing of citizens and occupants of housing projects and more recently the evolution towards more sustainable building practices. Current social interest housing is constructed with concrete and brick.⁴ Given the context, this study performs a life cycle assessment of a guadua-based building envelope for a low-income housing unit compared with a concrete-based envelope of the same unit in order to analyze, quantify and compare the environmental impacts of these two

¹ Ximena Londoño. El bambú en Colombia. *Biotecnología Vegetal* 11 no.3 (2011): 143-54. : Oscar Hidalgo Lopez. *Bamboo: The gift of the gods*. Bogota: The Author, 2003.

² Ibid; Marcelo Villegas. *New bamboo: Architecture and design*. Bogota: Villegas Editores, 2003.

³ Vegesack, Alexander von., Mateo Kries. *Grow your own house: Simon Velez and bamboo architecture*. (Weil am Rhein, Germany: Vitra Design Museum, 2000.)

⁴ Departamento administrativo nacional de estadística (DANE). *Metodología Déficit de Vivienda*, 2005.

building types. This study seeks to provide evidence that will foster the adoption of more sustainable building techniques for the low income housing sector in Colombia.

2. Background

2.1 Colombian Context

2.1.1 Introduction to Guadua:

Guadua angustifolia kunth has been rising in popularity from a scientific perspective and has been widely studied in Colombia. According to Ximena Londoño, an expert in bamboo, Colombia has 105 species of bamboo, of which 24 are endemic, 69 are woody species, and 36 are herbaceous. Of these, *Guadua angustifolia* kunth is the most important for its current use and potential future applications, and its scientific literature extends to the areas of taxonomy, molecular biology, biotechnology, ecology, biomass and ecosystem services, forestry inventories, propagation methods, preservation and drying, physical and mechanical properties, structural behavior, joints, and marketing studies.⁵ Londoño recognizes it is a material with a high potential for construction and building material applications that is not commercially exploited at this moment in Colombia.

This species of bamboo is a grass, which grows up to 20 cm in a day and reaches its full height in six months. The culm itself takes 4 to 5 years to mature into a structurally sound element. It can grow to a height of 30 meters, with a diameter up to 22 cm. Its compression strength fluctuates between 355 kg/cm² and 500 kg/cm².⁶

2.1.2 Construction with *Guadua* Bamboo:

Colombia is one of the regions of the world and the only country in Latin America to preserve most of its native bamboo species thanks to conservation efforts in the 1960s which

⁵ Ximena Londoño. *El bambú en Colombia*. (2011).

⁶ *Ibid.*

resulted in the regulation of National Parks in Colombia, as well as regulation of privately owned native flora and fauna. Because of this legislation, naturally existing guaduales or guadua forests are subject to strict conservation standards.⁷ Nevertheless, bamboo is still used for many applications in Colombia and neighboring countries. Colonial era construction in certain regions of Colombia was based on a guadua structure, and previous native cultures, among them the Quimbayas, used guadua for construction and for everyday artifacts and tools.⁸ Over the last fifty years however, guadua has come to be regarded as construction material for the poor; because of its low cost and ease of access it has been used in makeshift shelters by very poor populations. This image is slowly changing with high profile projects that not only showcase the beauty and strength of the building material, but also elevate its prestige. The Zeri pavilion built for the Expo 2000 World's Fair in Hannover Germany has become emblematic of bamboo building, which has led bamboo to be written into the German building codes.⁹ It has also been used increasingly in residential and commercial applications in Colombia.¹⁰ In 2010, guadua was included for the first time in the Colombian building codes, allowing for its use in residential one and two story buildings, an important step for increasing the credibility of guadua as a building material.¹¹

2.1.3 Sustainability Initiatives in Colombia

Sustainability Initiatives in Colombia: The Colombian government has recognized the importance of joining other world countries in implementing environmental legislation in an effort

⁷ Oscar Hidalgo Lopez. *Bamboo: The gift of the gods*, 2003, 36. : Decreto 2811 de Colombia, "Código Nacional e Recursos Renovables y de Protección al Medio Ambiente." 1974.

⁸ Salas Delgado, Eduardo. "Actualidad y futuro de la arquitectura de bambú en Colombia." (PhD diss., Universitat Politecnica de Catalunya, 2006), 89.

⁹ Alexander von.Vegesack, *Grow your own house*, 2000. : Villegas, *The New Bamboo*, 2003.

¹⁰ Villegas, *The New Bamboo*, 2003.

¹¹ Ximena Londoño. *El bambú en colombia*. (2011), 147.

to mitigate climate change impacts especially as it is one of the most bio-diverse countries in the world.¹² At the policy level Colombia has created a general framework for environmental protection, which has been modified throughout the years as global recognition of environmental degradation grows.¹³ In terms of private sector green building initiatives, the Colombian Green Building Council (or Consejo Colombiano de Construcción Sostenible, CCCS) was created in 2009, and although this entity does not serve the sole purpose of disseminating the LEED rating system, the progress of the CCCS and LEED in Colombia has been closely linked. In the same year, the first LEED project was registered in Colombia, and since then, 39 projects have been certified while more than 70 are in progress.¹⁴ These trends in the building sector provided the impetus for a Colombian initiative: the ICONTEC and Ministry for the Environment (Ministerio de Ambiente y Desarrollo Sostenible) developed the Colombian Environmental Seal (SAC – Sello Ambiental Colombiano). The SAC is a voluntary seal for green buildings or products based on premises similar to the LEED rating system, which seeks to transform building practice through market incentives, but the SAC aims to be more sensitive to the local context and industry.¹⁵

2.1.4 VIS in Colombia

¹² (Secretaría Distrital de Planeación (SNP). Documento tecnico soporte de la política de Construcción sostenible para bogotá D.C. Alcaldía de Bogotá, 2012;18.; Ximena Londoño. El bambú en colombia. (2011).

¹³ Unidad de Planeación Minero Energética (UPME). Normatividad ambiental Y sanitaria. in UPME. (Bogotá, 2014).http://www.upme.gov.co/guia_ambiental/carbon/gestion/politica/normativ/normativ.htm#NORMATIVIDAD_AMBIENTAL_Y_SANITARIA.

¹⁴ GBIG. “Colombia, overview.” in Green Building Information Gateway. Last modified 2014. <http://www.gbig.org/places/336>.

¹⁵ Min Ambiente. “Sea un consumidor responsable con el medio ambiente. in Ministerio de Ambiente y Desarrollo Sostenible.” Last updated 2014. Available from <http://www.minambiente.gov.co/contenido/contenido.aspx?catID=1277&conID=7745>.

Social Housing in Colombia—Vivienda de Interés Social: In the last seventy years, Colombia has gone from having a 58% rural population in 1954 to a 79% urban population in 2013.¹⁶ These changes have occurred due to the low productivity of the agricultural sector, the low availability of education and health services in rural areas, and the armed conflict that has displaced thousands of people. The resulting urban growth has been disorganized and unplanned, and the government has responded with a variety of housing policies. Since 1991, policy on Vivienda de Interés Social (VIS or Social Interest Housing) has been highly focused towards housing in areas that are considered marginal or subnormal. It is a policy that works on a large scale; between 1994 and 1997, 20,000 projects were undertaken: 6,500 of which were housing projects. Despite the need for improvement of existing housing units in marginalized neighborhoods, overwhelming attention and funds have gone towards the construction of new housing.¹⁷ In 2010 the government announced a new approach to low income housing, promising to build 100,000 free low-income housing units. In 2014, following the reelection of the same government, the Minister of Housing announced plans to build 300,000 units in the next few years. This 2014 effort is a continuation of the 2010 policy, which is seen as a motor of economic growth and comes in response to urbanization and population growth in Colombia.¹⁸

Although many housing projects in Colombia have historically been at a small scale and/or self-build projects, the 2010 housing policy was introduced to spur the use of ‘macro’ housing

¹⁶ Long Term Population Estimates and Projections 1950-2100.” *Indicators of population growth*. CELADE - Population Division of ECLAC. Revised 2013.

¹⁷ Cárdenas Tamayo, Raúl Ernesto. *Pobreza y vivienda de interés social en Colombia : Los programas de vivienda urbana de la red de solidaridad social*. (Bogotá: Universidad de los Andes, Centro Interdisciplinario de Estudios Regionales, 1999). ; SNP. Documento tecnico soporte de la política de Construcción sostenible para bogotá D.C. Alcaldía de Bogotá, 2012.

¹⁸ CAMACOL. *Informe económico*. Bogotá: Cámara Colombiana de la Construcción (2013), 23; MinVivienda. *En los próximos cuatro años se construirán 300 mil viviendas gratis más y otras 200 mil para ahorradores*. Last updated June 19 2014. <http://www.minvivienda.gov.co/sala-de-prensa/noticias/2014/junio/>.

projects, overwhelmingly built of reinforced concrete and concrete block. According to Beatriz Uribe, the Colombian Minister for the Environment, Housing and Territorial Development, if these macro projects are to be effective they must go beyond the scope of housing and provide urban services which can support education, health services, recreation, etc.¹⁹ Specifically, Uribe mentions Manizales, Pereira, and Medellin as three of the cities where these macro projects are under development and implementation. These cities are located in the central mountain range of the country, at altitudes propitious for the growth of guadua and where it is endemic. Utilizing this local resource within its recently code-compliant format in the construction of these housing projects is a sustainable alternative to current construction materials.²⁰

Even though environmental initiatives are already seeing their place in government publications related to VIS, they are not very effective. Sixty two percent of housing in Colombia is most often constructed by a system called “mampostería confinada,” or “confined masonry” which consists of a reinforced concrete structural system, filled in with masonry walls made of concrete block or brick. 15% is constructed by structural masonry walls (“mampostería estructural”) and 19%

¹⁹ For a more in-depth discussion of current topics in Colombian low-income housing policy, the 35th edition of the *Revista de Ingeniería* of the Universidad de los Andes in Bogotá contains the talks given at a conference focused around this topic at los Andes: Alan Gilbert, Clemencia Escallon, and Beatriz Uribe. Dossier: Housing in Latin America: Revised strategies. *Revista De Ingeniería*, 35, Universidad De Los Andes, 2011.

Some other issues that are involved with creating VIS include its institutional implementation, technical implementation, and financial viability. The technical implementation is not only about the materials selection and use, but also the housing quality of future and existing projects. In this issue of the Andes’ Engineering magazine, Clemencia Escallón argues that there should be more of an accompaniment alongside these projects to understand how they are working and if they are working within their complex social and economic realities.

²⁰ Reyes, C. A., and J. A. Ramirez, Ed. Ministerio de ambiente, Vivienda y desarrollo territorial (min vivienda). *Guías de asistencia técnica para vivienda de interés social no2: los materiales en la construcción de vivienda de interés social.* (Bogotá: Aincol, 2011).

by industrialized systems, which are made of concrete and steel which achieve higher quality ratings. Only 5% of housing is constructed with other materials such as guadua, wood, adobe, etc.²¹

In a 2011 publication containing sustainability guidelines for VIS construction, materials selection and lifecycle considerations are explained. Guadua and other traditional construction techniques are highlighted as being less environmentally impactful than highly processed building products.²² The level of detail provided serves as a general guideline for practitioners developing new buildings. However, there are no specific metrics assessing the level of impact generated by either conventional or traditional building practices. This study aims to begin to bridge this knowledge gap through a case study life cycle assessment.

²¹ UPME - Ecoingeniería. Estudio *Determinación de propiedades físicas y, estimación del consumo energético en la producción, de acero, concreto, vidrio, ladrillo y otros materiales, entre ellos los alternativos y otros de uso no tradicional, utilizados en la construcción de edificaciones colombianas*. (Cali, 2012).

²² Idib; Reyes, *Guías de asistencia técnica para vivienda de interés social no2*, 2011.

2.2 Why Build Sustainably?

In the context of a master's thesis, it is important to inquire into the assumptions that underpin the research agenda. This section provides a brief background into major moments of the rise of sustainable building which help to set the context of this study.

Sustainable Building

Although the emergence of ecological conscience and values predate and in some ways can be seen as a catalyst for sustainable building practices, there are several recognizable significant events that have marked the course of research and practice. Given that the examination of the ideological implications of these events is a topic for a thesis on its own, what follows is more of a contextual timeline that highlights some of the perspectives in the discourse on sustainability than an exhaustive analysis of the issue.

Environmental ideas, progress and buildings are all underpinned by what is valuable or valued within a given context. Even the term *sustainability* is ambiguous as to what it values since it can be applied to ecosystems and natural things as well as businesses and human activities. The 1987 UN World Commission on Environmental Development: *Our Common future (The Brundtland Report)* is often cited as the first comprehensive definition of sustainability. "1. Sustainable development is development that meets the needs of the present without compromising the ability of future generations to meet their own needs."²³ According to Williamson, Radford, and Bennets in *Understanding Sustainable Architecture*, the Brundtland report sees sustainable development as firmly situated within global economic, social and political frameworks, and its purpose is to improve

²³ United Nations. *Report of the World Commission on Environment and Development: Our Common Future*. World Commission on Environment and Development, 1987. Accessed July 7, 2014 <http://www.un-documents.net/our-common-future.pdf>: Chapter 2, Section 1.

human quality of life. Another UN conference, the Earth Summit of 1992 in Rio de Janeiro, set out *Agenda 21*, a proposal to stop environmental damage and promote sustainable development throughout the earth.²⁴ The International Union of Architects UIA 1993 World Congress of Architecture in Chicago was another important event dedicated to the emphasis of both environmental and social responsibilities in terms of sustainability.²⁵ William McDonough's *Hannover Principles* from the Expo 2000 World's fair builds upon the sustainable concept developed in the *Brundtland Report* to include not only humans but also different ecosystems. It also acknowledges limits to growth, and points toward life cycle thinking as a way to think sustainably.²⁶

These documents are signs of a change in what design practitioners and legislators value. As societies realize the damaging effects of human infrastructural development, normative documents like those mentioned above try to find a route towards mitigating these harmful effects. Some documents derive their motives from an anthropocentric perspective, that is, to conserve the environment for human prosperity, and others from an eco-centric or bio-centric perspective, which value natural ecosystems or living things for their own sakes.²⁷ All this is relevant to the investigation of environmental impacts of the built environment because these perspectives and values permeate the scientific methods used to evaluate and measure environmental impact. They also influence

²⁴ T.J. Williamson, Antony Radford and Helen Bennetts. *Understanding sustainable architecture*. (New York: Spon Press, 2003): 4.

²⁵ Allan Rodger. UIA sustainable futures: Responsible Architecture Project. *Architecture AU*. Last Updated January 24 2014.

²⁶ William Mc Donough. *The Hannover principles: Design for sustainability*. (William McDonough Architects, 1992).

²⁷ For a more detailed view of environmental ethics and views, Warwick Fox's essay "The New Ethics: Ethics in a Gaian Context", from Jules Pretty, ed., *Environment Vol. 1: Thinking and Knowing about the Environment and Nature*, London, Sage Press, 2006, 82-95. He outlines the trajectory of ethics in history and clearly defines the positions of Environmental Ethics, in addition to pointing out a possible new way of approaching ethics, even beyond the 'New' Environmental Ethics.

political decisions and construction regulations that set the stage for the building industry in its given context.

Sustainable building is a matter of responsibility; it is evident that business as usual is causing anthropogenic climate change (IPCC 2013) and that failing to modify our behaviors will likely continue to cause unforeseeable changes in our planet.²⁸ In the United States, the building sector consumes nearly half (47.6%) of all energy produced. In terms of electricity consumption, US buildings consume 74.9%.²⁹ Globally a similar trend is happening; the building sector accounts for 20-40% of the energy consumption of most developed countries and has overtaken the industrial and transportation sectors.³⁰ At the same time, the building industry is becoming the largest contributor to CO₂ emissions (44.6% of all US CO₂ emissions in 2012).³¹ Sustainable buildings need to be sourced, built and managed with an attention to detail so as to minimize CO₂ emissions and energy use. A sustainable approach to building is also one that is sensitive to the local place and its ecosystems, to human life and culture, and ultimately is more responsive and adaptive than a conventional western manner of building. The purpose of buildings is fundamentally to provide spaces where human needs and aspirations can be met; a sustainable approach to fulfilling this goal aims to be aware of environmental as well as social and economic realities.

²⁸ Lisa Alexander, Simon Allen, and Nathaniel Bindoff. *Working group I contribution to the IPCC fifth assessment report on climate change 2013: The physical science basis summary for policymakers*. Intergovernmental Panel on Climate Change, 5. 2013.

²⁹ *Buildings are the Problem*. Architecture 2030. http://architecture2030.org/the_problem/buildings_problem_why

³⁰ Luis Pérez-Lombard, José Ortiz, Christine Pout, A review on buildings energy consumption information. *Energy and Buildings*, V. 40, no.3, (2008): 394.

³¹ *Buildings are the Problem*. Architecture 2030. http://architecture2030.org/the_problem/buildings_problem_why

2.3 Assessing Sustainability

The last twenty to thirty years have seen the rise of many sustainable building initiatives and metrics; from voluntary rating systems to green building codes.³² Each code or rating system has different requirements, but they are all focused on reducing impacts—from land use change to energy consumption, and from water use to materials sourcing. The goal of these systems is to reduce the overall environmental impacts of the building industry (the energy consumption and emissions impacts mentioned above) by making incremental changes to building design, construction and operation.

Sustainable strategies for the building sector can be built in or adaptable, and each rating system used as a metric of environmental performance has its built in assumptions and biases. Some of the easiest loads to measure are energy and water consumption; efficient equipment and operational strategies can make a big difference in this kind of approach. Other strategies such as building orientation, material sourcing and site ecology (to name a few) are more difficult to quantify and ‘improve’ in architectural and facilities planning practice. The LEED (Leadership in Energy and Environmental Design) rating system, for example, is a point-based system with several chapters of sustainable strategies that are valued differently according to their assumed environmental impact. The Living Building Challenge by contrast is an imperative—a building must comply with all of its requirements in order to attain the certification. Another approach to assessing buildings that is gaining in both popularity and use is called Life Cycle Assessment (LCA). This last method is versatile in terms of the building system it can be applied to, and the stages of impact of the building. But what sets it apart from other metrics is the capacity to translate energy use and water savings into global environmental indicators like global warming, ozone depletion, and even land use

³² In the US the main voluntary green rating systems are: LEED (Leadership in Energy and Environmental Design), the Living Building Challenge, and Green Globes. There are also European and Chinese standards and building codes (IgCC) and in the US, California has been the pioneer state in terms of green building codes.

and human health effects. Moreover, LCA is finding its way into the building sector through different mechanisms. For instance, the latest version of the LEED rating system (4.0) has taken a departure from its previous incarnations in the Materials and Resources chapter for its application of life cycle assessment in practice. This chapter includes a credit that entails the completion of an LCA of the building being certified.³³ There are also architectural software tools that are incorporating LCA methods in order to provide environmental impact data during the design process.³⁴ The following section gives a background into the history and methodology of life cycle assessments, and life cycle thinking.

2.4 Life Cycle Assessment

The life cycle assessment (LCA) of a product refers to the quantification of impacts associated with that product from raw material extraction, transportation, through manufacturing and production, to use and maintenance, and at the end of the life cycle in its disposal or recycling. Each of these steps requires a flow of energy and materials that have impacts on the environment, biodiversity and human health.³⁵ Through a detailed analysis of each of these stages, an overall picture of environmental and human health impact begins to emerge. The history and methods of

³³ U.S. Green Building Council. 2013. *LEED reference guide for building design and construction*.

³⁴ The Athena Sustainable Materials Institute provides a free tool for simple building LCA calculations based on standard North American construction. The Revit software from Autodesk is also making available a new plug-in called Tally which will allow practitioners to conduct LCAs directly from the architectural model.

³⁵ iiSBE. 2004a. *Environmental framework: Annex 31 energy-related impact of buildings*. Canada Mortgage and Housing Corporation.

LCA have their beginnings in product manufacturing and packaging, and are now applied to many different kinds of systems, and most relevant to this study: buildings.

2.4.1 LCA History

LCA methodologies were begun around the late 1960s and early 70s, amid the energy crisis that pushed companies to examine material and energy flows in their production processes. Coca Cola is reported to have commissioned the first (unpublished) LCA study in which different beverage containers were analyzed.³⁶ In Europe, the first studies (at that time called ecobalance, or REPA—resource and environmental profile analysis) in Germany and Sweden were also carried out on beverage containers, and predate the energy crisis of 1973.³⁷ LCA research was undertaken in academic, public, and private sector studies in the 1970s and 1980s. One criticism that arose of life cycle claims was that manufacturers (in Europe) used this type of study to promote their products and as a result competing marketing claims became an issue. In the 1990s, academic societies began organizing conferences on LCA. The Society of Environmental Toxicology and Chemistry (SETAC), and the International Chamber of Commerce set up conferences and working groups to refine and standardize LCA methodology. Life cycle thinking was not a widespread concept outside of the packaging industry until the 1990s.³⁸ SETAC published the first LCA guidelines in the *Code of Practice* (SETAC 1993), a normative document that set out the requisite steps to carry out a life cycle

³⁶M. J. Gonzalez and N.J. Garcia. Assessment of the decrease of CO₂ emissions in the construction field through the selection of materials: Practical case study of three houses of low environmental impact. *Building and Environment*, 41, 7, (2006): 902-909.

³⁷Henrikke Baumann and Anne-Marie Tillman. The hitch hiker's guide to LCA : An orientation in life cycle assessment methodology and application. (Lund, Sweden: Studentlitteratur, 2004), 47.

38. Ibid, 82.

assessment, as opposed to an LCI- life cycle inventory.³⁹ The International Organization of Standardization has also published a series of methodology standards since 1997.⁴⁰ The use of LCA extended to other processes such as building materials, cars and chemicals in the 1990s.⁴¹

2.4.2 LCA Methodology Overview

The purpose of streamlining LCA methodology is to increase consistency in the studies undertaken, and to provide a framework for comparison and quality control. After the SETAC and ISO standardization efforts, LCA methodology consists of four parts: goal and scope, inventory analysis, impact assessment, and interpretation of the results.

Goal and Scope

The goal section defines the purpose of the study by identifying the reasons for carrying it out, potential applications, and the intended audience.⁴² The scope section defines the product or system to be studied in terms of its functional unit, system boundaries, allocation procedures, selected impact categories and methodology of impact assessment, data quality requirements, and type of critical review proposed.

³⁹ SETAC. *Guidelines for life-cycle assessment: A code of practice*. (Brussels: Society of Environmental Toxicology and Chemistry, 1993). An LCI or Life Cycle Inventory goes through the same steps as an LCA but only up to inventory analysis, not impact assessment. More detail on these stages of an LCA follows in the next section.

⁴⁰ Baumann, *The Hitchiker's guide to LCA*, 56.

41. Ibid, 60.

42. International Organization for Standardization. *Environmental Management : Life cycle assessment ; principles and framework*. Geneva, Switzerland: ISO, 2006: 11.

The functional unit is the system under study, and the system boundaries are the extent of the reference flows that will be taken into account in the study. In the case of building and construction LCAs, the functional unit can range from an entire building, to a square meter of that building. Other building-related LCAs deal with the life cycles of products and often look at the impact of an area (m²) of a given product over its life cycle. System boundaries for a building LCA might include the building process and building material impacts, but exclude transportation impacts of materials. Each study may include certain components and exclude others, and it is important that these system boundaries be clearly stated. The boundary of an LCA study is also set by the points within the life cycle which are to be studied. There are cradle to gate, cradle to cradle, and cradle to grave studies for instance, which each begin with the extraction of raw materials for production, but each end at a different point given the amount of data available or the purpose of the study as illustrated in Figure 1. The extent of the study is constrained by availability of data, time, and the goals of the study itself.

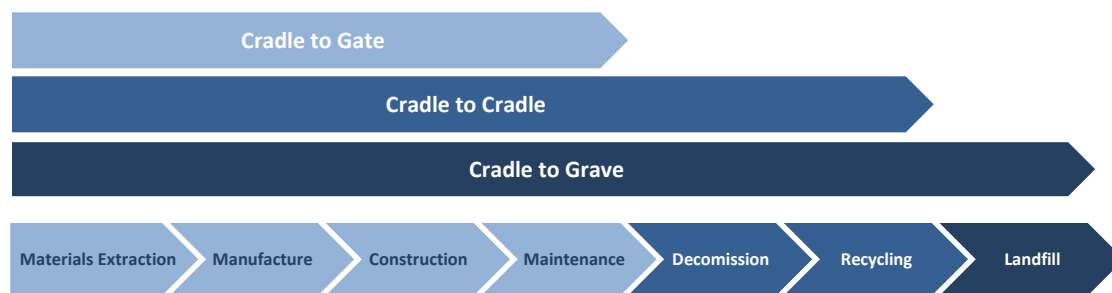

Figure 1 : Diagram of LCA Stages⁴³

More detail about allocation procedures, selected impact categories and impact assessment methodology will be given in the following sections.

⁴³ Although the most common used terminology in LCA practice is “cradle to grave” which delineates the return of material flows to the earth, “cradle to gate” and “cradle to cradle” are also useful terms which apply to products and building systems. In a building, there will be a combination of material flows that result in landfill disposal as well as in recycling (or even reuse). Note that transportation and energy use can also pertain to each of the stages outlined in this figure. Furthermore, cradle to cradle is not necessarily a benign outcome, as it could involve unsustainable energy inputs to accomplish the necessary recycling.

Inventory Analysis

This phase of the life cycle assessment consists of diagramming the flows of the system to be studied, collecting data for relevant activities, and calculating the environmental loads of the system. The flow chart for one study might change dramatically if the system boundaries change, making that an important step to detail at the outset of the study.

Data collection in LCA can be a complicated matter. Both quantitative and qualitative data are needed to describe a system, and the flowchart of a given process can grow as data is collected. Numerical data in terms of the inputs and outputs is needed, as well as qualitative data about the technologies used, emissions measurements, etc. Data validity is also an important aspect to consider when doing an LCA study as set out by ISO 14041 (1998), which requires thorough documentation.⁴⁴

The life cycle inventory is calculated by normalizing the data for one of the products in the flowchart. This step is important for industrial processes to ensure that the data refer to the same functional unit. The second step is to calculate the flows that link activities in the flowchart, then to calculate the flows that pass the system boundary, sum up the resource use and emissions and document the steps. In practice, LCA software packages can complete these calculation steps.

Allocation is a step that deals with materials or emissions flows that can be shared between processes or products. The ideal is to expand the system under study to account for all environmental loads. A much-debated example of allocation calculation is open loop recycling: which product lifecycle should take into account the extraction and waste handling impacts? Some methods allocate the extraction impacts to the first product used, and the waste disposal impacts to

⁴⁴Baumann, *The Hitchiker's guide to LCA*, 97-107.

the last product, while other methods tend to spread the resource extraction over the useful life of various products.⁴⁵

Impact Assessment

Once the life cycle inventory is done, the environmental impact assessment can begin. Impact categories describe the potential for environmental effects calculated as a worst-case scenario from known existing pollutant impact chains and resource use. The purpose of this step is to make impacts comparable and understandable. The general categories of impact include resource use, human health, and ecological consequences. These three are broken down into more specific impact categories, and different studies select different impact categories and methods to complete this assessment. Impact categories are also tricky in that they have implicit philosophical assumptions of value.⁴⁶ For instance, the global warming potential (GWP) and ozone depletion potential (ODP) indicators have been set by authoritative panels and are considered scientific and internationally recognized (even though they too make value choices and assumptions), while other indicators such as the “Disability Adjusted life Years” (DALYs)⁴⁷ which ranks different illnesses in order to quantify toxicity to humans, has not been regarded by the ISO as technical assumption in the same way that GWP and ODP are.⁴⁸

⁴⁵ Ibid., 114.

⁴⁶ Ibid., 129.

⁴⁷ GWP methodology has been developed and modified through the years by the Intergovernmental Panel on Climate Change (IPCC), and ODP methodology by the World Meteorological Organization (WMO). DALYs have been developed by the World Health Organization.

⁴⁸ Haes, Helias A. Udo ISO's Compromise on Comparative Assertions in Life Cycle Impact Assessment. *Journal of Industrial Ecology* v2 no.3 (1998). 4-7.

The steps of life cycle impact assessment (LCIA) are: impact category definition, classification, characterization, normalization, weighting, and data quality analysis.

- *Impact category definition* should be done so that chosen impact categories are relevant to the goal and scope definition.⁴⁹
- The *classification* step involves assigning LCI results to impact categories and requires knowledge of the impacts of specific pollutants.⁵⁰
- *Characterization* involves making all of the pollutants and or impacts of a certain category equivalent to each other in a given impact category. They are thus defined by a common impact and measured by this impact.⁵¹
- *Normalization* helps in understanding the magnitude of environmental impacts, for example the impacts at a country scale.
- In the *weighting* step the relative importance of an impact is weighted against others through various mechanisms such as monetarization (the price tag of environmental goods and services), authorized targets (the difference between the actual and ideal pollution scenarios), authoritative panels (experts set the recommended weight each impact and or set of impacts should have), proxies (one or a few parameters are representative of total environmental impact) and technology abatement (distance-to-technically feasible target-

⁴⁹ Baumann, *The Hitchiker's guide to LCA*, 133.

⁵⁰ Ibid., 139.

⁵¹ Ibid., 140-41.

thinking).⁵² “ISO does not allow weighting to be used in comparative assertions disclosed to the public.”⁵³

- *Data quality analysis* is used to analyze which parts of the life cycle are most important and or impactful. Data quality analysis can be done through dominance analysis, sensitivity analysis, and uncertainty analysis.

Characterization methods are of central importance to LCA since these methods imply value choices about which impacts to include and how to weight them. There are certain ‘ready made’ methods that come built in with certain software packages and are more user and novice friendly than a step-by-step impact assessment. In these methods, “the environmental information for various pollutants is aggregated into a characterization indicator or an index.”⁵⁴ Each method carries implicit value choices, mainly around the philosophical understandings of nature (fragile or resilient), humans (natural or cultural), and society (good or bad for the planet).⁵⁵

Besides these built-in value choices, certain processes are more difficult to link to specific impacts than others. For instance, emissions-related characterization methods are more developed than those concerning resource and land use: certain pollutants have known links to acidification, eutrophication, and global warming, whereas resources and land use are broader categories with differing definitions.

⁵² Ibid., 142-43.

⁵³ Mark Goedkoop, et al. *Introduction to LCA with sima pro*. Pré Consultants, 2013, 36.

⁵⁴ Ibid., 159.

⁵⁵ For more information on different environmental outlooks, please see section

Interpreting LCA Results

The final step of an LCA is the interpretation of results. This section of an LCA is about understanding the impacts and presenting them in an appropriate way to the intended audience. According to the ISO 2006 standards, reporting should include: “the relationship with the LCI results, a description of the data quality, the category endpoints to be protected, the selection of impact categories, the characterization models, the factors and environmental mechanisms, the indicator results profile.”⁵⁶

2.4.3 Life Cycle Thinking in the Construction Industry

As we have seen, life cycle assessment is an area that has been developed mostly with products and production processes. Its application to building life cycle is becoming increasingly relevant in the design phase of projects to help inform design decisions.⁵⁷ LCAs in the construction industry can give insight into the environmental impacts of the different life phases of a building, the energy use and carbon footprint, the materials implications and the costs or benefits of using any one particular process or material during the construction, operation, or disposal of the building. Since buildings are such complex systems, the studies conducted to date tend to focus on case studies of actual or simulated buildings, with a range of goals and parameters of systems under study.

⁵⁶ International Organization for Standardization. 14040 *Environmental Management : Life cycle assessment ; principles and framework*. Geneva, Switzerland: ISO, 2006: 16.

⁵⁷ Bayer, C., M. Gamble, R. Gentry, and J. Surabhi. *AIA guide to building life cycle assessment in practice*. American Institute of Publishers (2010). ; iiSBE 2004a. *Environmental framework: Annex 31 energy-related environmental impact of buildings*. Canada Mortgage and Housing Corporation.

However, the idea of a building life cycle and its related material and energy flows has been studied for at least 20 years, including studies that predate ISO standards as well as studies that follow them. The purposes of environmental impact studies for buildings have varied agendas: some studies explicitly try to set building and design recommendations that can apply to larger national or even global contexts, while others have a more narrow focus in order to try to understand the impacts of one particular building or a group of buildings.

Significant Findings

There have been significant findings with respect to materials use and energy flows for buildings in terms of their life cycle impacts. The following sections describe different approaches to LCAs of buildings, and the research that has been done on gradual in this area.

Embodied Energy and Operational Energy

Buildings are high consumers of energy: they represent around 40% of global embodied and operational energy.⁵⁸ There are two main ways energy is consumed by buildings: (1) the embodied energy used in the process of extraction and manufacture of building components, assembly, renovation and final disposal, and (2) the operational energy consumed in the functional use of the building in terms of its lighting load, HVAC, and operation of appliances.

Operational energy has been identified as the most significant factor of environmental impact during the life of a building.⁵⁹ Energy consumption in the use phase can account for a

⁵⁸ Dixit, et al. Identification of parameters for embodied energy measurement: A literature review, (2010): 1238-47.

⁵⁹ Blengini G.A. Life cycle of buildings, demolition and recycling potential: A case study in Turin, Italy. *Build. Environ. Building and Environment* 44 no. 2 (2009): 319-30. : Thormark, C. The effect of material choice on the total energy need and recycling potential of a building. *Building and Environment* 41 no. 8 (2006): 1019-26.

majority of the total energy footprint of a building. Adalberth et al. in their study of four houses in Sweden, found that the operational energy was a very significant factor—electricity mix had the most significant reduction potential for energy consumption.⁶⁰ Advances are being made in the potential to reduce operational energy as energy efficient appliances and fixtures, along with insulation and energy monitoring, become more common in practice, making embodied energy an ever more important factor.⁶¹ The setting of the current study, low income housing in Colombia, is quite different from this Swedish study; there the operational energy would weigh heavily for heating in the winter, while unconditioned housing in a year-round temperate climate would accrue a smaller operational energy bill in Colombia.

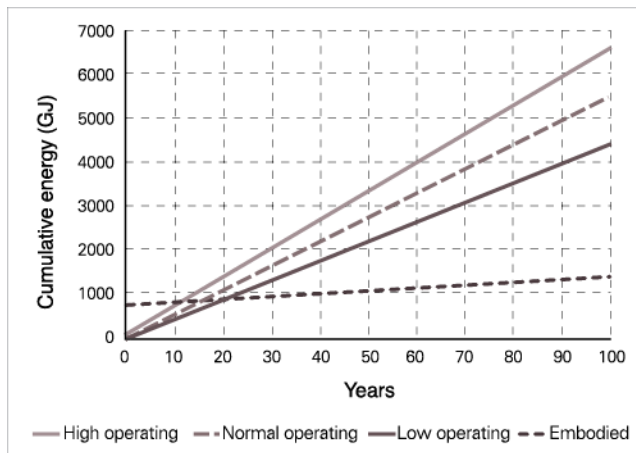

Figure 2: Cumulative Embodied and Operating Energy in Buildings⁶²

Embodied energy is also an important factor for building impact, but is more difficult to quantify. Certain authors count the upstream energy consuming processes of a given product or building, while others

consider the energy expended at every stage of the life cycle.⁶³ Despite these inconsistencies and lack of a framework to calculate embodied energy, Dixit concludes: “embodied energy accounts for a

⁶⁰ K. Adalberth, A. Almgren, and EH.Petersen. Life cycle assessment of four multi family buildings. *International Journal Low Energy Sustainable Building* 2 (2001).

⁶¹ Dixit, et al. Identification of parameters for embodied energy measurement: A literature review. *Energy and Buildings* 42 no.8 (2010): 1238-47.

⁶² Eric Adams, Jerome Connor, John Ochsendorf, and Rossella Nicolin, *1.964 Design for Sustainability, Fall 2006*. “Lecture 3 Current US Trends.” (Lecture Slides: MIT OpenCourseWare: Massachusetts Institute of Technology), <http://ocw.mit.edu/courses/civil-and-environmental-engineering/1-964-design-for-sustainability-fall-2006> (Accessed 11 Jul, 2014).

⁶³ Ibid., 1239.

significant proportion of life cycle energy.”⁶⁴ Numerically, two Australian studies have demonstrated that embodied energy costs could be equivalent to a range of 15 to 50 years of operational energy costs. [Figure 2](#) shows cumulative operational energy vs. embodied energy of buildings over a period of 100 years.⁶⁵

Carbon Emissions and Carbon Accounting

Energy and carbon are closely related issues; climate change is correlated with large-scale carbon emissions. Carbon emissions at this scale have not been seen since 55 million years ago during the Paleocene-Eocene Thermal Maximum that has been associated with huge environmental changes and mass extinction.⁶⁶ Carbon emissions from industrial processes through the burning of fossil fuels (coal, natural gas, and oil) have become a recognized indicator of environmental impact. Since the most significant changes in atmospheric carbon levels are due to the burning of fossil fuels for energy production, one way of accounting for carbon emissions is by using energy consumption data and calculating the resulting emissions from a given industrial process.

In addition to reducing carbon emissions, emphasis is placed on carbon capture in order to mitigate the surplus atmospheric carbon. Atmospheric carbon is captured in various ways, the most commonly cited being photosynthesis. Natural weathering of certain types of stones also serves to capture carbon by converting CO₂ into solid carbonate minerals. However these natural processes in existing forests, plantations and areas of exposed rocks are not capable of carbon capture at the rate that it is being produced.⁶⁷

⁶⁴ Ibid., 1240.

⁶⁵ Ibid., 1240.

⁶⁶ Stephenson, Michael H. *Returning carbon to nature*. (Waltham, Mass: Elsevier, 2013), 43.

⁶⁷ Ibid., 48.

Two of the major building materials that have been scrutinized and subject to many life cycle studies are concrete and wood. Trees capture CO₂ during their growth stages, and ‘store’ it in the form of wood products used for a variety of applications. At the end of their life cycle, wood products also have the potential to release their stored carbon back into the atmosphere as they are burned or they decompose in a landfill. However, the carbon accounting methodology used by the IPCC for global warming potential, measured in carbon dioxide equivalents (CO₂eq) excludes biogenic carbon CO₂ emissions from wood decomposing or being burned for fuel, allowing for a scenario of being “carbon positive.”⁶⁸ Concrete is composed of stone aggregates and cement. Cement production is carbon intensive because of its high heat (energy) requirements, as well as the process of calcination through which (at high temperatures) calcium carbonate (limestone) is decomposed into calcium oxide (lime) and CO₂. There are also carbon impacts associated with mining and transportation of aggregates. Concrete is estimated to be responsible for 7% of the world’s annual CO₂ production. Concrete also undergoes the reverse process during its lifecycle as it is ‘weathered.’ This reverse process is called carbonation and is associated with the breakdown of the material. However, it only involves the surface area of the exposed concrete; not the entire volume of concrete.⁶⁹

CO₂ Emissions and building Studies:

Comparative case studies of wood and concrete construction buildings have been done in various countries including Sweden, New Zealand, France, Japan, Britain—and they all point to concrete as a higher negative impact material.

⁶⁸ Emmanuel Gentil, Thomas H. Christensen, and Emmanuelle Aoustin Greenhouse gas accounting and waste management *Waste Manag Res* 27 (2009): 696-706, doi:10.1177/0734242X09346702 .<http://e3solutionsinc.com/home/index.php/top-resources/articles/171-biogenic-co2>

⁶⁹ Nick Winter. “Carbonation of cement.” <http://www.understanding-cement.com/carbonation.html>

Borjesson and Gustavsson conducted an analysis of the CO₂ and CH₄ flows in a building in Sweden. The case study is a wood-based multi-story building in southern Sweden, compared with the same building (theoretical) made of concrete. The conclusion is that the concrete building uses 68-80% more embodied energy than the wood building. They also took into consideration the carbonation of concrete at the end of the life cycle, and when they factored in this change, the energy difference was less dramatic.⁷⁰ Another study that takes a more nuanced view of the impacts of carbon is one done by Buchanan and Levine (1999). They argue that while wood is a material that sequesters carbon (CO₂), “the lower fossil fuel energy required for processing of wood compared with other materials is more important than the carbon stored in the wood.”⁷¹ They extrapolate their findings to a scenario of the New Zealand building industry and calculate a CO₂ emissions reduction of 20% if a greater percentage of national buildings were constructed with wood. They also point out the importance of sustainable forestry for this change of building materials to take place.

Bamboo and LCA studies

Bamboo is an obvious choice from the standpoint of sustainability and has received a lot of attention in the building industry with the advent of sustainable building initiatives and Colombian bamboo, *Guadua Angustifolia Kunth* has been studied from different perspectives. In terms of mechanical properties, Patricia Kaori Tekauchi and Juan Correal Daza have a growing body of research of both bamboo construction applications as well as entire pieces of bamboo culms.⁷²

⁷⁰ Pal Borjesson and Leif, Gustavsson. Greenhouse gas balances in building construction: Wood versus concrete from life-cycle and forest land-use perspectives. *Energy Policy* 28 no.9 (2000): 575-88.

⁷¹ Buchanan, A., Levine, B. (1999). Wood-based building Materials and atmospheric carbon emissions. *Environmental Science and Policy* 2. 428.

⁷²Both Takeuchi and Correal have a considerable body of work in this area, including the following: Camilo Flores Bastidas et al. Approach to the load resistance in two kinds of bamboo reinforced concrete slab. *AMR Advanced Materials Research* (2011): 459-63. : Juan Francisco Correal Daza and Juliana Arbelez C. Influence of age and

Guadua research has also been undertaken at the graduate level, such as an assessment of carbon capture for a given area of bamboo, and another study that analyzes the life cycle impacts of laminated bamboo boards manufactured in Colombia.⁷³ Van der Lugt, et al. did an LCA and LCC of construction of a bamboo bridge in Amsterdam to understand the implications of using bamboo in western countries and projects. Despite certain setbacks in terms of construction skillset required and difficulty in complying with building codes, bamboo was still deemed twenty times more favorable than other construction materials from a sustainability standpoint.⁷⁴ Another graduate thesis tackled the resource intensiveness of a bamboo building built for a low-income community in Manizales, Colombia in comparison with the same building made in concrete. Felipe Villegas Gonzales calculated the resource intensiveness in terms of the energy equivalence of building products and construction methods.⁷⁵ The present thesis seeks to build off of the existing research in this area, and in particular the “Guadua vs. Concrete” study done in 2005. Section 3.2 LCA Method” provides a more detailed account of the methodology that will be used.

height position on Colombian guadua angustifolia bamboo mechanical properties. *Maderas, Ciencia y Tecnología v12 n.2*, (2010): 105-113.

⁷³ The carbon sequestration thesis is the following: Ángela María Arango. “Posibilidades de la guadua para la mitigación del cambio climático. Caso: Eje Cafetero Colombiano.” (Undergraduate Thesis, Universidad Tecnológica de Pereira 2011.) ; The LCI of composite bamboo panels was done by Andrea Hernandez at the Universidad Tecnológica de Pereira towards her master’s thesis.

⁷⁴ P.van der Lugt, A.A.J.F. van den Dobbelsteen, J.J.A.Janssen. An environmental, economic and practical assessment of bamboo as a building material for supporting structures. *Construction and Building Materials* 20 no.9 (2006): 648-56.

⁷⁵ Felipe Villegas Gonzales. “Comparación consumos de recursos energéticos en la construcción de vivienda social: Guadua vs. concreto.” Masters’ Thesis, Universidad Nacional de Colombia Sede Manizales, 2005.

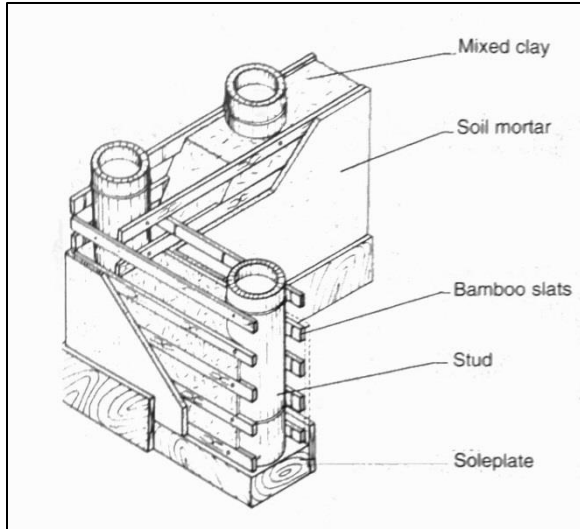

Figure 3 : Bahareque Construction Axon⁷⁶

2.4.4 Guadua and Concrete Construction in Colombia

Bamboo buildings in Colombia are usually made with treated culms, which come in six meter lengths. Preservation can be achieved by a variety of methods, including chemical preservatives, and

leaching, or leaving the bamboo culms in water for an extended period of time (4-6 weeks). A common practice is to leave the culms in a boric acid and borax solution for a period of four to six weeks, renewing the solution every week. Drying of bamboo culms is also done in different ways, the most common of which is air-drying in a covered enclosure.⁷⁷

Bamboo construction is also done in a variety of ways. One traditional method of using bamboo is called bahareque, in which bamboo is called bahareque, in which the structural bamboo culm is encased between two layers of flat bamboo sheets or slats, flat bamboo sheets or slats, and covered in plaster or mortar. These walls can be left hollow, or filled with clay or earth.

filled with clay or earth.

Figure 3 illustrates this construction. The joints are of particular importance in a bamboo structure, as the structural strength depends on the integrity of the member. Joints are made to fit

⁷⁶ Hidalgo-López, *Bamboo the gift of the gods*, 2003: 293.

⁷⁷ Stephane Schroder. "Chemical bamboo preservation" in *Guadua Bamboo*. Bogota: Colombia, 2012. <http://www.guadubamboo.com/blog/chemical-bamboo-preservation>.

around the round members, and are held together with wood or bamboo dowels, metal anchors, or in the most rudimentary scenarios, rope.⁷⁸ Some of these techniques are illustrated in Figure 4.

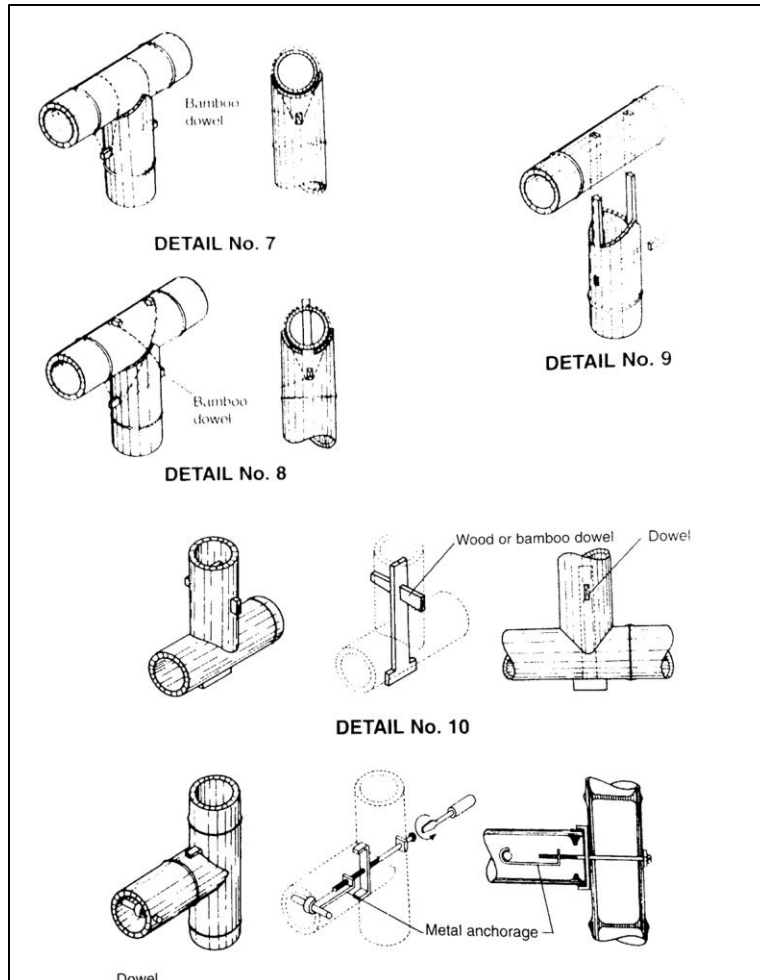

Figure 4: Bamboo joinery Details⁷⁹

⁷⁸ For a more complete description of bamboo construction methods, please see Hidalgo-López, *Bamboo the gift of the gods*, 2003.

⁷⁹ Hidalgo-López, *Bamboo the gift of the gods*, 2003: 228.

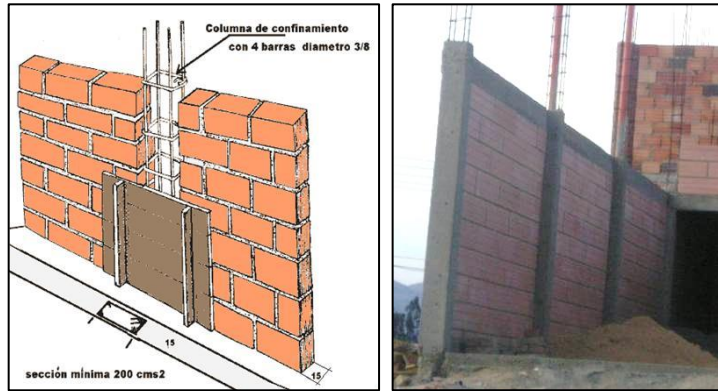

Figure 5 : Images of "Mampostería Confinada"⁸⁰

Concrete is the predominant construction material in Colombia. 62% of housing is constructed in a system called “mampostería confinada,” or “confined masonry” which consists of a reinforced concrete structural system filled in with masonry walls made of concrete block or brick, and divided by poured in place concrete slabs. This type of construction is illustrated in Figure 5. 15% is constructed by structural masonry walls (“mampostería estructural”) and 19% by industrialized systems, which are made of concrete and steel which achieve higher quality ratings.⁸¹

“Guadua vs. Concrete” (2005)

The 2005 study by Felipe Villegas Gonzales was based on a housing development in Manizales Colombia. The original guadua buildings were designed in 1991 as the culmination of an initiative by a religious community, the Sisters of the Presentation, with the help of Professor Gilberto Florez and students from the Universidad Nacional and the local low income housing authority. The structural system for these houses is a guadua system, resting on reinforced concrete

⁸⁰ “Lección 17: Mampostería Confinada.” In *Tecnología de la Construcción*. Universidad Nacional Abierta y a Distancia. Accessed July 8, 2014. http://datateca.unad.edu.co/contenidos/102803/MODULO_ACADEMICO/leccin__17_mamposteria_confinada.html

⁸¹ UPME - Ecoingeniería, 2012.

footings, and held in place with metal plates and concrete connections.⁸² Please see Figure 6 and Figure 8 for floor plans and drawings of the guadua structural system. The infill of the walls is achieved by stretching a metallic mesh from culm to culm and coating it with a cement and sand mortar: an example of this type of construction is shown in Figure 9 and Figure 10. Figure 9 shows the project: the houses on the right of the photograph are finished, and the ones on the left under construction. The concrete iteration of the house was designed by Villegas Gonzales, using a system called “mampostería confinada,” which consists of a reinforced concrete structural system, including poured in place concrete slabs, and the walls are filled in with concrete block. The floor plan of this house can be seen in Figure 7.

⁸² Villegas Gonzales. “Comparación consumos de recursos energéticos en la construcción de vivienda social: Guadua vs. Concreto,” 2005.

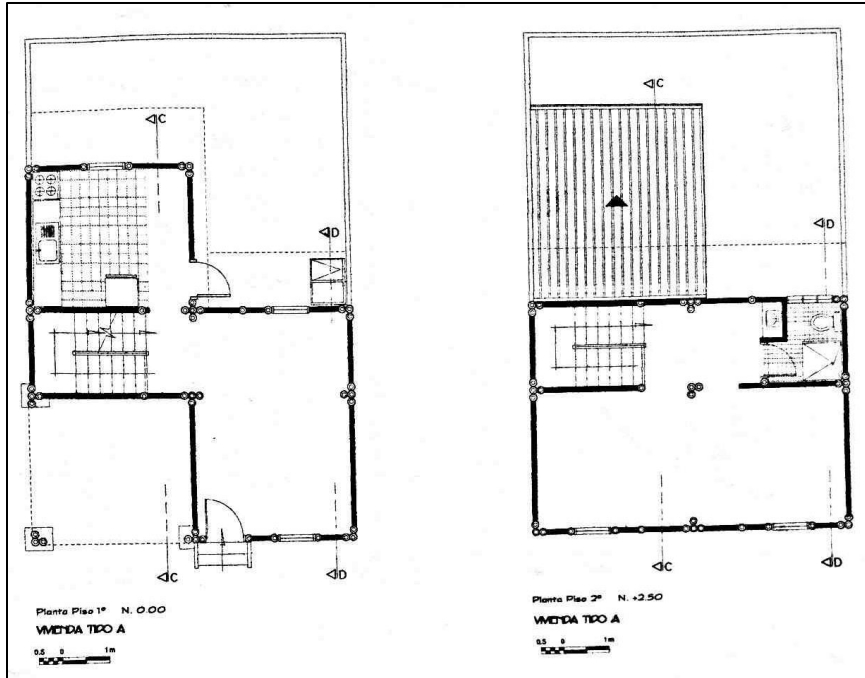

Figure 6 : Floor Plan of the Guadua Iteration of the House: Split Level⁸³

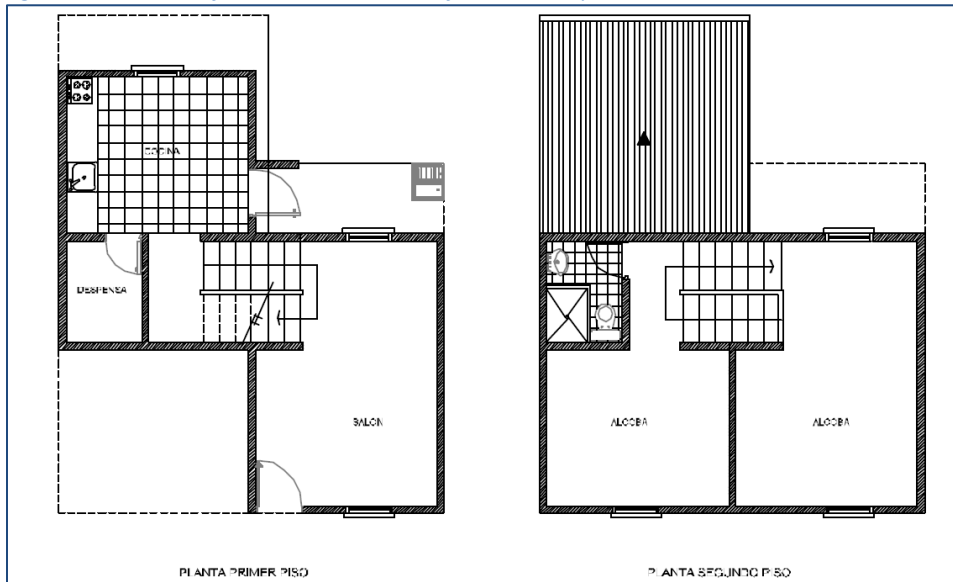

Figure 7: Floor Plan of the Concrete Iteration of the House⁸⁴

⁸³ Gilberto Florez. *Trabajo de Diseno, Construccion y Direccion "Urbanizacion la Divina Providencia."* (Universidad Nacional de Colombia: Manizales, 1996).

⁸⁴ Villegas Gonzales. "Comparación consumos de recursos energéticos en la construcción de vivienda social: Guadua vs. Concreto," 2005, 59.

El sistema constructivo
STRUCTURAL SYSTEM

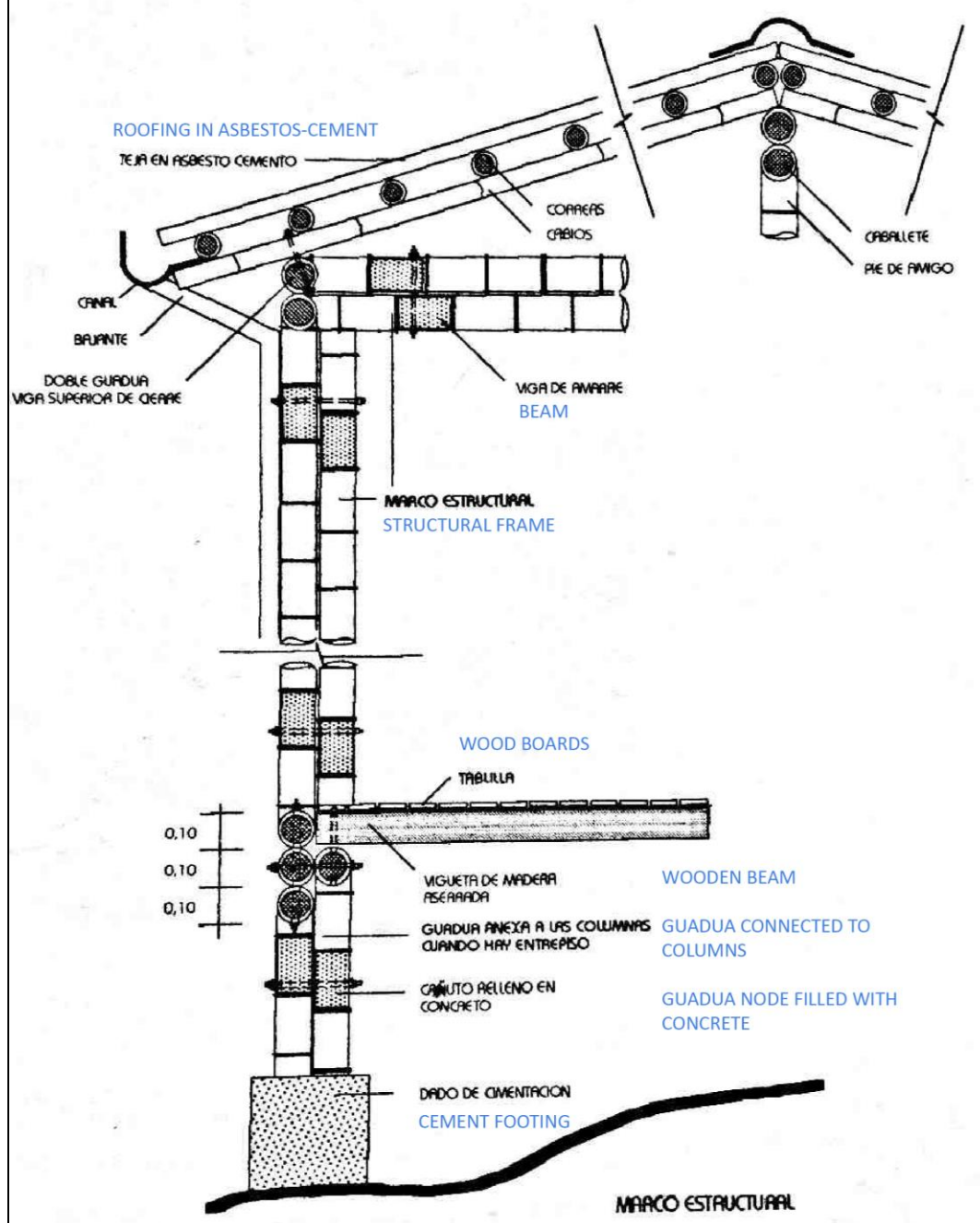

Figure 8: Structural System of the Guadua House



Figure 9: La Divina Providencia--Photograph of the Project.



Figure 10: Example of walls made of Guadua, Metallic mesh and Mortar⁸⁵.

⁸⁵ Photograph taken by the author.

3. Methods

Approach: Comparative LCA of Building Structural system

This study seeks to build off an existing study that compared a bamboo house to a concrete house. The bamboo house material quantities were taken from an existing building constructed in Manizales as part of a low-income housing project called La Divina Providencia developed by the local planning board and the Universidad Nacional de Colombia. The concrete house was modeled after the bamboo house in order to obtain representative material quantities in concrete. The hypothesis of Villegas Gonzalez (2005) was that bamboo construction was less resource intensive, and he found that the house made out of bamboo consumed 46,482 *fewer* mega joules of energy than the same house made of reinforced concrete. The study quantified the hours of operation of a concrete mixer, riverbed extraction of aggregates used for concrete, roofing material, guadua, electric fittings, wood, cement, km of transportation to the construction site, fuel and paint, and fixtures and finishes. The next step was to convert all of these material quantities into units of energy consumed, and thus come to the aforementioned differential in energy consumption for each type of construction.⁸⁶

The present study will limit the scope of comparison to the structural systems and walls of the buildings, since the goal is a comparison of environmental impacts and not a sum total. Since the interior finishes and fixtures, roofing material, and doors would be the same for both cases, they are excluded. This study seeks to quantify environmental impacts other than operational energy use in an effort to expand upon and quantify the other potential benefits of bamboo construction.

⁸⁶ Ibid.

Finally, the tools used for this project are the SimaPro 8 LCA software made by Pré, and the databases for life cycle impact information are: ecoinvent 3 for most production and transportation processes, and USLCI for one of the operations for harvesting the guadua.

3.1 Hypothesis

Given the context of the Colombian building industry and low-income housing practice, guadua is a building material with a lower impact than conventional concrete construction across several environmental indicators including GWP (measured in kg of CO₂ eq), ODP (measured in kg of CFC-11 eq), and abiotic depletion of fossil fuels (measured in MJ).

3.2 LCA Method

Approach: Comparative Case Study LCA of the Building Envelope

Following LCA methodology outlines, the following four sections will be addressed: (1) Goal and Scope, (2) Inventory Analysis, (3) Impact Assessment and (4) Interpreting LCA Results.

3.2.1 Goal and Scope:

- The **goal** of this study is to conduct a ‘cradle to gate’ life cycle assessment of the structural system of a low income house made of bamboo and the same house made of concrete.
- The intended audiences of this study are those academics interested in sustainable building, as well as current policy and construction decision makers regarding sustainable

options for low-income housing in Colombia. Results will be disseminated by way of Cornell's thesis registry and through publishing in relevant journals, as well as making it available to the scientific community and professional organizations in Colombia such as the Colombian Academy of Architects, as well as the Ministry of Housing.

- The **scope** of the present LCA consists of the functional unit, system boundary, impact categories, and method of impact assessment:⁸⁷
- The *functional unit* of this project is the structural system of the building including the foundations, walls and ceiling support structures in the case of this building in both its bamboo and concrete iterations.
- Since this will be a cradle-to-gate assessment, the *system boundary* for this project goes from the materials extraction and transportation to its construction.
- Impact categories and method of impact assessment: the impact categories chosen for this LCA are Global Warming Potential (kg CO₂ eq), Ozone Depletion Potential (CFC-11 eq), abiotic depletion of fossil fuels (MJ). Additionally, abiotic resource depletion is included (kg Sb eq) in order to understand the impact on non-fossil fuel mineral resource depletion. The method of impact assessment selected for this study is CML-IA v3. This internationally recognized impact assessment method quantifies the impacts of interest for this study, and is ensured to work with the database (ecoinvent) used since they are both European tools. Moreover, CML-IA characterizes impacts at the midpoint level, a practice with more scientific credibility than at an endpoint level.⁸⁸

⁸⁷ Please see section

2.4.2 *LCA Methodology Overview* for a more detailed explanation of the methodology.

⁸⁸ Midpoints and endpoints are two ways that impacts can be characterized. A midpoint methodology only goes so far as to characterize known impacts or equivalents, while an endpoint characterization goes beyond known impacts

Additional assumptions within the scope of the project:

The material quantities for both cases in this study are taken from those reported in Villegas Gonzales 2005. The materials and processes used for the present study are: the operation of a concrete mixer, aggregates used for concrete, cement, steel, guadua, wood, and transportation to the construction site. Although Villegas Gonzales' data do not account for extraction of raw materials, the ecoinvent v.3 database was used to select materials and processes that correspond to those used in Villegas' study. Within this database there is an option to include capital goods within the systems and processes. This means that the materials and processes needed to create the material or process in question are included within the system boundary, i.e. the mining operations are included within the dataset of a given aggregate building product such as sand.⁸⁹ Since the goal of this study is to compare two different building systems with the same functional unit, attributional modeling will be used. In this way, the capital goods (such as cement, sand, and gravel used for concrete) will contain an allocated share of energy and resource use of the processes that are required to produce or extract them.⁹⁰

Post-construction life cycle activities such as energy or water use, emissions from building materials, and final demolition of the building have been excluded from consideration because of the

to areas of environmental or health concerns and draws a link between these. For further information, please see: Bare, Jane C. *Developing a consistent decision-making framework by using the U.S. EPA's TRACI. in US EPA*. Last updated 2012. <http://www.epa.gov/nrmrl/std/traci/aiche2002paper.pdf>. ; Bare, J. C., Hofstetter, P., Pennington, D., & de Haes, H. Midpoints versus endpoints: The sacrifices and benefits. *The International Journal of Life Cycle Assessment*, 5(6) (2000); 319-326.

⁸⁹ Goedkoop. *Introduction to LCA with sima pro*, 2013, 10-11.

⁹⁰ Ibid., 12-14. There are two ways of dealing with upstream and downstream impacts of materials and processes in LCA methodology: system expansion, and allocation. System expansion means broadening the scope of the study to include all systems involved, while allocation assigns a certain amount of environmental, social or economic burden on the specific manufacturing, recycling, or other process by means of an allocation procedure. In ecoinvent v3, each material or process can be selected for consequential modeling (through system expansion) or attributional modeling (through allocation).

lack of available data for this project. Also excluded from the analysis is the manual labor of the workers, which although it is quantified in Villegas Gonzales' study, does not have an accessible equivalent in accepted databases. The last element that has been excluded from this study is the concrete formwork used in the construction phase. Since it is a material that is often reused in construction practice, it was not included.

3.2.2 Inventory Analysis

Inventory Analysis consists of data collection and analysis of the components of the functional unit.

Data collection: Material quantities for both bamboo and concrete versions of the building were taken from the previously described study by Villegas Gonzales (2005). Most of the life cycle inventory data was drawn from the ecoinvent database v3, and the data were modeled under allocation scenario by unit process.⁹¹ However, data for bamboo (*guadua angustifolia*) is not readily available in ecoinvent or other libraries, and so these data came from the masters' thesis of Andréa Hernandez Londoño, which investigated an LCA of a guadua three-ply building product produced in Chinchiná, Colombia. The pertinent energy and material flows consist in the felling of the bamboo culm, processing it onsite, and transporting it to the construction site. Table 1 shows the data sources for this part of the project.

Data Assumptions: Ecoinvent 3 includes data entries that correspond to global scenarios, not only European and American processes. As documented in Table 1, these entries are labeled either as global (GLO), or "rest of the world" (RoW). The only entry that is country-specific is the

⁹¹ Ibid, 20. In addition to consequential or attributional modeling, each entry in the ecoinvent 3 database can be modeled through a unit or a system process. The unit process was chosen for its greater transparency.

Brazilian electricity mix. Rather than include a global average, the Brazilian electricity mix was chosen for its similarity to the Colombian electricity mix.⁹² Another assumption included in this study is the quantity of water required for the concrete mix. Villegas Gonzalez (2005) did not include water in his study; here a 0.4 water to 1.0 cement ratio was estimated as is common practice.

MATERIAL INFORMATION					
Material - Permanent	Villegas, 2005 Unit	Alt. unit	Source	Database Entry: Category	Database Entry: Name
Cement	kg		Ecoinvent 3	Materials\ Construction \ Binders \ Market For	Cement, Portland {RoW}, Market For. Alloc, Def, U
Sand	m ³	kg	Ecoinvent 3	Materials\ Minerals\ Market For	Sand {GLO}, Market For. Alloc, Def, U
Gravel	m ³	kg	Ecoinvent 3	Materials \ Minerals\ Market For	Gravel, crushed {GLO} Market for, Alloc Def, U
Guadua	linear meters	kg	Hernandez Londoño		
Steel	kg		Ecoinvent 3	Material\Metals\ Ferro \ Market	Reinforcing Steel {GLO}, market for, alloc def. U
Wire	kg		Ecoinvent 3	Material\Metals\Ferro \Market	Steel, unalloyed {GLO}, market for, alloc def. U
Metal Fittings	kg		Ecoinvent 3	Material\Metals\Ferro \Market	Steel, unalloyed {GLO}, market for, alloc def. U
wooden floor	pulg ²	m ³	Ecoinvent 3	Wood\Products\Mark et	Sawn wood, softwood, raw, air dried {RoW} market for Alloc Def, U
Stone	m ³	kg	Ecoinvent 3	Materials\ Minerals\Market For	Gravel, round {GLO}, market for, Alloc Def, U
Water	-	kg	Ecoinvent 3	Materials\ Water\ Drinking Water\ Market	Tap Water at User {RoW}, market for, Alloc Def, U
Construction - Process			Source	Database Entry: Category	Database Entry: Name
5 hp Concrete mixer	kWh		Ecoinvent 3	Electricity country mix\Low Voltage\Market	Electricity, low voltage {BR} market for Alloc Def, U
Transportation			Source	Database Entry: Category	Database Entry: Name
Transportation	tkm		Ecoinvent 3	Processes\Transport	Transport, freight, light commercial vehicle {GLO} market for Alloc Def, U

Table 1: Material Database Information

Unit Conversions: Unit conversions from the data presented in Villegas Gonzales' (2005) study were required in order to fit with the corresponding materials from the ecoinvent database.

⁹² Energy Information Administration, *International Energy Statistics*. 2014. <http://www.eia.gov>

The unit conversion assumptions come directly from the Villegas Gonzalez study itself. The pulg² unit corresponds to square inches (pulgadas cuadradas) which are a common unit of measure for wood in this region of Colombia. The unit conversion factors are documented in Table 2.

Unit Conversion Assumptions	
Wood	0.00194 m ³ / pulg ²
Sand	1800 kg/ m ³
Gravel	1800 kg/ m ³
5 hp Concrete mixer/ hour	373 kWh
Stone	1600 kg/m ³

Table 2: Unit Conversion Assumptions

Transportation is measured in tonnes-kilometer (tkm) which is calculated by multiplying the distance that each material travels from the supplier to the building site by the number of trips required, and finally by the mass of the material in metric tonnes. These data can be found in Table 3 and Table 4 for each of the structures. Additionally, these tables show the total material quantities used in this study.

GUADUA HOUSE					
Material - Total	Qty	Unit		Component	Tkm
Cement	3424.00	kg			
Potable Water	1369.60	kg	}	Concrete	1909.500
Sand	48578.40	kg			
Gravel	7257.60	kg			
Guadua	1729.19	kg		Guadua	51.876
Steel			}	Steel	50.400
Wire	201.60	kg			
Metal Fittings					
Wooden Floor	0.90	m ³		Wooden floor	338.520
Construction - Process					
5 hp Concrete mixer	3580.80	kWh			

Table 3: Guadua House Total Quantities

CONCRETE HOUSE				
Material - Total	Qty	Unit	Component	Tkm
Cement	17033.30	kg	}	Concrete
Potable Water	6813.32	kg		
Sand	60561.36	kg		
Gravel	20669.04	kg		
Stone	4659.20	kg		
Steel	1135.20	kg	}	Steel
Wire				
Construction - Process				
5 hp Concrete mixer	10159.03	kWh		

Table 4: Concrete House Total Quantities

Guadua Data: Andrea Hernandez Londoño (2014) performed an LCA of a three-ply guadua board, whose functional unit was one finished three-ply board which used 12 three-meter pieces of guadua from the outset. Since the mass of bamboo changes depending on its humidity content, it is usually measured in linear meters (and this was the original unit used in Villegas Gonzalez, 2005). Hernandez Londoño's data was normalized for the production of six linear meters of guadua, which is the usable material extracted from one mature guadua angustifolia culm.

Table 5 summarizes all of the data that has gone into the SimaPro 8 model. The first section of the table describes the process of the guadua in the forest, with inputs of solar energy, carbon dioxide, and land occupation. The second segment of the table describes the felling of the guadua culm and transportation within the plantation, and includes the power sawing, gasoline, and transportation required to fulfill these processes. The final segment of the table describes the treatment and drying of the guadua, which in this model includes water, boric acid, and borax. Please see the table for greater detail and the sources for the data.

Guadua Processing Data										
Process Flows Information					One guadua angustifolia culm					
Inputs	Process Name	Outputs	Sima Pro 8 Process Name (Database)	Category/ Subcategory	Value	Unit	Data Source	Comments, Acevedo Pardo	Comments, Hernandez Londoño 2014	
Guadua Angustifolia Kunth	→ Guadua Angustifolia Standing in the Forest		Wood, Unspecified, Standing / kg (Ecoinvent)	Biotic/ Resource	73.70	kg	(Hernandez Londoño 2014) (Camargo García, 2006)	For this step, the data from Hernandez Londoño was normalized for one culm of bamboo by dividing by 6. [Each culm yields two 3-linear meter segments of guadua. For Hernandez Londoño's functional unit, she required twelve 3lm segments, extracted from 6 full culms].	"The reference data is for an average mature guadua culm, 4 to 5 years old with a 10.96 diameter, 20.38 m height, a base area of 54.07 m ² / hectare, an average density of 670 kg/m ³ and a volume of 0.11 m ³ . (Hernandez Londoño, 2014)"	
Solar Energy			Energy, gross calorific value, in biomass (Ecoinvent)	Biotic/ Resource	1381.875	MJ	(Hernandez Londoño 2014)(Daza M, y otros 2013)	the data from Hernandez Londoño was normalized for one culm of bamboo by dividing by 6.	"Calculated with the calorific power of guadua of 18.75 MJ/kg, a density of 670 kg/m ³ and a net volume of 0.66 m ³ . "	
CO ₂ Capture			Carbon dioxide, in air (Ecoinvent)	Resource/ Air	31.21	kg	(Hernandez Londoño 2014)(Arango, 2011)		"Assuming that in one hectare of 4050 guaduas there are 126.41 Tonnes/ hectare of CO ₂ , this comes o 31.21 kg CO ₂ per full guadua culm (including branches, leaves, roots, and culm)."	
Forest Occupation			Occupation, forest, intensive	Resource/ In Ground	0.0387	m2a	(Hernandez Londoño 2014)(Camargo García, 2006)	Hernandez Londoño's data was in m2, so these were multiplied by 4.5 to arrive at the m2a (meter squared* time) metric, since a mature culm is between 4 and 5 years of age.	"This number is calculated based on a base area of 54.07 m ² /hectare, calculated with the diameter (measured at chest level) and a number of culms per hectare of 6284."	
			Guadua angustifolia standing in the forest	Guadua angustifolia standing in the forest	Material/ wood/ guadua	73.7	Kg	(Hernandez Londoño 2014) (Camargo García, 2006)		"This is calculated taking into account that a guadua standing in the forest has an approximate mass of 73.7 kg..."
Inputs	Process Name	Outputs	Sima Pro 8 Process Name (Database)	Category/ Subcategory	Value	Unit	Data Source	Comments, Acevedo Pardo	Comments, Hernandez Londoño 2014	
Guadua angustifolia standing in the forest	→ Guadua Angustifolia Felled and Transported to Treatment Center		Guadua angustifolia standing in the forest	Material/ wood/ guadua	73.7	Kg				
Gasoline			Gasoline, combusted in equipment (US LCI)	Energy/ Heat/ Oil	0.032	l	(Hernandez Londoño 2014) (Lugt Vogtländer, & Berzet, Bamboo a sustainable solution for Western Europe Design Cases, LCAs and Lan-use, 2009)	For this step, the data from Hernandez Londoño was normalized for one culm of bamboo by dividing by 6. Hernandez Londoño begins to use 12 since this is the number of 3lm pieces used for her functional unit.	"This datum corresponds to the fuel used in the stages of pre-harvest, harvest and post-harvest of the guadua. That is to say it corresponds to all of the power sawing operations during this phase. Included are the motor oil and lubricating oil. The authors report 0.016 liters/ culm for which 12 total cuts are necessary."	
Power Sawing (Machine)			Power sawing, without catalytic converter {RoW} processing Alloc Def, U (ecoinvent)	Processing / Wood / Transformation	0.0833	h	(Hernandez Londoño 2014) (Althaus, Werner, Settler & Drinkel, 2007)	For this step, the data from Hernandez Londoño was normalized for one culm of bamboo by dividing by 6.	"Use of power saw for the harvest and post harvest activities. The authors report 0.4h/m ³ to extract another species of pine (Pino Paraná) with a density of 500 kg/m ³ . This datum was used to calculate sawing time for the 12 cuts for guadua at a density of 670 kg/m ³ ."	
			Wood Waste		Wood Waste	27.32	kg			
Transport			Transport, tractor and trailer, agricultural {RoW} processing Alloc Def, U (ecoinvent)			0.241	tkm	(Hernandez Londoño 2014)	Calculated by multiplying the mass of guadua to be carried (0.04638 tonnes) by the total distance traveled by the tractor (5.2 km).	"The tractor used has a capacity to transport a maximum of 100 guaduas (1.8t). It covers on average 5.2 km (2.6 km each way), and the amount of guadua to be transported is 292.32 kg."
			Guadua Angustifolia Felled and Transported to Treatment Center	Guadua Angustifolia Felled and Transported to Treatment Center	Material/ wood/ guadua	46.38	kg	(Hernandez Londoño 2014) (Humidity content: Liesel & Kumar, 2003; calculation of mass at a certain humidity: Montoya Arango, 2005).	208.8 kg/ 36 linear meters at 80% Humidity content would mean a 116 kg weight at zero humidity Content. This would then mean 3.22 kg/ linear meter at zero humidity, and 7.73 kg/lm at 140% humidity content. My calculations are for 6lm at 7.73 kg/lm.	"A humidity content of 140% is assumed based on the weight measured at the entrance to the production plant of 208.8 kg."
Inputs	Process Name	Outputs	Sima Pro 8 Process Name (Database)	Category/ Subcategory	Value	Unit	Data Source	Comments, Acevedo Pardo	Comments, Hernandez Londoño 2014	
Guadua Angustifolia Felled and Transported to Treatment Center	→ Guadua Treated and Dried		Guadua Angustifolia Felled and Transported to Treatment Center	Material/ wood/ guadua	46.38	kg			X	
Inmunization, Boric Acid			Boric acid, anhydrous, powder {GLO} market for Alloc Def, U (ecoinvent)	materials/ Chemicals/ Acids (inorganic) / Market	12	kg		The immunization assumptions are that the guadua is soaked over 4 weeks in a tank with water, boric acid, and borax. The ratios are 4 kg boric acid and 4 kg borax per 100 l of water. The solution must be changed every week. Assuming a tank whose dimensions would cover two 3 m pieces of guadua with a 11 cm diameter (.0726 m ³ which we here round to .075), 300 liters of water would be necessary over 4 weeks, with 12 kg of boric acid and 12 kg of borax.		
Inmunization, Borax			Borax, anhydrous, powder {GLO} market for Alloc Def, U (ecoinvent)	materials/ Chemicals/ Inorganic / Market	12	kg	(Schroeder, 2013)			
Inmunization, Water			Tap water, at user {RoW} market for Alloc Def, U (ecoinvent)	Materials/ Water/ Drinking Water/ market	300	kg				
			Emissions to Air/ Water		Airborne emission/ unspecified	24.7	kg			
			Guadua Treated and Dried			21.66	kg	Takeuchi 2004		After the 16 week air drying period specified, we assume a humidity content of 12%

Table 5 : Guadua Processing Data

3.2.3 Impact Assessment Results

In the *classification* step, inventory input and output data will be assigned to each category based on the relevant processes affected by each unit. The outcome of the classification step yields measures of environmental impact en masse. *Characterization* allows the data that has been classified to relate to an impact category, leading to results in terms of the selected impact categories for this study.

Guadua versus Concrete: For the impact method selected, CML-IA, the indicators were lower in the guadua than in the concrete house, as can be seen in Table 6 and Figure 11. The Global warming potential of the guadua structure is 36% that of the concrete structure; the Ozone Depletion Potential of the guadua structure is 49% that of the concrete structure, and the abiotic depletion for the guadua house was 47% that of the concrete house. The one indicator that is not significantly different is the abiotic depletion with the guadua house contributing 93% of the contributions of the concrete house. The treatment of the guadua which is the main difference between the two models weighs more heavily in this indicator. Please see

Table 7 : Top 8 Contributors to Abiotic **Depletion**.

Impact category	Unit	CML-IA baseline V3.00		
		Concrete H	Guadua H	%
Global warming (GWP100a)	kg CO2 eq	37691.41	13742.36	36%
Ozone layer depletion (ODP)	kg CFC-11 eq	0.0012	0.0006	49%
Abiotic depletion (fossil fuels)	MJ	312927.76	148490.84	47%
Abiotic depletion	kg Sb eq	0.0489	0.0455	93%

Table 6: Impact Assessment Results

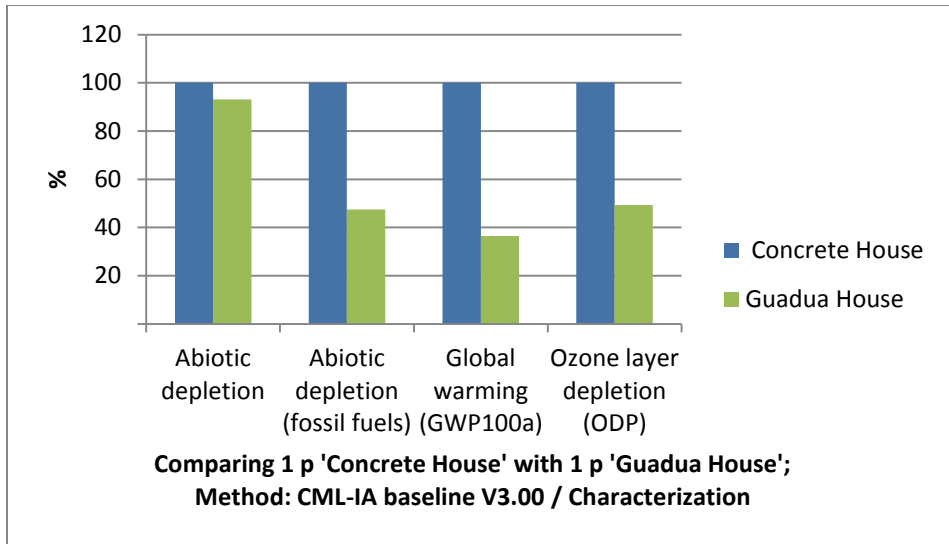

Figure 11: Impact Assessment Results Concrete vs. Guadua : CML-IA v.3

Breaking down the results of the guadua and concrete houses into their component parts, it was shown that for both cases, material transportation contributed a considerable amount to the environmental loads of the houses under study, as can be seen in Figure 12 and Figure 13.

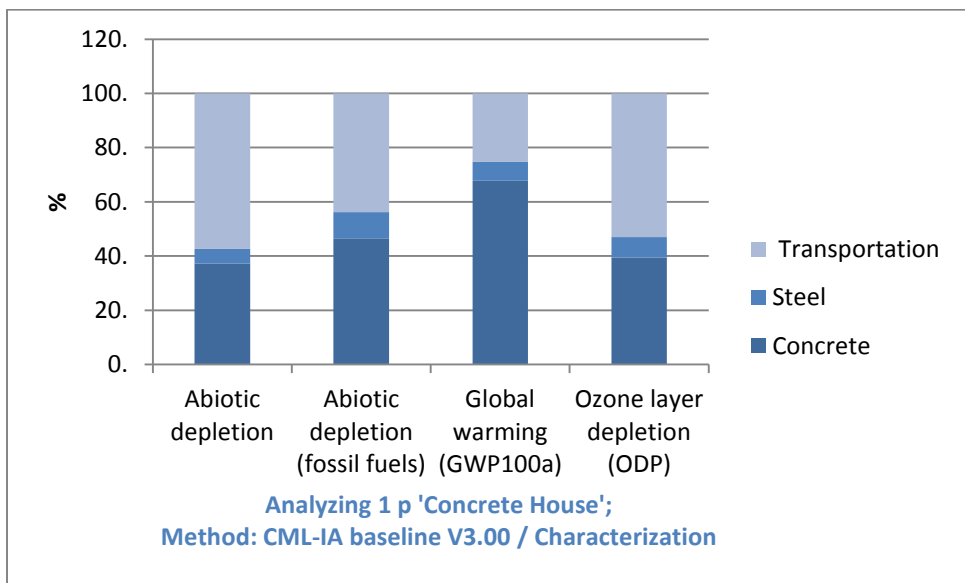

Figure 12: Impact Assessment Results Concrete House Components: CML-IA V.3

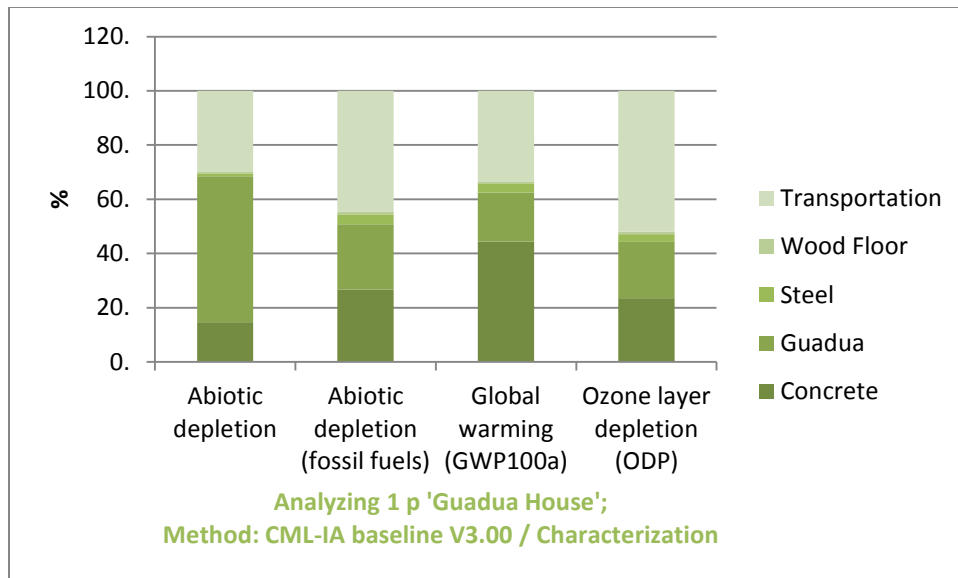

Figure 13: Impact Assessment Results, Guadua House Components: CML-IA V.3

3.2.4 Interpretation

Interpreting LCA results: The interpretation of the LCA results will lead to recommendations about the environmental impact of two main types of construction systems in Colombia.

The results presented above create a compelling case for the reduced environmental impact of guadua as a building material over concrete. The important part to highlight about this conclusion is that both the guadua house and concrete house use concrete; many of the current techniques for guadua buildings include concrete—the idea is not to substitute one material for the other because they can serve different purposes, but instead to take advantage of the properties of guadua in order to create buildings that have less environmental impacts. That being said, the normalization step was not undertaken,⁹³ and therefore the percentages shown above are not indicative of the relative

⁹³ The ISO stipulates that studies intended for public disclosure should not use normalization or weighting sets. Therefore this study has gone as far as characterization.

overall environmental impact of say, global warming versus ozone depletion and should not be interpreted as such. The conclusions that can be drawn are, for instance, that the concrete used in the guadua house contributes around 44% of the total CO₂ equivalents of the entire house, while the bamboo components contribute around 18% and the transportation of the components from the place of manufacture to the construction site contribute 33%.

Ozone depletion is associated more with the functioning of air conditioning units because of the use of ozone depleting substances as refrigerants. Seeing as this study does not include energy consumption or machinery during the life of the building, it is not surprising that the ODP levels for both cases are so low. For reference, the LEED 2009 credit on ozone depletion disregards any system that contributes less than ½ pound of CFC based refrigerants to a building. For the concrete house in this study, the ODP results indicate that it contributes 0.0012 kg eq of CFC-11, which is not even 1/1000 of a pound. This indicator is more useful when the building system under study includes HVAC systems during the operational phase of a building life cycle.

In terms of abiotic depletion, the guadua house is close to the concrete house (93%), and this is due to the fact that this indicator measures extraction of raw materials and metals. The boric acid and borax included in the model for the treatment of the guadua culms are contributing to the abiotic depletion indicator quite significantly, as can be seen in

[Table 7](#). This finding highlights the importance of the treatment of the guadua. In this case, the boric acid and borax, using the CML-IA characterization methods, are weighted more heavily in their contribution to abiotic depletion than the contribution from Portland cement or other materials in the model, which result in the close position of the guadua house to the concrete house at 93%.

		CML-IA baseline V3.00	
Top Eight Contributors to Abiotic Depletion	Unit	Concrete House	Guadua House
Boric Acid	kg Sb eq	x	0.0226
Transportation	kg Sb eq	0.0281	0.0135
Sand	kg Sb eq	0.0031	0.0025
Borax	kg Sb eq	x	0.0018
Electricity	kg Sb eq	0.0050	0.0018
Portland Cement	kg Sb eq	0.0068	0.0014
Gravel	kg Sb eq	0.0030	0.0010
Steel	kg Sb eq	0.0027	0.0005
Total of all processes	kg Sb eq	0.0489	0.0455

Table 7 : Top 8 Contributors to Abiotic Depletion

Transportation: In analyzing the contribution to each impact category based on the materials and transportation, it was found that transportation, which here includes transportation from the place of manufacture to the building site, is a significant contributor of environmental impacts. That being said, building with guadua in other parts of the Colombia outside of the bamboo growing could change the environmental impacts associated with the construction. Moreover with guadua, the drying process reduces its humidity content and weight considerably: here the guadua is assumed to be transported at 12% humidity, which corresponds to the level of humidity that is ideal for structural performance.⁹⁴ Therefore transporting the material at a different level of treatment could increase the transportation-related impacts of a guadua building.

Limitations of Current Study: There are several limitations to highlight about this study. The first is the exclusion of the concrete formwork for a cradle-to-gate life cycle assessment. Formwork is an important part of the building process in a concrete building, and its impacts are not included in the present model. For future research, the inclusion of formwork in an LCA can inform what the impacts of this construction element may be. Additionally, the current study takes as a point of

⁹⁴ Takeuchi Tam, Caori Patricia. 2004. Comportamiento estructural de la guadua angustifolia: Uniones en guadua. *Revista Ingeniería e Investigación* no. 55. (September 2004).

departure two building systems that are representative of current practice in Colombia, but are by no means the only types of construction used in low income housing. An LCA which includes other types of construction systems may highlight other important factors to consider in the construction process. Looking beyond the cradle to gate scope of this study, there would be also life cycle implications for the use phase of each of these buildings. The operational energy use in each case would be similar since there is no HVAC system to take into account; lighting and natural gas for cooking would be the main facets of energy consumption. However, bamboo and concrete have different maintenance requirements; bamboo should be kept from contact with water and sunlight to retain its structural and aesthetic characteristics, whereas concrete is more resilient to weathering. There are examples of guadua-structure buildings that are over one century old in Manizales,⁹⁵ these are made of bahareque, a construction method which encased the structural bamboo culm between two layers of flat bamboo sheets covered in plaster. In the case of this house, the exposed bamboo would need regular maintenance in order to have a life cycle like that of the concrete building. Finally, the decommissioning or deconstruction phase of the building is an important part of the LCA, and could point to new areas in sustainable architectural practice. These are all areas for further research.

Findings: Overall, the structural system of the guadua house has a lower environmental impact. It contributes 36% of the CO₂eq produced by the concrete house; and consumes around 47% of the embodied energy consumed by the concrete house. These results continue to show the environmental benefits of using guadua for construction.

⁹⁵ Jorge Enrique Robledo Castillo. *La Ciudad en la Colonización Antioqueña: Manizales*. (Bogotá: Editorial Universidad Nacional, 1996), 99-133.

4. Conclusion and Implications

The results of this analysis are compelling in that they demonstrate the potential of guadua as a building material with less negative environmental impact than concrete. There is, however, the need for further work and research in this area in order to understand the more intricate nuances of using guadua as a sustainable building material, as well as the social aspects of guadua constructions and the perception of this building material.

Environmental Issues: Guadua is a material with important environmental benefits. During its growth period, it sequesters carbon and aids in soil remediation. The five year harvest cycle of guadua makes it a rapidly renewable woody material which can potentially reduce forestry pressures if guadua becomes a more mainstream building product. In construction, the use of guadua can lead to dematerialization due to high strength to weight ratios. If used on a large scale, it can be a building material with a large impact on reducing Colombia's carbon dioxide emissions.

Social and Economic Issues: A useful mantra for understanding sustainable issues is the economy-environment-society triangle. While this study attempts to answer one aspect of the environmental aspects of building with guadua, there are both economic and social aspects that also need to be attended to. Guadua is a material that has been used in recent history for temporary structures and by very poor people. During the early 1900s when the coffee growing region began to be populated and exploited, in the instances where guadua was used for constructing houses for the wealthy, it was plastered over in order to be hidden from view.⁹⁶ The guadua house used in this study from La Divina Providencia (see Figure 9) has today been transformed, with the bamboo

⁹⁶ In person conversation with Ximena Londoño, Feb 2014.

replaced by concrete block or other more hardy and expensive materials that have a greater social prestige and the perception of sturdiness.⁹⁷ This is not an incidental circumstance; in order for guadua to be a viable option in environmental mitigation of building impacts, this social stigma must be considered, and necessary precautions and strategies taken. Furthermore, the economic aspect of guadua construction also needs attention. Economically guadua is a very inexpensive building material. However, this can make it difficult to make a lucrative enterprise from a sustainable harvesting operation.⁹⁸ These observations point to the need for greater attention to be paid to the social and economic context and systems at work in the Colombian context. Further research identifying material biases and preferences in low income populations could elucidate and perhaps help direct design interventions to make guadua a more appealing building material. The economic component of this equation is also extremely important given that any large-scale building projects will require vast amounts of this raw material.

The Construction Process: The feasibility of construction is another element that needs attention. To build with fairly untreated bamboo culms such as those represented in this study is an artisanal construction method, which would require a different approach than that which is currently taken by government entities to complete the Vivienda Gratis (Free Housing) program sponsored by the current government. Instead of large contractors bidding for a project in a distant city, local builders and perhaps even recipients of the housing units could be employed in the construction of the buildings. This approach has precedents in organizations such as Habitat for Humanity, and in

⁹⁷ In person conversation with Gilberto Florez, the Architect from the Universidad Nacional who helped develop “La Divina Providencia” project. Feb 2014.

⁹⁸ Conversation with Ximena Londoño, conversation with Juan Carlos Camargo from the UTP. From these conversations it became clear that for people who strive to harvest guadua sustainably in Colombia, it is a labor of love and patience rather than an economic enterprise, and the guadua operations are always accompanied by other agricultural products which provide a greater and more stable cash flow.

Colombia, Un Techo Por mi País, which can be sources of inspiration and examples of successful projects. Current building codes only allow for two-story guadua buildings, which might be regarded as below the required density of housing projects (which usually consist of six story buildings). Additionally, standardized bamboo products are becoming available, such as a three ply board by V&V laminados, which can be used as a building material for walls. Andrea Hernandez Londoño, who graciously shared her data for the present study, conducted a LCA of these boards, which could be used to analyze the life cycle impacts of a more processed bamboo building material versus conventional concrete and brick building.

This study has used the specific context of Colombian low income housing, which would be a practical starting point for the use of guadua in construction, with large-scale positive environmental impacts for the country. While the sustainable characteristics of the material are very compelling, it is important to keep in mind that the success of guadua depends on its availability in the market and its reception by building users—both of which are important battle-grounds. Nevertheless, the government of Colombia is in a prominent position to take advantage of this “gift of the gods”⁹⁹ in its efforts to improve the lives of the disenfranchised through sustainable building practices.

⁹⁹ Hidalgo-López, *Bamboo the gift of the gods*, 2003.

References

- Adalberth, K., Almgren A., and Petersen EH. Life cycle assessment of four multi family buildings. *International Journal Low Energy Sustainable Building* 2 (2001).
- Alexander, Lisa, Simon Allen, and Nathaniel Bindoff. Working group I contribution to the IPCC fifth assessment report on climate change 2013: The physical science basis summary for policymakers. Intergovernmental Panel on Climate Change, 5. 2013.
- H. J. Althaus, F. Werner, C. Settler, and F. Dinkel. *Life cycle inventories of renewable materials Data v 2.0*. Dübendorf, Switzerland: EMPA (2007).
- Adams, Eric, Jerome Connor, John Ochsendorf, and Rossella Nicolin, *1.964 Design for Sustainability, Fall 2006*. “Lecture 3 Current US Trends.” Lecture Slides: MIT OpenCourseWare: Massachusetts Institute of Technology, <http://ocw.mit.edu/courses/civil-and-environmental-engineering/1-964-design-for-sustainability-fall-2006>. Accessed 11 Jul, 2014.
- Arango, Ángela María. “Posibilidades de la guadua para la mitigación del cambio climático. Caso: Eje Cafetero Colombiano.” Undergraduate Thesis, Universidad Tecnologica de Pereira 2011.
- Bare, Jane C. *Developing a consistent decision-making framework by using the U.S. EPA's TRACI*. In *US EPA*. Last updated 2012. <http://www.epa.gov/nrmrl/std/traci/aiche2002paper.pdf>.
- Bare, Jane C., Patrick Hofstetter, David Pennington, and Helias A Udo de Haes. 2000. Midpoints versus endpoints: The sacrifices and benefits. *The International Journal of Life Cycle Assessment* 5 (6) (November 2000): 319-26.
- Baumann, Henrikke and Anne-Marie Tillman. *The hitch hiker's guide to LCA : An orientation in life cycle assessment methodology and application*. Lund, Sweden: Studentlitteratur, 2004.
- Bayer, C., M. Gamble, R. Gentry, and J. Surabhi. *ALA guide to building life cycle assessment in practice*. American Institute of Publishers, 2010.

Blengini G.A. Life cycle of buildings, demolition and recycling potential: A case study in Turin, Italy.

Building and Environment 44 no. 2 (2009): 319-30.

Borjesson, Pal, and Leif, Gustavsson. Greenhouse gas balances in building construction: Wood

versus concrete from life-cycle and forest land-use perspectives. *Energy Policy* 28 no.9 (2000): 575-88.

Buildings are the Problem. Architecture 2030.

http://architecture2030.org/the_problem/buildings_problem_why

CAMACOL. *Informe económico*. Bogotá: Cámara Colombiana de la Construcción (2013), 23.

Camargo García, J. C. "Growth and productivity of the bamboo species *Guadua angustifolia* Kunth in the coffee region of Colombia." PhD diss. Universität Göttingen, 2009.

Cárdenas Tamayo, Raúl Ernesto. *Pobreza y vivienda de interés social en Colombia : Los programas de vivienda urbana de la red de solidaridad social*. Santafé de Bogotá: Universidad de los Andes, Centro Interdisciplinario de Estudios Regionales, 1999.

Castells, Francesc, Oscar Ortiz, and Guido Sonnemann. Sustainability in the construction industry:

A review of recent developments based on LCA. *Construction & Building Materials* V23 no.1, 2009: 28-39.

Correal Daza, Juan Francisco, and Juliana Arbelez C. Influence of age and height position on

Colombian *guadua angustifolia* bamboo mechanical properties. *Maderas, Ciencia y Tecnología* v12 n.2, 2010: 105-113.

Daza M, C., R.W. Zwart, J.C. Camargo, R. Díaz, X. Londoño, L. Fryda, L et al. *Torrefied bamboo for the import of sustainable biomass from Colombia*. Holanda: Energy research Centre of the Netherlands ECN, Petten, (2013).

Departamento administrativo nacional de estadística (DANE). *Metodología Déficit de Vivienda, 2005*.

- Dixit, Manish Kumar, José L Fernández-Solís, Sarel Lavy, Charles H Culp. Identification of parameters for embodied energy measurement: A literature review. *Energy and Buildings Energy and Buildings* 42 no.8 (2010): 1238-47.
- Ekvall, Tomas and Anne Marie Tillman. Open-loop recycling: Criteria for allocation procedures. *International Journal of Life Cycle Assessment* 2 no.3 (1997): 155-62.
- Flores Bastidas, Camilo, Flores Bastidas, Constanza Lucia, Tsutsumi, Jun Ichiro Giorgos, Takeuchi, Caori Patricia. Approach to the load resistance in two kinds of bamboo reinforced concrete slab. *AMR Advanced Materials Research* (2011): 459-63.
- Florez, Gilberto. Trabajo de Diseno, Construccion y Direccion “Urbanizacion la Divina Providencia.” (Universidad Nacional de Colombia: Manizales, 1996).
- GBIG. “Colombia, overview.” in Green Building Information Gateway. Last modified 2014. <http://www.gbig.org/places/336>.
- Gentile, Emmanuel, Thomas H. Christensen, and Emmanuelle Aoustin. Greenhouse gas accounting and waste management *Waste Management Resources* 27 (2009): 696-706. <http://e3solutionsinc.com/home/index.php/top-resources/articles/171-biogenic-co2>
- Gilbert, Alan, Clemencia Escallon, and Beatriz Uribe. Dossier: Housing in Latin America: Revised strategies. *Revista De Ingeniería, Universidad De Los Andes*, 2011.
- Goedkoop, Mark, Michiel Oele, Jorrit Leijting, Tommie Ponsioen, and Ellen Meijer. *Introduction to LCA with SimaPro*. Pré Consultants, 2013.
- Gonzalez, M. J., N.J. Garcia Assessment of the decrease of CO₂ emissions in the construction field through the selection of materials: Practical case study of three houses of low environmental impact. *Building and Environment*, 41, 7, (2006): 902-909.
- Haes, Helias A. Udo ISO's Compromise on Comparative Assertions in Life Cycle Impact Assessment. *Journal of Industrial Ecology* v2 no.3 (1998). 4-7.

Hernandez Londoño, Andrea. “análisis de ciclo de vida aplicado a la producción de tableros de esterilla de guadua, con extracción de materia prima en la empresa Yarima guadua E.U. y producción en V&V Laminados de Guadua S.A.S., ubicadas en el eje cafetero.” Tesis de Maestría, Universidad Tecnológica de Pereira, 2014.

Hidalgo Lopez, Oscar. *Bamboo : The gift of the gods*. Bogota, Colombia : The Author, 2003.

iiSBE 2004a. Environmental framework: Annex 31 energy-related environmental impact of buildings. Canada Mortgage and Housing Corporation.

iiSBE. 2004b. Life cycle assessment methods for buildings: Annex 31 energy-related environmental impact of buildings. Canada Mortgage and Housing Corporation.

International Organization for Standardization. *Environmental Management : Life cycle assessment ; principles and framework*. Geneva, Switzerland: ISO, 2006.

“Lección 17: Mampostería Confinada.” In *Tecnología de la Construcción*. Universidad Nacional Abierta y a Distancia. Accessed July 8, 2014.

http://datateca.unad.edu.co/contenidos/102803/MODULO_ACADEMICO/leccin__17_mampostera_confinada.html

Liese, W., & Kumar, S. (2003). *Bamboo preservation compendium. Technical report 1 (INBAR technical report 22)*. New Delhi: Center for Indian Bamboo Resource Technology.

Londoño, Ximena. El bambú en Colombia. *Bioteología Vegetal* 11 no.3 (2011): 143-54.

Long Term Population Estimates and Projections 1950-2100.” *Indicators of population growth*. CELADE - Population Division of ECLAC. Revised 2013.

Mc Donough, William. *The Hannover principles: Design for sustainability*. William McDonough Architects, 1992.

- Min Ambiente. “Sea un consumidor responsable con el medio ambiente. in Ministerio de Ambiente y Desarrollo Sostenible.” Last updated 2014. Available from <http://www.minambiente.gov.co/contenido/contenido.aspx?catID=1277&conID=7745>.
- MinVivienda. *En los próximos cuatro años se construirán 300 mil viviendas gratis más y otras 200 mil para aborradores*. Last updated June 19 2014. <http://www.minvivienda.gov.co/sala-de-prensa/noticias/2014/junio/>.
- Montoya Arango, Jorge Augusto, and Carlos Alberto Orozco Hincapié. Secado solar y convencional de la guadua angustifolia. *Scientia Et Technica. Año XI* (No. 27) (April 2005): 133-8.
- Pérez-Lombard, Luis, José Ortiz, Christine Pout, A review on buildings energy consumption information. *Energy and Buildings*, V. 40, no.3, (2008): 394-398.
- Reyes, C. A., and J. A. Ramirez, Editors. Ministerio de ambiente, Vivienda y desarrollo territorial (min vivienda). Guías de asistencia técnica para vivienda de interés social no2: los materiales en la construcción de vivienda de interés social. Bogotá : Aincol, 2011.
- Robledo Castillo, Jorge Enrique. *La Ciudad en la Colonización Antioqueña: Manizales*. Bogota: Editorial Universidad Nacional, 1996.
- Rodger, Allan. 2014. UIA sustainable futures: Responsible Architecture Project. *Architecture AU*. Last Updated January 24.
- Salas Delgado, Eduardo. “Actualidad y futuro de la arquitectura de bambú en Colombia.” PhD diss., Universitat Politècnica de Catalunya, 2006.
- Schroder, Stephane. “Chemical bamboo preservation” in *Guadua Bamboo*. Bogota: Colombia, 2012. <http://www.guadubamboo.com/blog/chemical-bamboo-preservation>.
- Schroder, Stephane. “Leaching bamboo” in *Guadua Bamboo*. Bogota: Colombia, 2012. <http://www.guadubamboo.com/blog/chemical-bamboo-preservation>.

- Secretaría Distrital de Planeación (SNP). Documento tecnico soporte de la política de Construcción sostenible para bogotá D.C. Alcaldía de Bogotá, 2012.
- SETAC. *Guidelines for life-cycle assessment: A code of practice*. Brussels: Society of Environmental Toxicology and Chemistry, 1993.
- Stephenson, Michael H. *Returning carbon to nature*. Waltham, Mass: Elsevier, 2013.
- Swiss Center for Life Cycle Inventories. 2013. *Ecoinvent data base v3*. <http://www.ecoinvent.org/home> ed.
- Takeuchi Tam, Caori Patricia. 2004. Comportamiento estructural de la guadua angustifolia: Uniones en guadua. *Revista Ingeniería e Investigación no. 55*. September 2004.
- Thormark, C. The effect of material choice on the total energy need and recycling potential of a building. *Building and Environment* 41 no. 8 (2006): 1019-26.
- Unidad de Planeación Minero Energética (UPME). Normatividad ambiental Y sanitaria. in UPME. Bogotá, 2014.
http://www.upme.gov.co/guia_ambiental/carbon/gestion/politica/normativ/normativ.htm#NORMATIVIDAD_AMBIENTAL_Y_SANITARIA.
- United Nations. *Report of the World Commission on Environment and Development: Our Common Future*. World Commission on Environment and Development, 1987. Accessed July 7,2014
<http://www.un-documents.net/our-common-future.pdf>
- UPME. 2009. "Plan de expansión de referencia generación - transmisión 2009-2023." Republica de Colombia, Ministerio de Minas y Energía. Bogota: Unidad de Planeación Minero Energética.
- UPME - Ecoingeniería. Estudio *Determinación de propiedades físicas y, estimación del consumo energético en la producción, de acero, concreto, vidrio, ladrillo y otros materiales, entre ellos los alternativos y otros de uso no tradicional, utilizados en la construcción de edificaciones colombianas*. Cali: 2012.

- van der Lugt, P., A.A.J.F. van den Dobbelsteen, J.J.A.Janssen. An environmental, economic and practical assessment of bamboo as a building material for supporting structures. *Construction and Building Materials* 20 no.9 (2006): 648-56.
- van der Lugt, P., J. Vogtländer & H. Brezet .(Bamboo a sustainable solution for Western Europe Design Cases, LCAs and Land - use. INBAR Technical Report N° 30, 2009.
- Vegesack, Alexander von., Mateo Kries. *Grow your own house: Simon Velez and bamboo architecture*. Weil am Rhein, Germany: Vitra Design Museum, 2000.
- Villegas Gonzales, Felipe. “Comparación consumos de recursos energéticos en la construcción de vivienda social: Guadua vs. concreto.” Masters’ Thesis, Universidad Nacional de Colombia Sede Manizales, 2005.
- Villegas, Marcelo. *New bamboo: Architecture and design*. Bogota: Villegas Editores, 2003.
- Williamson, T. J., Antony Radford and Helen Bennetts. *Understanding sustainable architecture*. New York: Spon Press, 2003.
- Winter, Nick. “Carbonation of cement.” <http://www.understanding-cement.com/carbonation.html>