



grow with the *f*low



A Hydroponic Gardening Project

Philson A. Warner

Donald A. Rakow

Charles Mazza

Contents



- 2 Grow with the Flow—What Is It?**
 - 2 How to Use This Guide
 - 4 Supplies and Sources for Hydroponics Accessories
 - 4 Preparing for Session 1
- 5 Session 1: What Is Hydroponics**
 - 6 Preparing for Session 2
- 7 Session 1: Youth Activities**
 - 7 Activity 1: Select Crops
 - 7 Activity 2: Start Seeds
- 8 Session 2: The Physics of Water Flow**
 - 8 Preparing for Session 3
- 9 Session 2: Youth Activities**
 - 9 Activity 1: Select or Design a Hydroponic Unit
 - 10 Activity 2: Build the Unit
 - 10 Activity 3: Create a Growth Chart
- 11 Session 3: What Is a Seed? What Does It Grow Into?**
 - 11 Preparing for Session 4
- 12 Session 3: Youth Activities**
 - 12 Activity 1: Assemble the Unit
 - 12 Activity 2: Introduction to the Scientific Method
- 13 Session 4: Hydroponics and Plant Science**
 - 14 Preparing for Session 5
- 15 Session 4: Youth Activities**
 - 15 Activity 1: Compare Plant Growth
 - 15 Activity 2: Test the System
 - 16 Activity 3: Prepare the Nutrient Solution
 - 16 Activity 4: Create a Growth Chart
- 17 Session 5: Hydroponics and Plant Stresses**
 - 17 Preparing for Session 6
- 18 Session 5: Youth Activities**
 - 18 Activity 1: Change the Nutrient Solution
 - 18 Activity 2: Impose a Stress
 - 18 Activity 3: Record Growth Data
- 19 Session 6: When Pests Attack Plants**
 - 20 Preparing for Session 7
- 21 Session 6: Youth Activities**
 - 21 Activity 1: Change the Nutrient Solution
 - 21 Activity 2: Plants Attract Insects—What Attracts People?
 - 21 Activity 3: Record Growth Data
- 22 Session 7: World Food Supply**
 - 22 Preparing for Session 8
- 23 Session 7: Youth Activities**
 - 23 Activity 1: Role Play: Grocers and Customers
 - 23 Activity 2: Change the Nutrient Solution
 - 23 Activity 3: Record Growth Data
- 25 Session 8: Economics and Marketing**
 - 25 Preparing for Session 9
- 26 Session 8: Youth Activities**
 - 26 Activity 1: Change the Nutrient Solution
 - 26 Activity 2: Marketing Hydroponically Grown Produce
 - 26 Activity 3: Record Growth Data
- 27 Session 9: The Nutritional Value of Vegetables**
 - 27 Preparing for Session 10
- 28 Session 9: Youth Activities**
 - 28 Activity 1: Nutrition Quiz
 - 29 Activity 2: Analyze and Interpret a Graph
 - 29 Activity 3: Harvest and Price the Produce
- 30 Session 10: Career Choices in Plant Science**
- 32 Session 10: Youth Activities**
 - 32 Activity 1: Final Reports
 - 32 Activity 2: Prepare, Eat, and Enjoy a Salad
- 33 Appendix**
 - 33 Construction of a Horizontal Hydroponic Unit
 - 37 Construction of a Simple Plant Light Stand
 - 39 Construction of a Standing Hydroponic Unit



Grow with the *flow*—What Is It?

Grow with the Flow is a ten-session curriculum built around a hydroponic growing unit—a system for growing plants in water. In this project, you and your group will construct and set plants in a hydroponic unit, watch the plants grow, and harvest them. Although the primary focus of the project is hands-on learning about plant science, sessions also deal with entomology, social studies, marketing, human nutrition, and careers in horticulture.

The Grow with the Flow hydroponic unit is simple to construct from a standard fish tank or a plastic storage bin, PVC pipes and fittings, tubing, rock wool cubes, and a pump. Complete instructions for building two different hydroponic units are included in the Appendix.

The curriculum is most suited to middle school-aged youth, but younger and older persons can also tackle it.

How to Use This Guide

Each of the ten sessions is devoted to a separate topic. Ideally, there should be one week between each session.

Each session includes background information for group leaders or teachers and activities for youth. The background information, presented in a concise and easily understood manner, serves two purposes: it helps clarify the teacher's or leader's understanding of the scientific content, and it can be used as an outline for teaching the young people.

The background information concludes with a description of the materials and steps needed to prepare

for the next session. In this way, the leader can anticipate upcoming needs and avoid last minute crises.

The section Youth Activities includes two or three activities for youth that are related either to the construction and maintenance of the Grow with the Flow unit or to the subject matter of the session.

Some activities allow the entire group to work together, and others require individual work. The intent of all the activities is for the youths to learn while having fun. In some activities, you may find their imaginations taking off. Let them soar!

By the tenth session, the youths should be ready to harvest and enjoy the produce they have grown, ending the formal part of the project. But if sufficient interest exists, your group may want to plant new seeds and start the process again. Or they could try to set up the hydroponic growing unit in a different manner.

Session	Subject	Teacher Background	Youth Activities
1	Plant and soil science	What Is Hydroponics?	<ol style="list-style-type: none"> 1. Select crops 2. Start seeds
2	Physics	The Physics of Water Flow	<ol style="list-style-type: none"> 1. Select or design a hydroponic unit 2. Build the unit 3. Create a growth chart
3	Plant science	What Is a Seed? What Does It Grow Into?	<ol style="list-style-type: none"> 1. Assemble the unit 2. Introduction to the scientific method
4	Plant science	Hydroponics and Plant Science	<ol style="list-style-type: none"> 1. Compare plant growth 2. Test the system 3. Prepare the nutrient solution 4. Create a growth chart
5	Plant science	Hydroponics and Plant Stress	<ol style="list-style-type: none"> 1. Change the nutrient solution 2. Impose a stress 3. Record growth data
6	Entomology	When Pests Attack Plants	<ol style="list-style-type: none"> 1. Change the nutrient solution 2. Plants attract insects—what attracts people? 3. Record growth data
7	Social studies	World Food Supply	<ol style="list-style-type: none"> 1. Role play: grocers and customers 2. Change the nutrient solution 3. Record growth data
8	Marketing/math	Economics and Marketing	<ol style="list-style-type: none"> 1. Change the nutrient solution 2. Marketing hydroponically grown produce 3. Record growth data
9	Human nutrition	The Nutritional Value of Vegetables	<ol style="list-style-type: none"> 1. Nutrition quiz 2. Analyze and interpret a graph 3. Harvest and price the produce
10	Careers	Career Choices in Plant Science	<ol style="list-style-type: none"> 1. Final reports 2. Prepare, eat, and enjoy a salad

Supplies and Sources for Hydroponics Accessories

PVC pipes and fittings are generally available from hardware and plumbing supply stores. The feed line, emitters (shut-off valves), feeder tubing, rock wool cubes, and pumps are available from the following firms:

Agro Dynamics
Building #3, Navy Yard
Brooklyn, NY 11215

Crop King, Inc.
P.O. Box 310
Medina, OH 44258

Dr. Chatelier's Plant Food Co.
P.O. Box 20375
St. Petersburg, FL 33742

Eco Enterprises
2821 Northeast 55th Street
Seattle, WA 98105

Fun Water Gardens "Toronto LTD"
1134 Younge Street
Toronto, Canada M4W 2L8

Grace-Sierra Horticultural
Products Co.
Iron Run Industrial Park
6656 Grant Way
Allentown, PA 18106-9316

Great Bulbs of Fire
RD #2, Box 815
New Freedom, PA 17349

Suncor Systems
P.O. Box 11116
Portland, OR 97211

Note: No endorsement of
commercial products or compa-
nies is either intended or implied.

Preparing for Session 1

Materials You Will Need

- several full-color seed catalogs (make sure they have vegetable selections)
- copies of the "Vegetable Ballot" for each youth
- packets of vegetable seeds for each of the crops suggested in table 1
- about 40 rock wool cubes, 1 inch square
- a watertight tray

Preparation

Break the sheets of rock wool cubes into individual units.



Session 1

What Is Hydroponics?

You probably have certain assumptions about what plants need to grow:

LIGHT, certainly,

and of course AIR,

and most people would also list

SOIL, WATER, and NUTRIENTS as necessary.

But is there one item on this list that is *not* essential for plant growth?

Think about SOIL.

Most plants that you ever see, whether maples or marigolds, are growing in some sort of soil. Even water lilies in ponds have long roots that stretch through the water to attach themselves to the muddy bottom.

But did you know that in rain forests certain ferns, orchids, and plants related to pineapple extend their roots into the moist air? Or that certain pond weeds float on the surface with their roots suspended in the water?

So not all plants **require** soil to grow.

Grow with the Flow is a project in which young people learn how to grow many types of plants in a nutrient-enriched water solution. The growing process is called *hydroponics*.

You may wonder,

Why would anyone want to grow plants hydroponically?

Actually, there are several possible reasons:

1. In many locations, especially in cities, there simply isn't space or soil available to grow plants in the ground. Hydroponics allows people to grow an entire garden in a limited space, such as on a windowsill.

2. As aeronautical engineers consider the creation of a permanent space station, they must explore ways of growing food on board spacecraft. Hydroponic farming may be the cleanest and most efficient way for astronauts to grow vegetables.

3. Hydroponic gardening can be used to help solve food shortages in Third World regions, such as in parts of Africa and the Middle East, where weather conditions are unfavorable for large-scale crop production.

4. In hydroponic growing systems, water and nutrients are continually made available to the plants' roots. This allows plants to grow at the fastest possible rate, reducing the time between planting and harvest.

5. Hydroponic gardening, in projects such as Grow with the Flow, allows young people to learn about plant parts, nutrition, and stress.

Now that you know that certain plants can be grown hydroponically, your next question may be,

How does the hydroponic system replace each function that soil normally serves?

Good question!

One obvious function of soil is to support or anchor the plant, preventing it from falling over. In the Grow with the Flow unit, rock wool cubes are used to hold seedlings in place. Rock wool fibers, when compressed into cubes, have just the right density to support roots that grow into them.

Soil also functions as a reservoir of water and dissolved nutrients. Roots growing through soil absorb water and dissolved nutrients and transport them throughout the plant. In the Grow with the Flow system, a pump continuously circulates a fertilizer solution so that nutrients are always available to the plants' roots.

Outdoors, soil insulates the roots of plants from extreme cold or heat. But your hydroponic unit will be located in your classroom or home, so soil's insulating value won't be needed.

You can see that while soil is important, it is **not** essential for plant growth. On the other hand, not **all** crops can be grown in a hydroponic system.

The plants in table 1 are especially well suited for the Grow with the Flow project because

- they grow quickly,
- they can be grown under artificial light,
- they are reliable, and
- they are harvested for their leaves or stems.

This last point is important. Root crops cannot be grown in the Grow with the Flow unit because their roots will not develop in the rock wool cubes.

The plants in table 1 are mostly vegetables and herbs. Nasturtium and amaranth can be included to provide color and interest.

Table 1. Suggested Crops for the Grow with the Flow Project

Lettuce (Black Seeded Simpson, Salad Bowl, Bibb, Ruby)
Chinese cabbage (Le Choi, Mein Quin, Joi Choi)
Chinese celery
Parsley
Sweet basil
Sorrel
Nasturtium
Chives
Scallions
Amaranth

Preparing for Session 2

Materials You Will Need

Consult the instructions in the Appendix for materials needed to construct a standing or horizontal hydroponics unit.

Preparation

Consult the list "Supplies and Sources for Hydroponics Accessories" for ordering supplies to build your hydroponic unit or find local suppliers. If you plan to have your group construct the hydroponic unit this week, make sure you have adequate quantities of materials.

Session 1 Youth Activities

The list of suggested crops in table 1 includes eight different vegetables and herbs. Some of them may seem very familiar, such as lettuce and parsley, while others may be new to you, like Chinese celery.

Activity 1: Select Crops

By yourself, or in a small group, study a seed catalog to learn more about the plants suggested in table 1 for the Grow with the Flow project. Investigate

- how large each plant becomes
- whether the plant grows upright or as a vine
- what part of each plant is edible
- when each plant is ready for harvest

Your teacher or leader might ask each group to report on one plant. Then everyone can vote on which plants they would like to include in the project.

The ballot might look something like this:

Vegetable Ballot

Vote for Your Choice!

Select five vegetables:

- lettuce
- Chinese celery
- sweet basil
- Chinese cabbage
- parsley
- nasturtium
- sorrel
- amaranth
- chives
- scallions

You could decide to grow more than five vegetables, but be aware that each additional plant increases the amount of time and energy needed for the project.

You could also decide to grow a vegetable not included in table 1 (for example, a write-in candidate). Any new selections should be fast growing and should be grown for their leaves or stems.

Activity 2: Start Seeds

Your teacher or leader should have seeds for the crops that you have voted on, so you can start seeds growing today.

You will be starting the seeds in blocks of an insulation material called rock wool. Rock wool holds moisture well, fits into the openings in the Grow with the Flow unit, and does not rot or break down.

If you have selected five crops to grow, you should plan to grow eight rock wool cubes of each crop, or forty cubes in all.

Set all the cubes in a shallow tray holding 1 inch of water. In each cube, make two depressions in the top with a pen point, and in both depressions place one seed of the same crop.

Keep the tray in a warm, dimly lit location until the seeds germinate (start to grow). This may take between seven and ten days. During that time, make sure that 1 inch of water is maintained in the bottom of the tray. Once the seeds germinate, move the tray to a warm, sunny spot, such as a windowsill.

Session 2

The Physics of Water Flow

Does water flow ^{UP}?

Of course it does not.

This creates a problem, because the water in the Grow with the Flow system must travel upward to the plants before it falls back into the tank under the force of gravity.

The solution to the problem is to use energy to force the water upward. The energy comes from a pump.

The pump gets its energy from electricity.

The electricity may be generated by a powerful waterfall turning a mighty turbine. So falling water has the potential to do work.

In fact, the exact amount of energy it takes to pump a quantity of water from a tank to the top of a tube is released as the water flows spontaneously back to the tank.

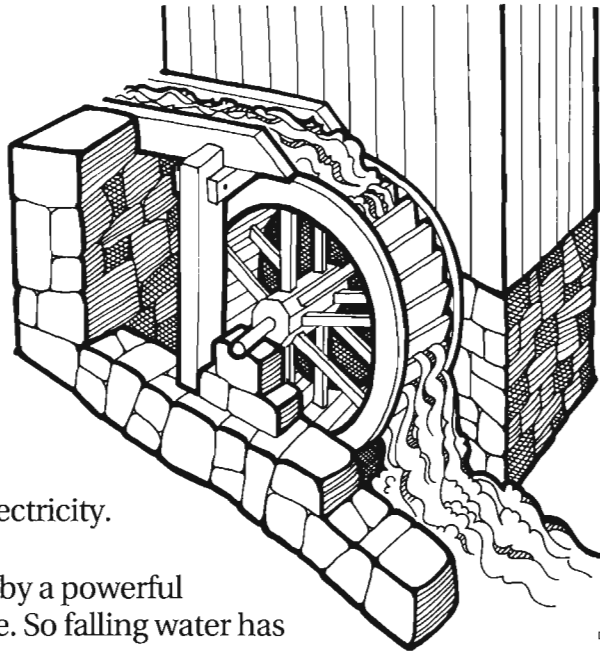

Preparing for Session 3

If all the materials needed to construct the Grow with the Flow unit and to create the growth charts were on hand for Session 2, then no new materials are needed for Session 3.

Session 2 Youth Activities

Now that you understand how water flows with and against gravity, you are ready for an exciting session because you will actually design and begin to construct a hydroponic unit. The actual unit your group constructs will depend on the time that is available, the materials that you have, and how ambitious you are!

Activity 1: Select or Design a Hydroponic Unit

Figures 1 and 2 depict two possible designs for a Grow with the Flow unit. The upright hydroponic unit (fig. 1) stands 48 inches tall and is intended for a location where there is a lot of space and plenty of natural light. There are 19 grow ports on this unit.

Figure 2 shows a horizontal hydroponic unit for use under artificial light. Because all plants are the same distance from the light stand, growth is very uniform.

Your group does not have to select one of these two units. But any unit you design yourselves must have these essential parts:

- a catchment tank, to hold water
- a pump, to pump the water from the catchment tank
- 1/2-inch feed line, to transport the water from the pump to the hydroponic unit
- PVC pipes and fittings (straight sections, joints, elbows, Y sections, and T sections), to provide a framework and to allow the water to flow back into the tank by the force of gravity
- spaghetti (feed) tubing with shut-off valves (emitters), to deliver the water to the plants

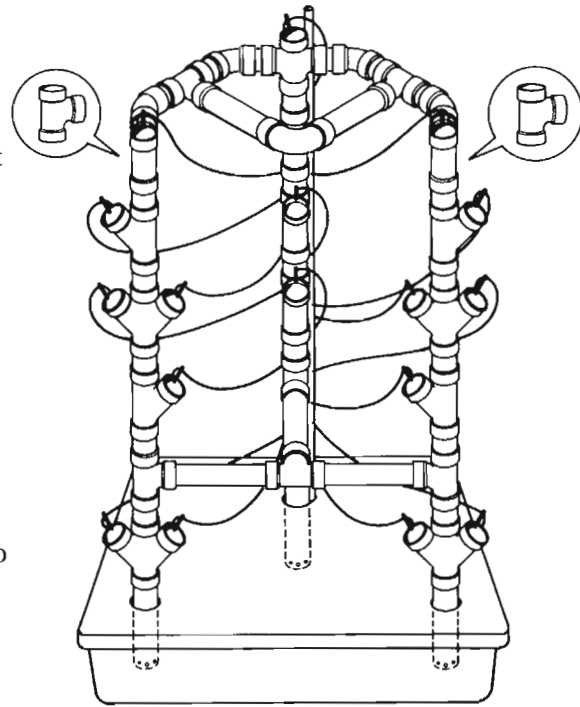

HOUGHTON

Figure 1: Standing hydroponic unit

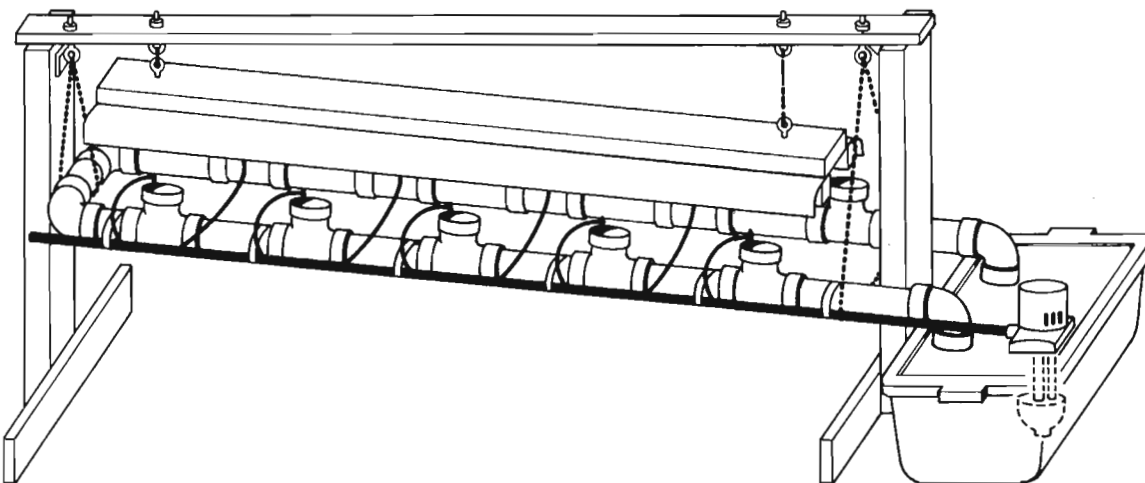

HOUGHTON

Figure 2: Horizontal hydroponic unit with light stand

Activity 2: Build the Unit

All hydroponic units are based on the nutrient drip flow technique, whereby a nutrient solution is pumped from a catchment tank, drips to the root zones of the plants, and ultimately returns to the catchment tank under the force of gravity.

To begin construction of your unit, review the PVC pipe sections and fittings you will need, which are listed in the instructions in the Appendix. Include all straight sections, T sections, Y sections, joints, and elbows.

From this list, and under the supervision of your teacher or leader, you can start to cut out the needed sections.

Do not glue together any pieces at this time.

Once all the pieces have been cut out, assemble the unit without cementing any joints. Use the figures in the Appendix as a guide. If any pieces do not fit properly or are too long or short, recut new sections.

If time permits, under the teacher's or leader's supervision, you may cement the sections together into a finished unit.

Activity 3: Create a Growth Chart

Once you have planted your crops into the Grow with the Flow unit, you will be asked to record the growth of each plant each week. Prepare for this activity by developing a growth chart now. The chart should be on a piece of graph paper that is pasted to a piece of construction paper. Across the left-hand vertical axis of the chart, each hash mark should represent 0.5 cm of growth. Across the bottom horizontal axis, each hash mark should indicate one week.

Consult the sample chart in figure 3 if you need help constructing your growth chart.

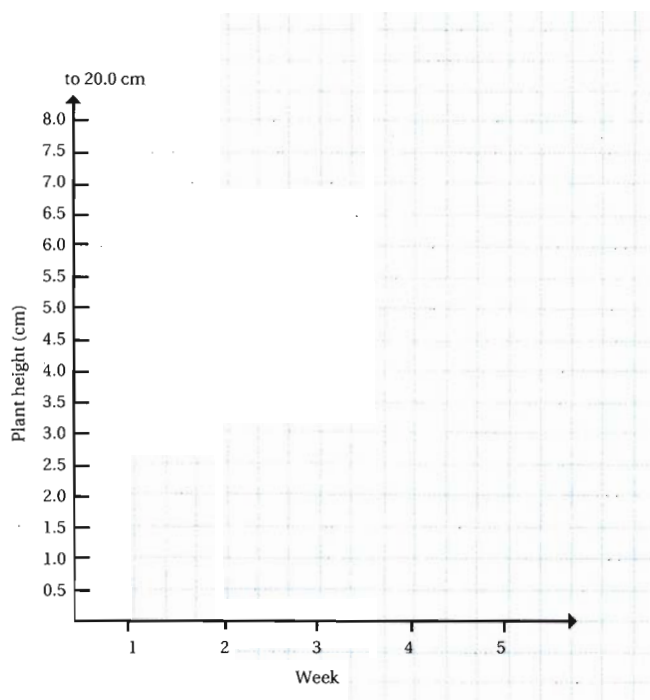

Figure 3: Sample growth chart



Session 3

What Is a Seed?

What Does It Grow Into?

For those of you tired of the chicken-egg debate, try this puzzler for a change:

Which came first, the PLANT or the SEED?

Every plant started as a seed, every seed developed on a plant.

While puzzling over that, consider this: a seed is nature's most perfect space and time capsule. It is capable of traveling undamaged for hundreds of miles and can, in some cases, germinate after thousands of years. Ancient lotus seeds found in the pyramids of Egypt, for example, have sprouted and grown into healthy plants.

So what is a seed?

As shown in figure 4, a seed is a baby plant (the *embryo*) that is nourished by a stored food supply (the *cotyledons*) and protected by an outer layer (the *seed coat*).

In Session 1, you learned that all plants need water, light, air, and nutrients to grow. As they germinate, or start to grow, seeds need water and warmth to break their dormancy. Some seeds also need light, but most germinate best in the dark.

As a seed germinates, the embryo pushes through the seed coat, using energy stored in the cotyledons. Once the seedling emerges above ground, it begins to grow its own stem, leaves, and roots, and the cotyledons shrivel up.

As the seedling grows, it develops the structures that it needs to become a mature plant:

- The *xylem vessels* are made up of specialized cells for transporting water from the roots, through the stems, and out to the leaves.
- The *phloem tubes* are a second transport system for moving food produced in the leaves to other portions of the plant.
- The *root system* is responsible for anchoring the plant, absorbing water and mineral nutrients, storing food reserves, and synthesizing many organic materials.

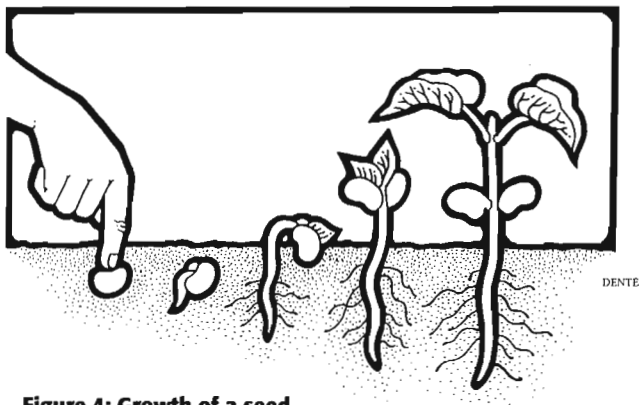
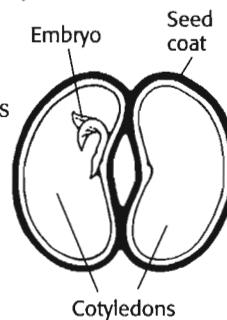

Figure 4: Growth of a seed

Preparing for Session 4

Materials You Will Need

- 4-inch clay or plastic pots
- potting soil
- hydroponics fertilizer
- a container with a tight-fitting lid
- a balance or a scale
- a 1-tablespoon measure
- graph paper
- poster board
- color markers
- rulers

Preparation

Go over the steps involved in mixing the fertilizer solution described in Activity 3.

Session 3 Youth Activities

In Session 2, your group cut out the needed sections of PVC pipe and assembled the Grow with the Flow unit without cement. Today you'll glue your unit together.

Activity 1: Assemble the Unit

Assemble the Grow with the Flow unit again (without cement), and make sure that it matches the diagram that you are using as a guide. Do all the pieces fit well together without being bent or forced? If so, you are ready (with an adult's help) to cement the sections together. Once the unit is assembled, let the newly cemented joints cure for 12 hours.

Activity 2: Introduction to the Scientific Method

Have you ever wondered how scientists get answers to the questions that concern them? They use a standard, time-tested process called the *scientific method*.

Here is how the scientific method works.

Step 1: Form a hypothesis

A hypothesis is a scientist's best guess at how something should occur. Often a scientist will start out with a broad research hypothesis and then develop one or more specific test hypotheses.

For example, in Session 3 you were told that all seeds need warmth and water to germinate, or start to grow. To examine one part of this statement, your research hypothesis might be, "All seeds need a source of moisture to germinate." A more specific test hypothesis could be, "Seeds deprived of a source of water germinate at a lower rate than seeds of the same type provided with a source of water."

Step 2: Set up an experimental design

The experimental design should be based on the test hypothesis. Continuing with the example above, you could design an experiment in which you divide a single lot of seeds in half. You would set one-half of the seeds into pots with a dry soil mix. You would set the other half into pots of the same size and the same soil mix, but you would keep the soil moist. The soil moisture level would be the *variable* in this experiment.

Step 3: Observe, record data

Before beginning any experiment, you should decide what you plan to observe. The information that you record about what you have observed is called *data*.

In this experiment, you would be interested in observing the rate and relative success of germination in both the dry and the moist soils.

You can turn your observations into data by creating a chart that lists days along one axis and the number of seedlings that have germinated along the other axis, as illustrated in figure 5.

Step 4: Draw a conclusion

A conclusion can only be based on what you observe and the data you record. The data shown in figure 5 leads to a single conclusion: seeds deprived of a source of water germinate at a lower rate than seeds of the same type provided with a source of water. Your test hypothesis is correct.

This conclusion also indirectly supports your original research hypothesis.

Figure 5. A data chart

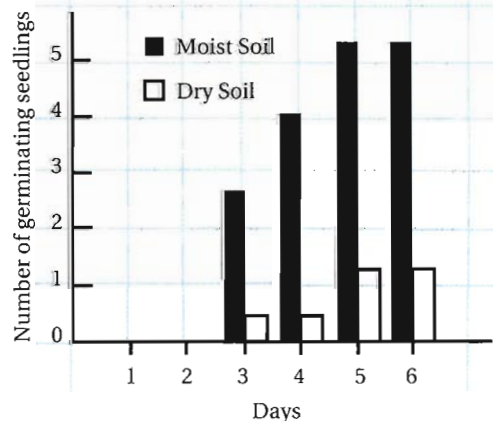

Session 4 Hydroponics and Plant Science

In Session 1, it was established that plants do not require soil to grow.

But, what is plant *growth* ?

To grow is to increase in size, and plants grow when their cells

- expand,
- divide, and
- differentiate (become specialized).

Do you know how plants get the energy to grow?

They combine sunlight, carbon dioxide, and water to produce food and oxygen.

This process, which takes place mostly in the plant leaves, is called *photosynthesis*.

Plants are the only organisms that produce their own food. What talent!

To release energy, plants break down sugars produced by photosynthesis.

This process is called *respiration*. Some of this energy is then used to build

- proteins,
- starches,
- cellulose,
- fatty acids, and
- other building blocks of plant cells.

Respiration goes on continuously in all living cells, in all plants and animals. Living organisms depend on respiration to get energy.

Consider a food web:

A **wolf**, to get food energy, may eat a **rabbit**. A **rabbit**, to get food energy, may eat **clover**.

Clover, to get food energy, **photosynthesizes**. To **photosynthesize**, clover must have carbon dioxide, sunlight, and water.

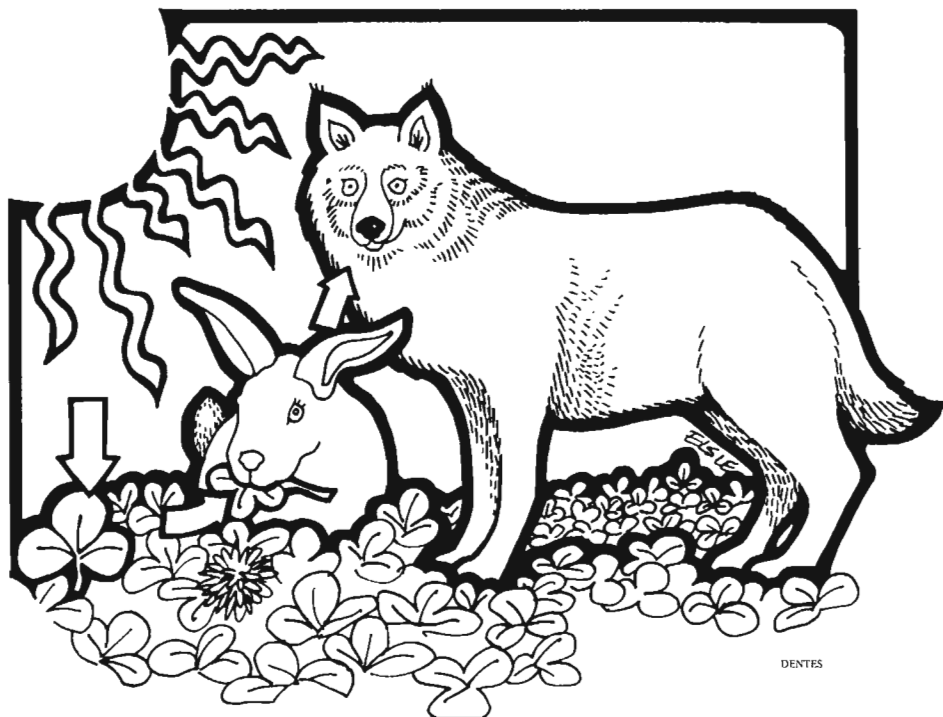

Therefore, all life on our planet depends on the photosynthesis formula:

carbon dioxide + water + solar energy → food + oxygen

Relating this formula to the Grow with the Flow project, you can see that your hydroponic unit provides plenty of water, and indoor air provides enough carbon dioxide, but **what about solar energy?**

You can provide natural solar energy by placing the Grow with the Flow unit close to a sunny window. Or you can suspend artificial lights, such as fluorescent tubes, over the setup. Either way, the energy from light will power photosynthesis.

The chemical formula for photosynthesis is

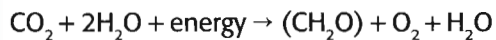

In any chemical equation, the number of atoms of each element must be equal on both sides. That is, they must balance. In the formula for photosynthesis, there are 1 carbon, 4 hydrogen, and 4 oxygen atoms on the left-hand side and the same number of atoms for each element on the right-hand side.

There are many products on the market that are advertised as “plant foods.”

Are “plant foods” food for plants?

You now know that plants manufacture their own food in their leaves. They do not take up food through their roots.

The more correct name for those commercial products is *plant fertilizer*. Plant fertilizers contain various minerals that are essential to plants. Most fertilizers contain the minerals nitrogen, phosphorus, and potassium. Because plants use large quantities of these nutrients, they are referred to as *macronutrients*.

Many fertilizers also contain smaller quantities of *micronutrients*: iron, copper, manganese, zinc, molybdenum, boron, nickel, chloride, calcium, magnesium, and sulfur.

The essential minerals are involved in

- building cells and the constituents of cells,
- regulating the operation of cells, and
- developing enzymes, which regulate the rate of chemical reactions in the cells.

In the Grow with the Flow system, carbon, hydrogen, and oxygen are supplied by the air. The other macro- and micronutrients are supplied by the fertilizer solution.

Together, the macro- and micronutrients in solution make up a **balanced fertilizer**, which means the solution provides the correct concentrations of mineral nutrients for plant uptake.

Preparing for Session 5

Materials You Will Need

- two coleus plants in 3- or 4-inch pots (you may substitute impatiens, or tomato or pepper seedlings)
- color markers or crayons

Preparation

Do not water the plants for one day **before** your group is to use them. Have labels available to mark the plant that will be well watered and the one that will be stressed.

Session 4 Youth Activities

This is it, the week you finally get to set up the Grow with the Flow unit with growing plants. You also are going to use what you learned last week about the scientific method to compare hydroponic growing with growing plants in soil.

Activity 1: Compare Plant Growth

Do you think plants grow more rapidly in a hydroponic unit or in pots filled with soil?

To examine this question further, try writing it down as a test hypothesis:

Based on the test hypothesis, you will set up an experimental design.

For each type of plant you have grown in the rock wool plugs, set four of those plants in grow ports in the Grow with the Flow unit and four in individual 4-inch pots.

Note: Do not remove the seedlings from the rock wool plugs! The plugs should fit snugly into the individual grow ports. To set your plants in pots, place enough soil mix into the bottom of each pot so that the top of the rock wool plug sits just below the top of the pot. Then fill in the pot with more soil around the plug.

Now go on to Activity 2.

Activity 2: Test the System

Now that the cement is cured, you can add the feed line and tubing and test the system. The feed line carries water from the pump in the catchment tank to the hydroponics unit. The plant feeder tubes are each connected to the feed line at one end and a shut-off valve (emitter) at the other end. The actual arrangement of the feeder tubes varies with the type of unit.

Fill the catchment tank halfway with tap water. Then attach the feed line to the pump. Fill each grow port with a rock wool plug and set the end of the plant feeder tube with the emitter onto each rock wool plug. You may need to clip the emitters to the grow ports.

To test the system, turn on the pump. Check to see if water is flowing through the feed line, out to the plant

feeder tubes, and back through the PVC pipes into the catchment tank. Look for leaks anywhere in the system. These indicate spots that need more cement.

Your Grow with the Flow unit is now ready for full operation.

Activity 3: Prepare the Nutrient Solution

There are many soluble hydroponic fertilizers on the market. Most contain macronutrients and micronutrients in an “A” powder and calcium nitrate in a “B” powder. Add the amount recommended on the packages of each powder to a known volume of water. Then use this solution to fill the catchment tank.

Make sure that the emitter end of each plant feeder tube sits on a rock wool plug. (It can be held in place with paper clips or special stabilizer pegs.)

Now, turn on the system!

At the same time, water each potted plant with a solution of the fertilizer. Repeat this fertilization every three days.

Do not water the pots between fertilizations.

Activity 4: Create a Growth Chart

The next step in your experiment is to **observe** the plants and **record** data. In Session 2, you created a growth chart for the plants in the Grow with the Flow unit. Now create a second growth chart for the potted plants. Use figure 6 as a model.

From the steps in the scientific method, you know that after forming a hypothesis, you develop and carry out an experimental procedure. The third step is to make observations and record data. You can start on the third step now.

For each plant type that you are growing, choose a marker or crayon with a distinct color. In the Grow with the Flow system,

calculate the average plant size for each type of plant. You can do this by measuring the plant height, or the number of leaves, or the average plant width. Record this data on the chart with the color markers. Next, do this for each plant type growing in the pots.

You will call these records your base data, because the measurements were taken before the “treatments” (growing plants in a hydroponic unit versus growing plants in potted soil) could affect how the plants grew.

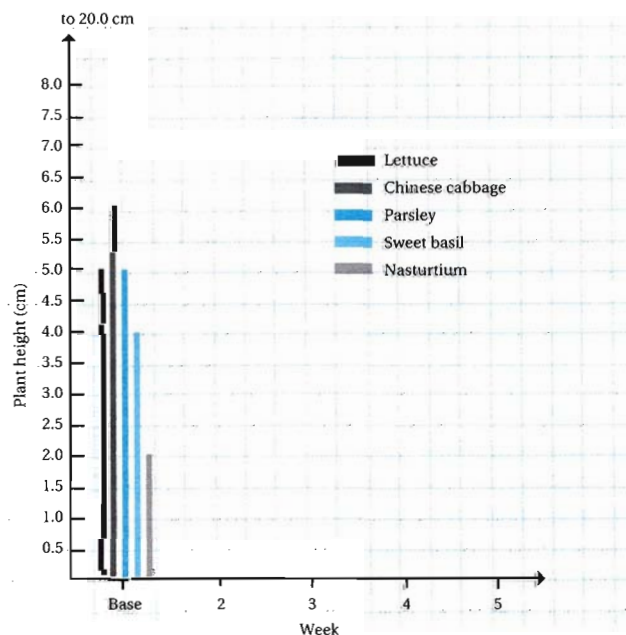

Figure 6. Sample growth chart for potted plants, week 1

Is chocolate bad for you? How about coffee, or table salt?

Unless you are on a medically restricted diet, none of these foods are unhealthy in small quantities.

Problems arise, however, when people eat too much of certain foods, such as sweet or salty items.

In a similar manner, plants must not take in too great a quantity of particular nutrients.

Excess quantities of nutrients, taken up through the roots, can be toxic to the plant, interrupting vital processes or preventing other nutrients from being available.

In soils with very low pH levels (acid soils), iron and aluminum can each be present at potentially toxic levels. In alkaline soils (high pH levels), chloride and molybdenum can occur at overly high concentrations.

High concentrations of salts in the soil can make it more difficult for plants to take up water. When salts move into the leaves, leaf burning or browning may result.

But fear not. Grow with the Flow gardeners are protected from these problems. The fertilizer solution described in Session 4 provides just the right quantity of each nutrient, so plants are neither starved nor overdosed. Also, the pH of the solution is maintained in the proper range so that toxicity problems are avoided.

Plants need more than nutrients to survive. They also need lots of water. Plants use water to remain turgid (upright), to circulate nutrients, food, and hormones, and to *transpire*. In transpiration, plants lose water vapor through pores in the leaves. Leaves are cooled by transpiration.

When plants do not receive enough water, their leaves and stems wilt, or the leaves turn brown and fall. In extreme cases, growth is slowed or plants die. How sad.

In the Grow with the Flow system, water is constantly available. So plants grow at the fastest possible rate, with none of the wilting or burning associated with water stress.

The result: larger, more attractive plants.

Preparing for Session 6

Materials You Will Need (Optional)

- a guide to insects of North America
- a mounted insect collection
- pictures of insects from magazines or advertisements
- color markers or crayons

Preparation (Optional)

Using a guide, familiarize yourself with the parts of an insect and some of the more familiar insects in your area. If you are able to borrow a mounted insect collection, you can use it to show your group the body parts of an insect. Otherwise, you can work from photographs or illustrations.

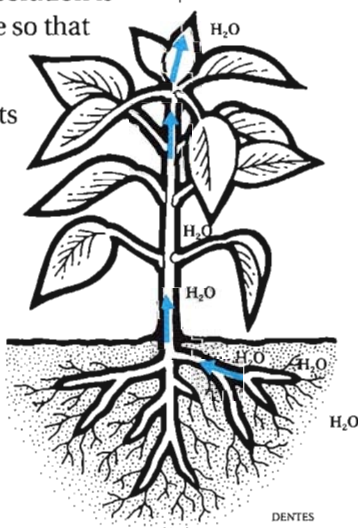

Session 5 Youth Activities

Your plants have had one week to grow and develop in the Grow with the Flow unit and the pots. Do the plants look different? If so, in what ways?

Activity 1: Change the Nutrient Solution

The nutrient solution constantly circulates through the Grow with the Flow pipes and tubes. As it does this, some of the nutrients are taken up by the roots of the plants. Over time, the solution becomes weaker, or has a lower concentration of dissolved nutrients.

In addition, some fertilizer salts settle on the rock wool plugs. These deposited salts can build up to levels that can eventually damage the plants' roots.

This week you will deal with both of those potential problems by flushing the system. Next week you will add a new supply of nutrients.

Turn off the pump and remove it from the catchment tank. If your hydroponic unit sits in the catchment tank, lift it out and set it on a table. Then carefully dump the solution from the tank into a sink. Wipe out the inner walls of the tank with a damp sponge.

Next, fill the tank halfway with tap water. Set up the system again, circulating the clean water through the pipes and tubes. This will flush out deposited salts over the next seven days.

Continue to water the plants in the pots with the nutrient solution every three days.

Activity 2: Impose a Stress

Your teacher or leader will have two coleus (or other) plants, each in its own pot. Have someone in your group water one of the plants until water drains through the bottom of the pot. Give no water to the other plant. Set the plants on a sunny windowsill.

Every other day, give the first plant a heavy watering and the second one no water. Eventually, the plant not watered will wilt.

Guess how many days it will take for the stressed plant to wilt. Your teacher or leader will record the number of individuals who guess each number of days.

Activity 3: Record Growth Data

Using the same method you used to determine the base growth data, calculate the average plant size for each plant in the Grow with the Flow unit and then for each plant grown in soil.

Record this data on the growth charts using the color markers or crayons (fig. 7).

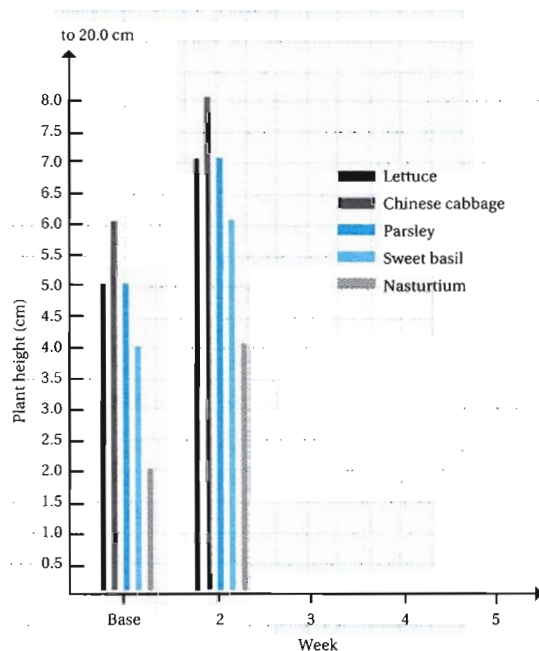

Figure 7. Sample growth chart for potted plants, week 2

Session 6 **When Pests Attack Plants**

What is a plant pest?

In agriculture, a pest is something that interferes with the yield expected from plants. This session will concentrate on insects.

Pests can attack plants at different stages of plant growth. The term used to describe plant-feeding insects is *phytophagous* (fi-toff-a-gus).

An insect feeding on a plant uses the plant for food, and usually the plant does not benefit from being fed upon. This is called an *antagonistic relationship*. The insect gains food for its growth and development at the expense of the plant.

Insects feed on plants in two basic ways, depending on the mouthparts the insects have.

1. Chewing insects eat plant parts, removing solid portions of plant tissue and causing holes, notches, or the *skeletonization* of leaves, where nothing is left but leaf veins.

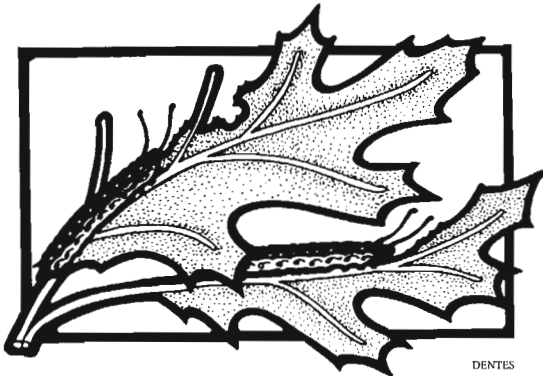

2. Sucking insects feed on plant sap; they penetrate the plant tissue and drink up fluids.



Some insects are very specific and feed only on one type of plant, while others feed on a number of different plants.

How does an insect find a host plant?

Scientists have discovered that plants give off *chemical cues* and that these cues can become airborne. Insects may be attracted or repelled by different chemical cues. When an insect reaches a plant surface, other chemical cues on the surface may stimulate the insect to feed or possibly to lay its eggs on the plant, or it may repel the insect.

Once an insect has found an acceptable host plant, other factors determine whether it can be called a pest. For instance,

- Are the parts of the plant that the insect attacks the same parts you want to harvest and eat, such as the leaves (lettuce, Chinese cabbage), the roots (carrots, radishes), or the seeds (peas, grain crops)?
- How much injury is the insect actually causing, and how many insects are there?
- Is the injury occurring at a time when the plant can outgrow it?
- Are environmental conditions affecting the plant's ability to withstand injury?

The stage of growth the plant is in when the insect attacks is important.

Seedlings are very susceptible to injury. Just one bite into the stem from an insect could cause the death of the entire plant.

Young plants grow vigorously, and they may be able to outgrow some insect injury.

As the part of the plant that you want to harvest is being formed, it can be very susceptible to insect injury. In this project, for example, you will harvest the leaves and stems of the plants you grow. If an insect were to attack just a few outer leaves, damage would not be very severe. If it were to bore into the center leaves as well, however, the plant could be ruined.

When the plant is mature, it is usually tougher and less susceptible to attack by some insects. Scientists also believe that when a plant is under nutrient stress, it is less able to withstand pest attack. Therefore, it is a good practice to keep plants growing well and vigorously through proper fertilization and watering. When a plant is under stress, its energy goes toward fighting the cause of the stress, and little is left to fight insects that may attack it.

Preparing for Session 7

Materials You Will Need

- copies of the activity sheet "Fruits and Vegetables" for each youth
- color markers, crayons, or water colors

Preparation

Review Activity 1, "Role Play: Grocers and Customers" (page 23). Think how you can assist the groups so the activity proceeds successfully.

Session 6 Youth Activities

Activity 1: Change the Nutrient Solution

The plants in your Grow with the Flow unit have been growing in plain water for one week. Now, they need a ready supply of nutrients again.

Turn off the pump and remove it from the catchment tank. If your hydroponic unit sits in the catchment tank, lift it out and set it on a table. Then

carefully dump the water from the tank into a sink.

Next, fill the tank halfway with fertilizer solution, as you did in Session 4, Activity 2. Then start up the system with the new solution in the catchment tank.

Continue to water the plants in the pots with the nutrient solution every three days.

Activity 2: Plants Attract Insects—What Attracts People?

You have just learned that plants give off chemical cues that can attract (or repel) insects. But in your Grow with the Flow garden, you may not find any insect pests. Why not? (Clue: *How is this environment different from the natural environment?*)

If you were to find insect pests on some of the plants in the Grow with the Flow unit, what would you do (besides using chemicals to kill them)?

Humans also are attracted to some things and repelled by others, often based on the information they get from their nose. Can you think of items that your nose tells you to be attracted to?

Can you think of items that your nose tells you to stay away from?

Humans also use their eyes to determine whether they are attracted to something. What items do your eyes tell you to be attracted to?

What items do your eyes tell you to avoid?

Activity 3: Record Growth Data

Using the same method you used in the previous session, calculate the average plant size for each plant in the Grow with the Flow unit and then for each plant grown in soil.

Record this data on the growth charts using the color markers or crayons.



Session 7

World Food Supply

Imagine a pool of water, teeming with fish and sources of food for the fish.

Now imagine a second pool. It is almost dry and, although many fish are still in it, almost no food is available.

Humans on the planet Earth suffer from the same problem—lots of food available in one part of the world, very little grown or available elsewhere.

What factors determine the availability of food in a region?

- **Climate** is a major factor. In arid or dry parts of the world, such as the deserts of the Middle East and parts of Africa, it is difficult to raise crops or livestock because water is so scarce. Rain forests, on the other hand, are so wet much of the year that if soils are not properly managed, they can easily wash away, along with the crops that are growing on them.
- **Technology** is also important. The United States, Canada, and many other nations have adopted agricultural techniques that allow them to grow a large amount of grain, fruit, vegetables, or livestock on an acre of land.

Such high-production techniques, however, may not be appropriate for many less-developed nations.

Why?

Because the costs of equipment, fertilizer, and fuel may be too high for local farmers. Or the varieties of seed or livestock needed for high-production farming may not be available. Or the techniques may run counter to cultural or religious practices in a region.

Every year many thousands of people starve to death around the world. Sending food to needy regions is one way to help reduce starvation. But, unfortunately, that is only a temporary solution.

To have a long-term impact, countries that currently have food crises must adopt farming techniques that are

- effective in increasing yields,
- based on available resources,
- affordable to local farmers, and
- acceptable to the local culture and religion.

In some regions, hydroponics may be an acceptable alternative means of growing crops. Possible limiting factors may be the cost and availability of electricity and the availability of PVC pipes and rock wool.

Working out such limitations is a challenge for the future.

Preparing for Session 8

Materials You Will Need

- poster board
- color markers or crayons
- scissors, tape

Preparation

Review Activity 2 (page 26) and think of ideas for marketing hydroponically grown produce. Your ideas will help the youths who have trouble thinking of their own marketing concepts.

Session 7 Youth Activities

Activity 1: Role Play: Grocers and Customers

In the United States, people usually spend money to purchase items. In other countries, trading or bartering is a common practice.

This exercise lets you think about things of value—other than money—that you might be able to barter.

Cut out the fruits and vegetables on the activity sheet, and then use crayons, color markers, or water colors to color the produce as realistically as possible.

Divide into groups of four. In each group, two persons will be grocers and two will be customers. The grocers should hold all the produce cards.

With your group, conduct the following role play.

The scene: Two customers have just entered a grocery store **very hungry**, but they have no money. The store is staffed by two grocers.

Customers (sitting opposite the grocers): Think of services or goods that you could trade for some of the tasty produce, for example, one hour of stocking shelves or cleaning the windows of the store. Offer one to the grocers.

Grocers: After an offer, consider how much produce the customers' offer is worth. Then transfer that many produce cards to your hungry customers.

Customers: Repeat the bartering until you decide you are no longer hungry.

Activity 2: Change the Nutrient Solution

The plants in your Grow with the Flow unit have now been growing in the nutrient solution for one week. The system needs to be flushed again.

Turn off the pump and remove it from the catchment tank. If your hydroponic unit sits in the catchment tank, lift it out and set it on a table. Then carefully dump the solution from the tank into a sink.

Wipe out the inner walls of the tank with a damp sponge.

Next, fill the tank halfway with tap water. Set up the system again, circulating the tap water through the pipes and tubes. This will flush out deposited salts over the next seven days.

Continue to water the plants in the pots with the nutrient solution every three days.

Activity 3: Record Growth Data

Using the same method you used in the previous sessions, calculate the average plant size for each plant in the Grow with the Flow unit and then for each plant grown in soil.

Record this data on the growth charts using the color markers or crayons.



Fruits and Vegetables

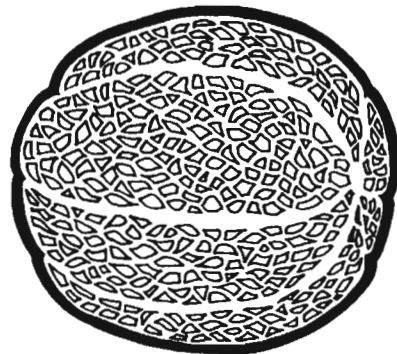
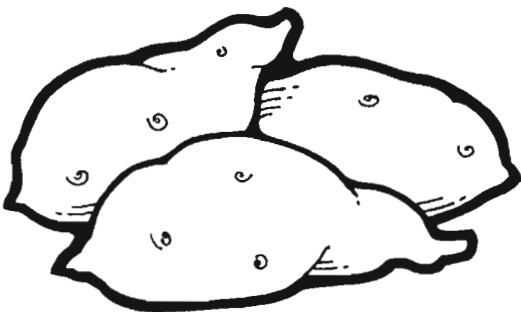
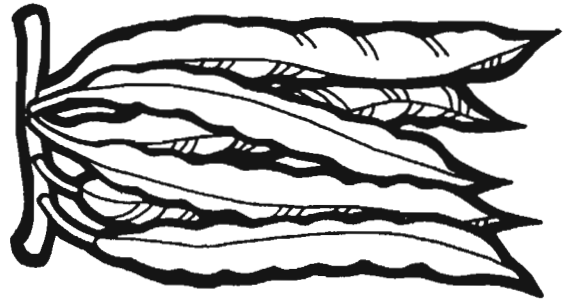
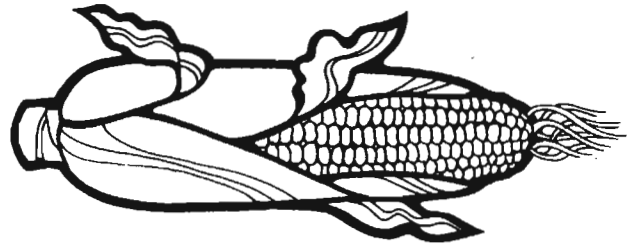
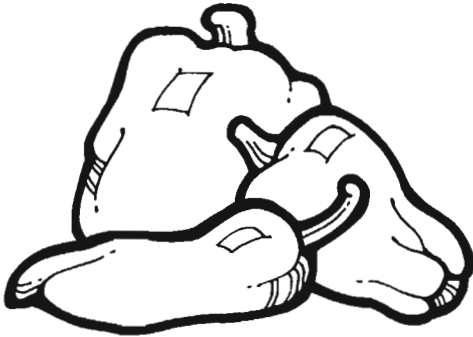
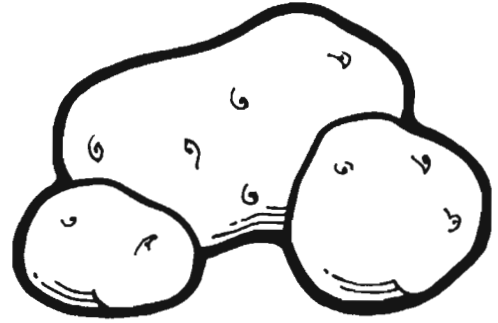
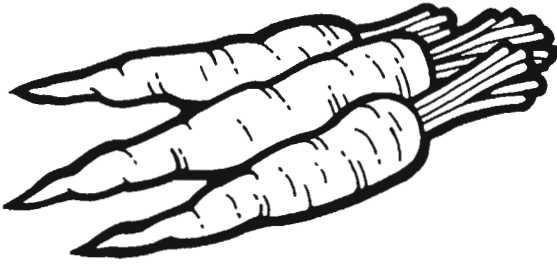

Session 8 **Economics and Marketing**

Now that you know how easy it is to grow food hydroponically, consider how farmers **SELL** what they grow.

Think about where you buy the produce that you use.

It might be at a *supermarket*, or at a *produce store*, or at a *farmers' market*.

The vendors at a farmers' market probably grow most of what they sell. **But what about the supermarket or produce store manager? From where do they get their produce?**

Oranges might come from Florida. Bananas might come from Brazil. And lettuce might come from a hydroponics greenhouse.

Do you think that hydroponically grown vegetables and herbs cost more or less than food grown in soil?

With hydroponics, you can grow a lot of food in a small amount of space in a short time. That **should** keep the cost of hydroponically grown produce low.

But hydroponically grown food is comparatively more expensive.

Why is that?

Actually, there are two reasons hydroponically grown produce brings a top price.

The first is *market demand*. Consumers recognize that hydroponically grown vegetables and herbs are of high quality, and they are willing to pay more for that. But they have to be shown that hydroponically grown produce is special. Hydroponics growers and marketers do this by using special types of labels as well as padding to prevent bruising in transit.



DENTES

The second reason hydroponically grown produce brings a top price is *availability*. Hydroponics greenhouses can supply fresh produce year-round. In the Northeast, a ripe, red tomato may not be worth very much in August, but in January it is golden. So hydroponics growers can make their greatest profits at times of the year when the market is not flooded with local vegetables and herbs.

So you can think of hydroponics growers as farmers. Only the fruits of their farms are most likely to be trucked to a specialty retailer, a high-quality restaurant, or a resort.

Preparing for Session 9

Materials You Will Need

- copies of the Nutrition Quiz for each youth

Preparation

Select a local market that sells the crops your group is growing. This will enable your group to compare the prices the market charges with the prices that they will assign to their vegetables and herbs in Activity 3 (page 29).

Session 8 Youth Activities

Activity 1: Change the Nutrient Solution

The plants in your Grow with the Flow unit have been growing in plain water for one week. Now they need a ready supply of nutrients again.

Turn off the pump and remove it from the catchment tank. If your hydroponic unit sits in the catchment tank, lift it out and set it on a table. Then

carefully dump the water from the tank into a sink.

Next, fill the tank halfway with fertilizer solution, as you did in Session 4, Activity 2. Then start up the system with the new solution in the catchment tank.

Continue to water the plants in the pots with the nutrient solution every three days.

Activity 3: Record Growth Data

Using the same method you used in the previous sessions, calculate the average plant size for each plant in the Grow with the Flow unit and then for each plant grown in soil.

Record this data on the growth charts using the color markers or crayons.

Activity 2: Marketing Hydroponically Grown Produce

To begin this activity, break into groups of two. Each pair should think of ways to promote hydroponically grown produce.

Methods that you might try include

- advertising posters with appealing illustrations of the vegetables;
- slogans to convince customers that hydroponically grown vegetables are better; and

- marketing plans specific for the people to whom you would like to sell your hydroponically grown produce (you could include prices you would charge retail customers).

At the end of the session, each pair should present their promotional or marketing concepts to the entire group.



Session 9



The Nutritional Value of Vegetables

Could you survive on a steady diet of lettuce?

How about nothing but beets?

Do vegetarians really eat only vegetables?

The answer to all three questions is *no*.

Vegetables should be considered important parts of a balanced diet, but vegetarians know that they cannot serve as the **only** component of your diet.

Vegetables provide color, texture, and flavor at mealtime. Another important function of vegetables is to provide fiber, or bulk, to your diet. Some vegetables—for example, celery and lettuce—provide relatively little nutrition but lots of fiber.

Vegetables also provide vitamins. Vitamin A is a human nutrient that is supplied by many vegetables with deep yellow or intense green color:

<i>Kale</i>	<i>Turnip greens</i>
<i>Collard greens</i>	<i>Chinese celery</i>
<i>Yams</i>	<i>Asparagus</i>
<i>Spinach</i>	<i>Carrots</i>
<i>Sweet potatoes</i>	<i>Broccoli</i>
<i>Chinese cabbage</i>	<i>Brussels sprouts</i>

Vitamin C is sensitive to heat and air and can easily be destroyed by overcooking. Vitamin C cannot be stored in the body; it must be supplied every day. Although citrus fruits are the most familiar source of vitamin C, many vegetables also supply vitamin C:

<i>Broccoli</i>	<i>Green pepper</i>
<i>Greens</i>	<i>Cabbage</i>
<i>Brussels sprouts</i>	<i>Chinese cabbage</i>
<i>Tomatoes</i>	

Peas and beans, either dried or fresh, are another important group of vegetables. They are good sources of protein and iron, the same nutrients supplied by meat and fish.

As part of your daily balanced diet, you should include

- one to two servings of a fruit or vegetable high in vitamin A,
- one to two servings of a fruit or vegetable rich in vitamin C, and
- two to four servings of other fruits or vegetables, such as beans, peas, apple, potato, or squash.

Preparing for Session 10

Materials You Will Need

- sharp knives
- a salad bowl and serving utensils
- salad dressing
- forks and plates for your group

Preparation

This is the last session. Your group may want to plant new seeds and start the process again or set up the hydroponic growing unit in a different way.

Session 9 Youth Activities

Activity 1: Nutrition Quiz

Based on what you have learned, match the clues with the vegetables listed. After you finish, your teacher or leader will provide the correct answers.

Clues

- _____ A good source of vitamin C, its stems resemble edible trees.
- _____ A favorite of rabbits, its root is a good source of vitamin A.
- _____ Although its stalks are fun to chew, its primary benefit is fiber.
- _____ Favored in Mexican cooking, it's a good source of protein and iron.
- _____ Is it a vegetable or a fruit? In any case, it is the base for many Italian foods. It is also high in vitamin C.
- _____ A stir fry just wouldn't be the same without this vitamin A vegetable.

Vegetables

1. Tomato
2. Carrot
3. Dried beans
4. Chinese cabbage
5. Celery
6. Broccoli

Activity 2: Analyze and Interpret a Graph

By now, you should have five weeks of growth data recorded for both the plants grown in the Grow with the Flow unit and the plants grown in soil. Now it is time to analyze this data.

First, which plants have grown more—the hydroponically grown plants or the potted plants?

At Session 8, by how many centimeters (or number of leaves if that is what you've been measuring) did the average growth of the faster growing plants exceed the average growth of the slower growing plants?

Based on the pattern of growth of the faster growing plants, what would you predict the average growth to be this week?

Activity 3: Harvest and Price the Produce

How much do you think your hydroponically grown produce is worth?

You can find out by harvesting all the vegetables from the Grow with the Flow unit at this time.

- For each lettuce plant, assign a value of \$1.29.
- For each Chinese cabbage or celery plant, assign a value of \$0.99.
- For each herb plant (basil, parsley, sorrel, chives, or scallion), assign a value of \$0.89.

As a group, calculate the total value of the plants that you have grown. Next,

assume that you are able to grow six crops per year. What would be the total annual value of the produce? After you finish your calculations, store each vegetable in a separate plastic bag, and place the bags in a refrigerator for use in the next session.

During the next week, go to a market where vegetables are sold and research the price for each of the vegetables you have grown. Bring this list of prices to use in your report in Session 10. Were the values you assigned to each of your crops realistic?

Session 10

Career Choices in Plant Science

Why do individuals choose careers that involve growing plants?

- They want to help feed the people in their country or in other parts of the world.
- They enjoy trying different methods of growing, to see which ones work best.
- They appreciate the beauty of flowering plants or shrubs and trees, which improve our city environments and home landscapes.
- They just like to watch things grow.

There are many career opportunities in *horticulture*, which is the science and art of growing plants.

Vegetable growers grow their crops in various systems: they can devote huge fields of many acres to a single crop such as sweet corn. Or they can use a smaller plot for growing vegetables to sell at a roadside stand.

When weather conditions don't allow outdoor growing, vegetables can be grown in greenhouses, either in soil or, as you have done, hydroponically!

Floriculturists grow flowering crops, either for cutting or as potted plants. They grow most of their crops in glass or plastic greenhouses, but in the South and during summer months in the North they can also grow field flowers.



Nursery managers grow trees, shrubs, and ground covers. Some trees and shrubs are grown in fields and then are dug when they are ready for sale. Others are grown in containers.



Orchard managers grow tree fruits, such as apples, pears, plums, peaches, and cherries, and small fruits, including raspberries, strawberries, boysenberries, and blackberries.

Other horticulturists are more involved in maintaining plants than in growing them.

Landscape and turfgrass managers maintain trees, shrubs, flower beds, lawns, and golf courses.

Arborists prune, plant, and protect trees.

Interior plantscapers take care of the plants growing in restaurants, malls, banks, and offices.



The positions for which you might qualify depend on your level of training and experience. During summers and afternoons while in high school, you could get a job maintaining greenhouse plants, mowing lawns and caring for flower beds, or planting trees in a nursery.

After graduation from high school, you might be able to start your own small landscape maintenance business, be responsible for running a single greenhouse, or be an assistant to an orchard manager or vegetable grower. All these positions require that you have some prior experience in the field.

Most successful horticulturists first developed an interest in growing plants when they were young. A high percentage of management-level horticulturists completed a two- or four-year college degree before progressing in their professions to become landscape business owners, nursery managers, floriculturists, golf course superintendents, and orchard managers. So it's not too early to be thinking about a career on the green side—in horticulture.

Session 10 Youth Activities

Activity 1: Final Reports

As a group or individually, prepare a ten-minute oral report on your experience with the Grow with the Flow project. Emphasize the following points in your report:

- What you learned about how hydroponics affects plant growth (size, quality, growth rate)
- The nutritional value of each of the crops you grew
- The dollar value of the crops you grew
- Your interest in other gardening projects
- Your interest in horticulture as a career

Activity 2: Prepare, Eat, and Enjoy a Salad

When all the oral reports have been given, it's salad time!

Trim all the vegetables you harvested last week. Cut off the roots of the greens, and remove any outer leaves that have holes or that are discolored or wilted.

Although the greens should be clean, you should still give them a light washing under cold water. Shake them dry or wipe them lightly with paper towels.

Prepare a vegetable salad by tearing the greens into bite-sized pieces. Use a sharp knife to cut the scallions and herbs into small sections or flakes. Mix the vegetables together in a bowl with salad tongs or two large spoons. For dressing, you could use a bottled mix or make your own by mixing one part vinegar with three parts salad oil (olive oil is healthy and tasty).

Enjoy!

Appendix

Construction of a Horizontal Hydroponic Unit

General Information

The horizontal hydroponic unit (fig. 1) is constructed of 1 1/2-inch PVC pipe connectors, 1 1/2-inch PVC fittings (T sections and 90° elbows), 1/2-inch ABS feed line, spaghetti (feed) tubing, and emitters.

The T sections and two 90° elbows are connected with short lengths of PVC pipe to construct a U-shaped unit that lies horizontally on a surface. The openings of each T section (a) are

positioned vertically (upward) to become the grow ports in which plants will be set to grow. Two 90° elbows (b) attached to each end of the U-shaped unit and positioned vertically (downward) connect the unit to a catchment tank. The feed line (c) is fastened to one leg of the U-shaped unit. Spaghetti tubes (d) run from the feed line to the grow ports.

The unit is suspended from a simple plant light stand (e)

using light chain and S hooks and attached to a pump (f), which sits on the covered catchment tank (g). Liquid is pumped from the catchment tank through the feed line and feeder tubes to each plant. Liquid returns through the unit to the tank by gravity.

Before beginning, read all the directions thoroughly to understand fully the construction approach.

Tools You Will Need

- a miter box, to make straight cuts
- a hack saw, with a 24- or 32-teeth-per-inch blade
- a pen or utility knife
- a commercial hole punch, a #20 nail, or an ice pick
- an electric drill with a 3/8-inch bit

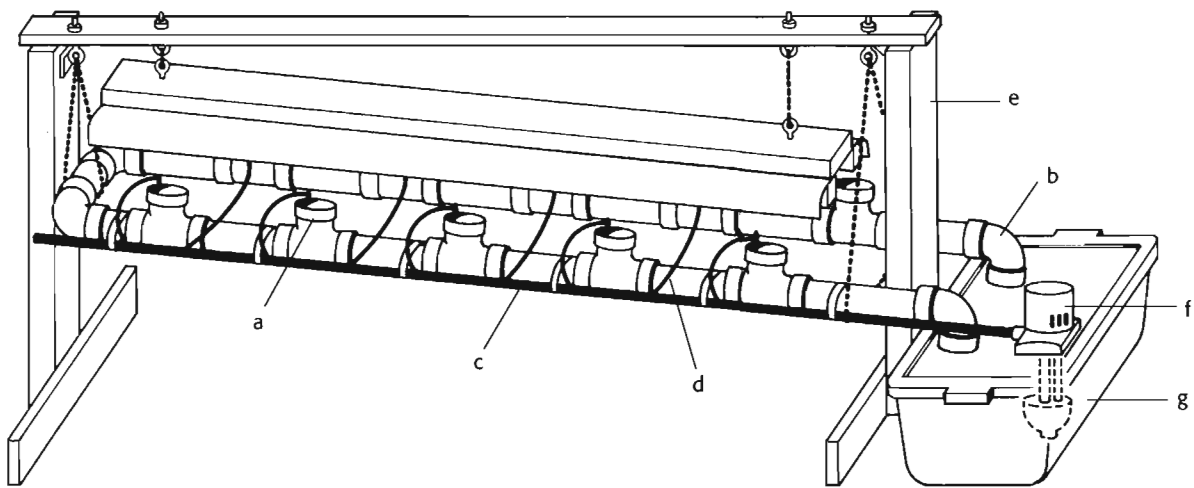

Figure 1. Horizontal hydroponic unit

Materials You Will Need

For U-shaped unit

- two 3-inch or 4-inch C-clamps
- a ruler or a tape measure
- a 75-inch length of 1 1/2-inch PVC pipe, cut to the following dimensions:
 - one 9-inch connector
 - one 3-inch connector
 - one 2 1/2-inch connector
 - ten 6-inch connectors
- the following 1 1/2-inch PVC fittings
 - ten T sections
 - four 90° elbows
- one small can of PVC pipe cleaner
- one small can of PVC solvent-cement

For feed line and pumping system

- 6 feet of 1/2-inch ABS pipe
- fine sandpaper (120 to 150 grit)
- ten barb connectors (small plastic fittings to connect the spaghetti feed tubes to the ABS pipe)
- ten 18-inch lengths of spaghetti tubing

- one 5/8-inch x 1 1/2-inch bolt or dowel (to plug one end of the ABS feed line)
- one tube of general purpose silicone glue and seal
- one mini hose clamp (to fasten bolt or dowel in place)
- one roll of electrical tape
- twenty 1/2-gallon-per-hour emitters (ten for unit assembly and ten for future replacement)
- ten plastic stabilizer pegs or paper clips
- one catchment tank—16 inches long, 11 inches wide, 7 inches deep—with cover (Rubbermaid Rough Tote Keeper, 3 gallon, model no. 2213, or equivalent)
- one pump, rated 200 gallons per hour, preferably nonsubmersible, such as a fish tank pump (Supreme Aquamaster Power Filter Pump, model PLSW, or equivalent)

To attach unit to the plant light stand

- four 18-inch lengths of light chain
- eight 1/2-inch S hooks
- two 3/8-inch x 2-inch threaded eye bolts, each with 2 nuts and 2 flat washers

Assembly

1. Cut the 75-inch length of PVC pipe into the lengths specified in the list of materials, following the same cutting procedures described in the assembly instructions for the standing unit (steps 1 and 2).

2. Referring to figure 2, lay out the elbows, T sections, and PVC pipe connectors on a flat surface.

3. Assemble the unit without cement to make sure all the parts fit correctly and to establish the proper orientation of all the fittings. When inserting a connector into a fitting, the connector should fit inside about one-third to halfway.

Note: Be sure that the openings of the T sections are perfectly upright; these will be the grow ports for the plants. The two elbow fittings that attach the ends of the U-shaped unit to the catchment tank must be oriented downward.

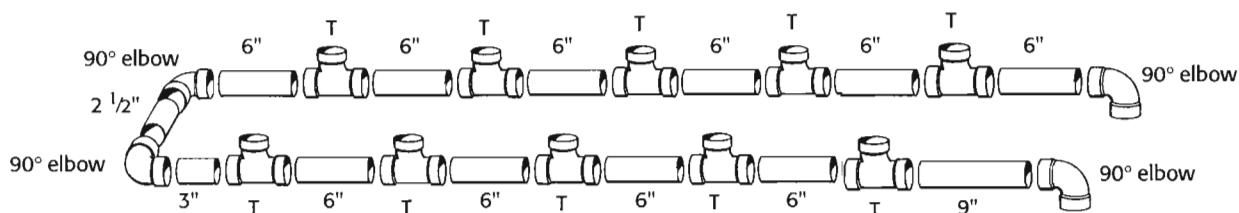

Figure 2. Proper assembly of the U-shaped unit

HOUGHTON

4. When the unit is assembled without cement and all the fittings are properly oriented, draw alignment marks on the pipe connector pieces and their adjoining fittings and number (or letter) each fitting and pipe connector joint. These marks will ensure the proper placement and realignment of all components when the unit is reassembled with PVC solvent-cement.

5. Disassemble the unit, then begin to reassemble it permanently using the PVC pipe cleaner and PVC solvent-cement as follows:

- Work on one joint at a time. You'll need to work quickly, as PVC solvent-cement sets in about 30 seconds.
- Apply PVC pipe cleaner to the outside surface of the pipe connector and the inside surface of the fitting. Allow the surfaces to dry.
- Apply PVC solvent-cement to the outside surface of the pipe connector and the inside surface of the fitting. With the alignment marks on the pipe connector and the fitting oriented 90° apart, insert the connector into the fitting

until it is snug (as in assembling the joints without cement), simultaneously twisting the pipe 90° until the two alignment marks match. Do this quickly, as you have only about 30

seconds before the solvent-cement sets.

6. When the unit has been permanently cemented together, allow the PVC solvent-cement to cure for about 3 hours.

Note: Caution must be exercised when working with PVC pipe cleaner and PVC solvent-cement. Wear eye protection and appropriate clothing to prevent contact with eyes and skin. These chemicals are volatile and noxious and must be used in a *well-ventilated* area. Return the covers/applicators of these substances to their respective containers and seal them after each use to keep fumes to a minimum. Read and observe all manufacturer's warnings and directions for use.

Adding the feed line and feed tubes

1. Place the U-shaped unit on a flat surface in its proper horizontal position. Place the 1/2-inch ABS feed line parallel to one side of the hydroponic unit (fig. 3) so that one end of the feed line is even with the base of the U and the other extends beyond the two open ends of the unit.

2. Mark the feed line at intervals that align with the grow ports in the unit. These locations are where the barb connectors (and then the spaghetti feed tubes) will be inserted. It is not critical to measure the intervals exactly—the flexibility of the spaghetti feed tubes allows for a great deal of tolerance (fig. 4).

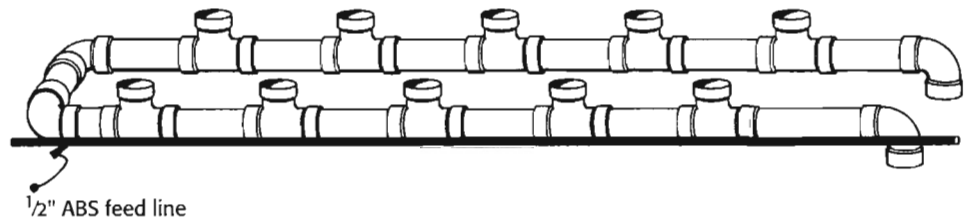

Figure 3. U-shaped unit with feed line

HOUGHTON

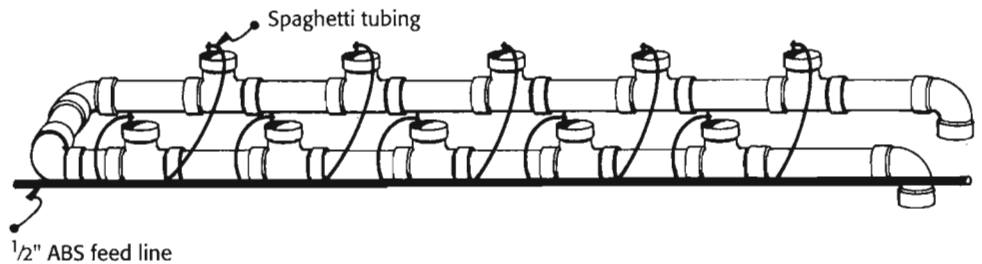

Figure 4. U-shaped unit with feed line and spaghetti feed tubes

HOUGHTON

3. Lay the ABS feed line on a solid, flat surface. Using either a commercial hole punch, a #20 nail, or an ice pick, puncture holes at the locations marked on the pipe. (Do not drill holes. A rough, punctured hole holds the barb connector more firmly in place.) Using fine sandpaper, sand and clean the area around each hole. This will ensure proper bonding and sealing with silicone glue in later steps.

4. Insert a barb connector into each hole and attach an 18-inch length of spaghetti tube to each barb connector.

5. Plug the end of the ABS feed line that is aligned with the base of the U-shaped unit with the $\frac{5}{8}$ -inch bolt or dowel. To ensure a water-tight seal, apply a coating of the silicone glue and seal

around the bolt or dowel, insert it into the end of the pipe, and clamp it in place using the mini hose clamp.

Note: To ensure a proper seal, be sure to use a silicone glue and seal product, not just silicone.

6. Attach the ABS feed line to the outside of the U-shaped unit using electrical tape at several locations.

7. Seal each barb connector using the silicone glue and seal. (To ensure a proper seal, be sure to use a silicone glue and seal product, not just silicone.) Allow the glue and seal to cure for 24 hours.

8. After the glue and seal has cured, trim each spaghetti tube to an appropriate length to reach a grow port. Attach an emitter to the end of each tube.

Note: Do not cut the tubes too short. As the unit is maintained throughout the growing cycle, it will be necessary to remove and replace the emitters. The ends of the tubes will become stretched, making it necessary to trim the tubes.

9. Use a plastic stabilizer peg or a clip fashioned from a paper clip to hold each emitter in place. Secure the peg or clip to the spaghetti tube just above the emitter and insert it into the rock wool plug in the grow port.

10. Attach the completed unit to the plant light stand using the light chain and S-hooks.

a. Drill a $\frac{3}{8}$ -inch hole in each end of the crosspiece of the plant light stand approximately $\frac{1}{2}$ inch toward the center from each upright

and to the inside of the corner brackets, and insert an eye bolt in each hole.

b. Attach an S hook to each end of the four 18-inch lengths of light chain.

c. Wrap one end of each chain around the pipe connectors near the elbow fittings at both ends of the U-shaped unit. Use the S hook to attach the chain end to the chain. Attach the other ends of each chain to the two eye bolts in the plant light stand using the remaining S hooks.

d. Adjust the chain links up or down on the S hooks so the unit pitches slightly downward at its open ends to allow for drainage into the catchment tank. The open ends of the unit should straddle the 2-by-4 upright of the plant light stand.

Preparing the catchment tank

1. Your catchment tank should hold approximately 3 gallons. (A Rubbermaid Rough Tote Keeper works well. It also comes with a cover, which supports the pump and reduces evaporation. If the container available does not have a cover, you can construct one from $\frac{1}{4}$ -inch plywood.)

2. Place the catchment tank at the open ends of the U-shaped unit (where the elbow fittings point vertically downward for drainage) outside the upright of the plant light stand.

3. Position the elbow fittings on top of the catchment tank cover and trace around each fitting. Remove the tank cover and carefully cut along the traced lines using a utility knife, creating two holes for the elbow outlets. Place the tank and cover in place so that the elbow fittings fit through the cover.

4. With the catchment tank in place, align the open end of the ABS feed line so it extends over the tank cover. At the outside edge of the cover aligned with the feed line, trace a 2 $\frac{1}{2}$ -inch hole.

This opening will accommodate the intake of the pump, which will sit on the tank cover. Remove the tank cover and carefully cut along the traced line using a utility knife.

Note: The placement and size of the hole in the catchment tank cover may vary depending on the size and configuration of the pump used. If a submersible pump is used, the hole in the cover will need to be just large enough for the ABS feed line to connect to the pump outlet. A 3-gallon

catchment tank, however, will accommodate only a very small submersible pump.

5. Replace the tank cover and insert the pump intake through the cover. Trim the end of the ABS feed line so it fits into the pump outlet. Connect the pump to the feed line. If a straight connection is not possible, use a short length of flexible tubing and two mini clamps to complete the connection.

Construction of a Simple Plant Light Stand

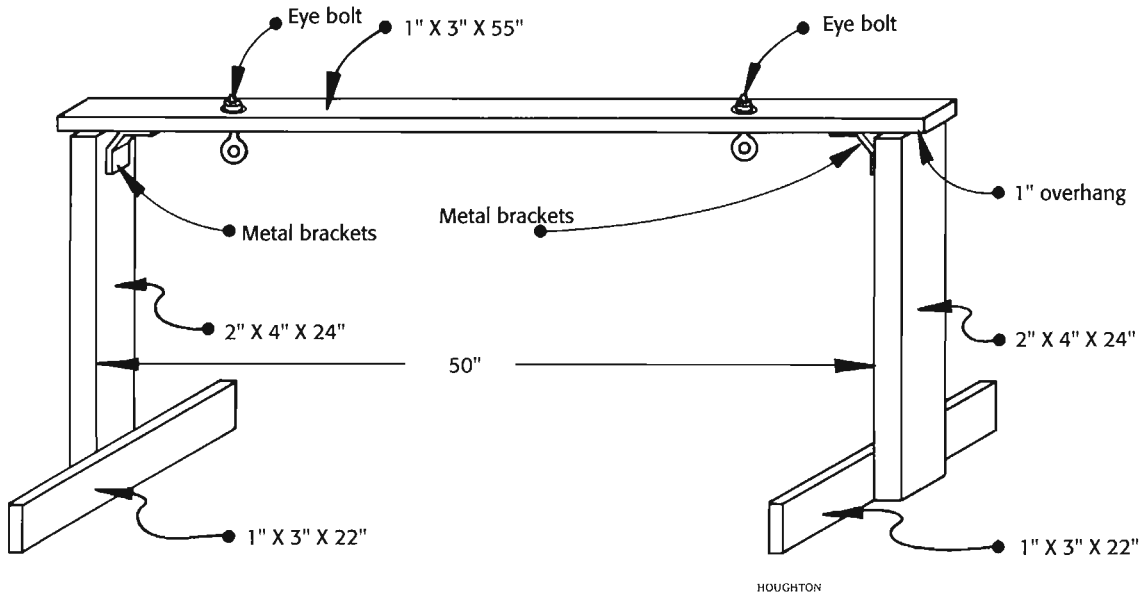

Figure 5. Simple plant light stand

Tools You Will Need

- a crosscut saw
- a hammer
- a small carpenter's square
- an electric drill with a $\frac{3}{8}$ -inch bit
- a screw driver

Materials You Will Need

- two 24-inch lengths of 2-by-4 lumber
- two 22-inch lengths of 1-by-3 lumber
- one 55-inch length of 1-by-3 lumber
- sandpaper
- fourteen #6 rosin-coated nails
- two metal corner brackets with screws
- two $\frac{3}{8}$ -inch x 2-inch threaded eye bolts, each with 2 nuts and 2 flat washers
- paint or varnish
- one 48-inch, two-tube shop light
- two 12-inch lengths of light chain, each with two S hooks (may come with shop light)
- an automatic timer (optional)

Assembly

Note: The dimensions of the plant stand (fig. 5) can be adjusted to meet individual needs. The height can be adjusted to suit the type of plants to be grown and the space available. The length also can be adjusted depending on the length of the shop light available.

1. Cut the lumber into the lengths specified in the list of materials.
2. Sand the lumber. The degree of sanding needed depends on how you intend to use the light stand. A stand that will be used in public displays should be finished to a greater degree than one that will be used in a laboratory. (For a professional finish, use wood screws instead of nails, countersink them, and cover them with wood filler.)

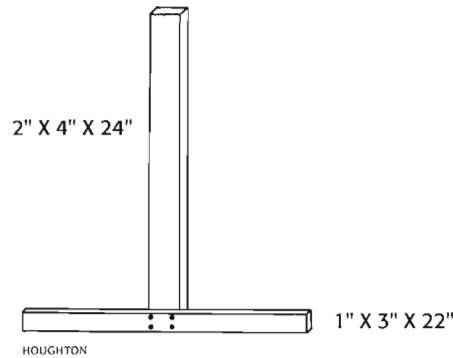

Figure 6. Plant stand upright

3. Nail each 22-inch length of 1-by-3 lumber (base) to a 24-inch length of 2-by-4 lumber (upright) as shown in figure 6. Use four nails at each end.

4. Nail the 55-inch length of 1-by-3 lumber to the top of each upright, allowing a 1-inch overhang at each end. Use three nails at each end. This will be the crosspiece of the stand, which will support the shop light.

5. To strengthen the stand, fasten the corner brackets to the inside of the joints made by the uprights and the crosspiece. Offset each corner bracket to allow for the eye bolts that will support the hydroponics unit. On one end offset the bracket toward one side of the crosspiece, and on the

other end offset the bracket toward the opposite side of the crosspiece.

6. Drill two $\frac{3}{8}$ -inch holes in the crosspiece. These are for the eye bolts that will be used to hang the light. Position the holes so they correspond to the location of the hanger holes and brackets on the shop light being used and are centered on the crosspiece. Insert the eye bolts.

7. Apply paint or varnish to finish the stand and allow to dry.

8. Hang the shop light from the eye bolts with the 12-inch chains and S hooks. For optimum plant growth, use one warm white and one cool white fluorescent tube in the light fixture.

9. To provide uniform light each day, use an automatic timer. Set the timer according to the manufacturer's instructions for the desired period of light.

10. Attach the horizontal hydroponic unit to the plant light stand as described in the assembly instructions for the unit (step 10).

Construction of a Standing Hydroponic Unit

General Information

The standing hydroponic unit (fig. 7) is constructed of 1 1/2-inch PVC pipe connectors, various 1 1/2-inch PVC fittings, 1/2-inch ABS feed line, spaghetti (feed) tubing, and emitters. The PVC fittings (a), positioned on three leg sections (b), provide the holes for the plants (c) and the feeder tubes (d). The unit stands in a catchment tank (e),

covered to reduce evaporation. The legs perforate the cover. The liquid is pumped through the feed line (f) and the feeder tubes to each plant and returns by gravity directly to the catchment tank through the legs. Holes drilled at the bottom of the legs allow drainage into the tank.

The unit is constructed in seven sections, which include three leg assemblies, two upper leg supports, one upper brace, and one lower brace. Each of the seven sections is assembled permanently with PVC solvent-cement. When located at a selected site, the sections are dry-assembled to make the complete unit. As liquid only flows vertically down the legs, the dry-assembled horizontal joints pose no leakage concerns.

The PVC fittings (T, cross T, single Y, and double Y sections and elbows) (fig. 8), which are designed for one-way flow, have top-inlet and

bottom-outlet ends. They can only be positioned in one direction for proper fit and function. Exercise care, noting proper orientation, when assembling.

Note the direction of the single and double Y fittings. The fitting is not on center, but rather is located 1/4 inch closer to the top-inlet end (fig. 8). If uncertain, a look inside the fittings will readily reveal the flow direction.

Before beginning, read all the directions thoroughly to understand fully the construction approach.

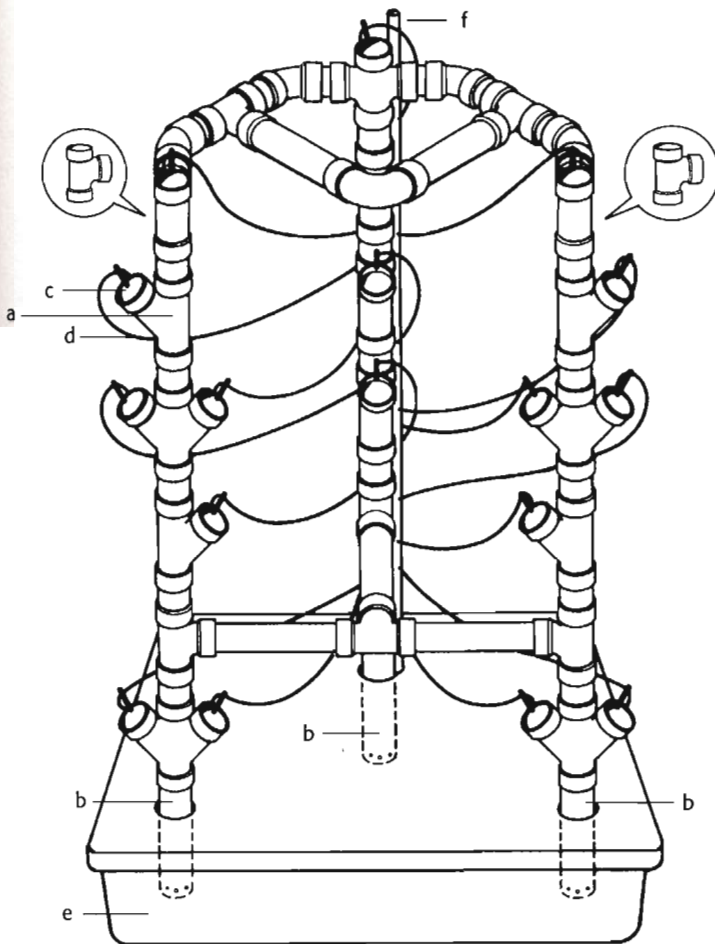

HOUGHTON

Figure 7. Standing hydroponic unit

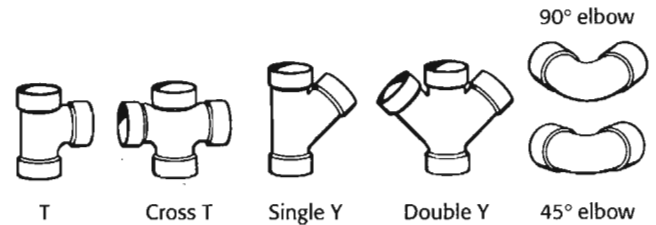

Figure 8. PVC fittings

HOUGHTON

Tools You Will Need

- a miter box, to make straight cuts
- a hack saw, with a 24- or 32-teeth-per-inch blade
- a pen knife
- an electric drill with a 1/4-inch bit

Materials You Will Need

- a ruler or a tape measure
- two 3-inch or 4-inch C-clamps
- a 10-foot length of 1 1/2-inch PVC pipe, cut to the following dimensions:
 - eight 1 3/4-inch connectors
 - fifteen 2 1/2-inch connectors
 - three 6 3/4-inch lengths
 - three 7-inch lengths
 - two 7 1/4-inch lengths
- the following 1 1/2-inch PVC fittings
 - eight T sections
 - six single Y sections
 - six double Y sections
 - one cross T section
 - four 45° elbows
 - one 90° elbow
- one small can of PVC pipe cleaner
- one small can of PVC solvent-cement
- one sheet of poster board
- a pencil
- scissors
- one catchment tank—30 1/2 inches long, 20 inches wide, 6 inches deep—with cover (Rubbermaid storage box, 43 quart, model no. 47-4L, or equivalent)
- one submersible pump, rated 120 gallons per hour (Little Giant model P-AAA or equivalent)
- 6 feet of 1/2-inch ABS pipe
- 19 barb connectors
- one roll (75 feet) of spaghetti (feed) tubing
- one tube of silicone glue and seal
- one roll of electrical tape
- 19 emitters
- 19 plastic stabilizer pegs or clips

Assembly

1. Fasten the miter box to the work surface with a C-clamp. Using a second C-clamp, secure the PVC pipe in the miter box to ensure a square cut. Using the hack saw and the 90° cutting guides on the miter box, cut all connectors and lengths to the dimensions specified.

Other cutting methods may be employed. Miter boxes with attached tubular saws that have replaceable blades can be used if a fine-tooth blade (like that of a hack saw) can be obtained. Power saws, such as a radial arm saw, should be used **only** by adults knowledgeable in tool operation and blade selection.

2. Once cutting is complete, carefully use a pen knife to remove burrs on the inside and outside edges of the cut pipe.

3. Assemble the unit without cement to make sure all the components fit correctly and to establish the proper orientation of all the fittings. When inserting a connector into a fitting, the connector should fit inside about one-third to halfway. Assemble each section individually and then combine all seven sections (two upper leg supports, one

upper brace, one lower brace, one center leg assembly, and two outer leg assemblies) to complete the entire unit. Work on a flat, level surface.

As each component is assembled, draw alignment marks on the connectors and their adjoining fittings and number (or letter) each fitting and joint. These marks will ensure the proper placement and realignment of all components when the unit is reassembled with PVC solvent-cement. Note that the alignment marks are unique to each joint; therefore, the same connector ends and fitting ends will be rejoined during final assembly.

Assemble the unit without cement in the following way:

a. Using one T section, two 45° elbows, and four 1 3/4-inch connectors, assemble one upper leg support (as shown in figure 9). You don't need to consider the orientation of the T section at this time. Be sure that the elbows are aligned accurately in the same plane. Repeat the procedure to assemble the second upper leg support.

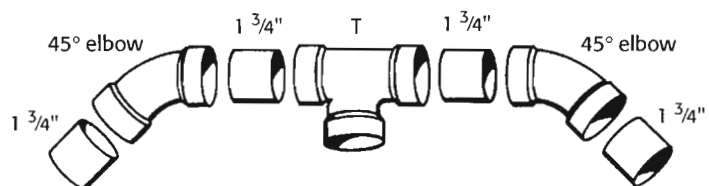

Figure 9. Upper leg support

HOUGHTON

b. Using two 6 3/4-inch connectors and one 90° elbow, assemble the upper brace (as shown in figure 10).

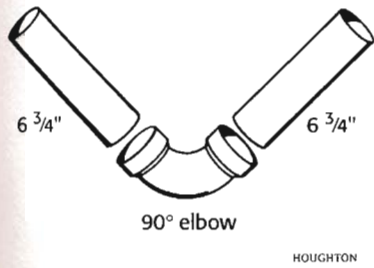

Figure 10. Upper brace

c. Using one T section, one 6 3/4-inch connector and two 7 1/4-inch connectors, assemble the lower brace (as shown in figure 11). Join one 7 1/4-inch connector to the top-inlet end of the T section. Join the 6 3/4-inch connector to the bottom-outlet side of the T section. Join the remaining 7 1/4-inch connector to the middle-center connection of the T section. (Using connectors of different lengths compensates for the off-center middle connection of the T section and centers the middle connection in the completed brace assembly.)

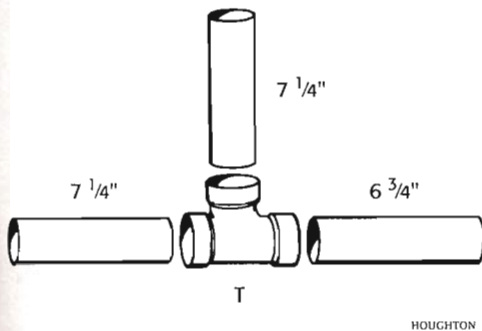

Figure 11. Lower brace

d. Using one T section, two single Y sections, two double Y sections, five 2 1/2-inch connectors, and one 7-inch PVC pipe connector, assemble one leg assembly (as shown in figure 12). Top fittings will be added later. Assemble all the fittings on a flat work surface. Make sure the top-inlet ends of all the fittings face toward the top. As you work, place a board lengthwise across the work surface to ensure that the assembled leg is straight. Begin by joining the double Y section to the 7-inch connector, with the opening of the double Y section facing right and left. Finally, connect the remaining single Y section to the top of the double Y section, with the opening facing left.

Repeat this procedure to assemble the other two leg assemblies.

e. Attach a cross T section to the top of one leg assembly, orienting its opening 90° to the openings of the other sections (as shown in figure 13). (Note that there are markings at the ends of the sections spaced 45° apart, which aid in orientation). This completes the center leg assembly.

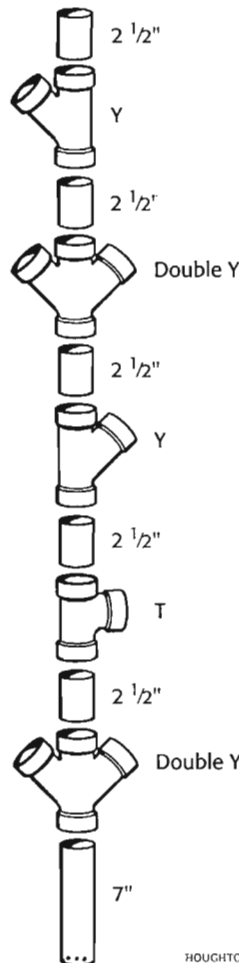

Figure 12. Leg assembly

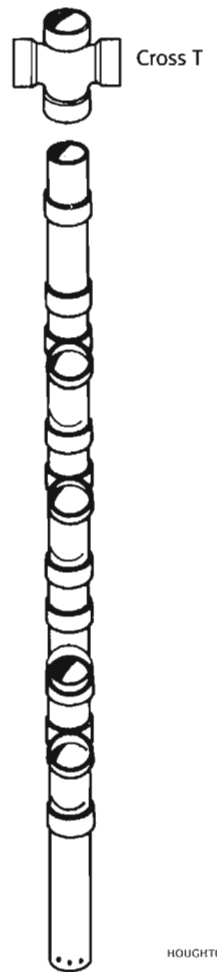

Figure 13. Center leg assembly

f. To complete the outer leg assemblies, attach T sections to the top of each, orienting their openings 90° to the openings of the other sections (as shown in figure 14). Note that for one leg assembly the opening of the lower T section must face to the right, and the opening of the lower T section of the other leg must face to the left. Check by holding the two leg assemblies vertically: make sure the openings of the top T sections face the same way while the openings of the lower T sections face one another.

g. Assemble all seven sections together to create the completed unit (as shown in figure 15). First attach the three leg assemblies to the lower brace; the center leg assembly attaches to the pipe from the middle-center connection of the T section. Attach the upper leg supports to the center leg assembly and both outer leg assemblies; the top-inlet ends of the T sections should face toward the cross T section on the center leg assembly. Connect the upper leg supports to the top-inlet ends of the T sections on the upper leg supports.

4. Be sure that you have drawn alignment marks on all the connector pieces and their adjoining fittings and have numbered (or lettered) each fitting and joint. To prepare the unit for final assembly, break down the unit into the seven sections (two upper leg supports, one upper brace, one lower brace, one center leg assembly, and two outer leg assemblies).

5. Drill drainage holes toward the bottom of the 7-inch connectors on the leg assemblies: first remove the pipes from the three leg assemblies; then drill eight 1/4-inch holes set 45° (about

1/2 inch) apart, 3/4 inch from the bottom end. Temporarily rejoin the pipes to the leg assemblies to keep the sections complete.

6. Permanently assemble all seven sections using PVC pipe cleaner and PVC solvent-cement. Assemble one section at a time, following the same procedures you used to assemble the unit without glue (steps 3a through 3f).

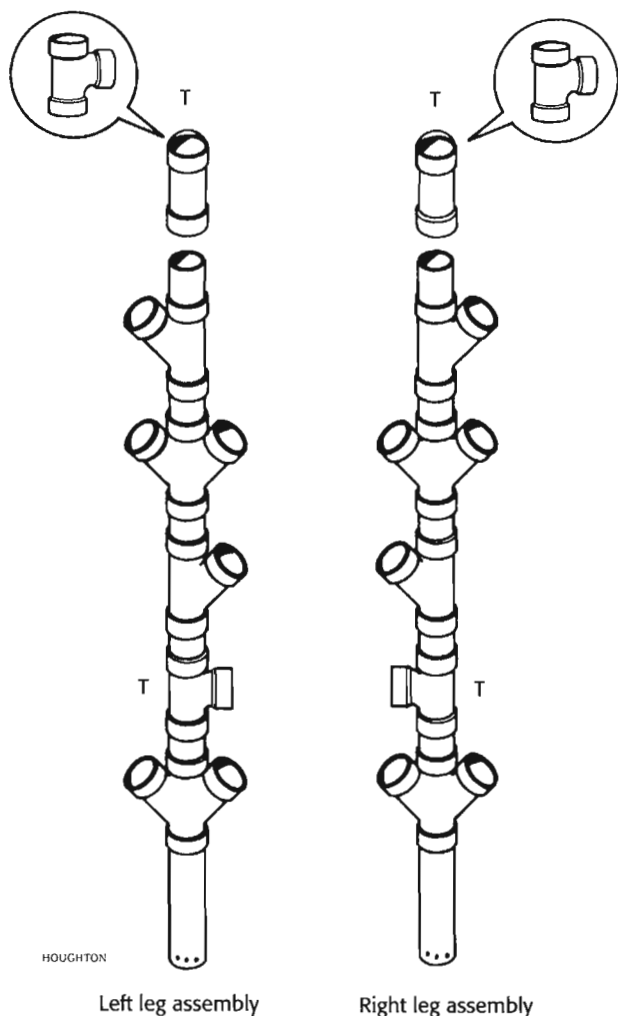

Figure 14. Outer leg assemblies

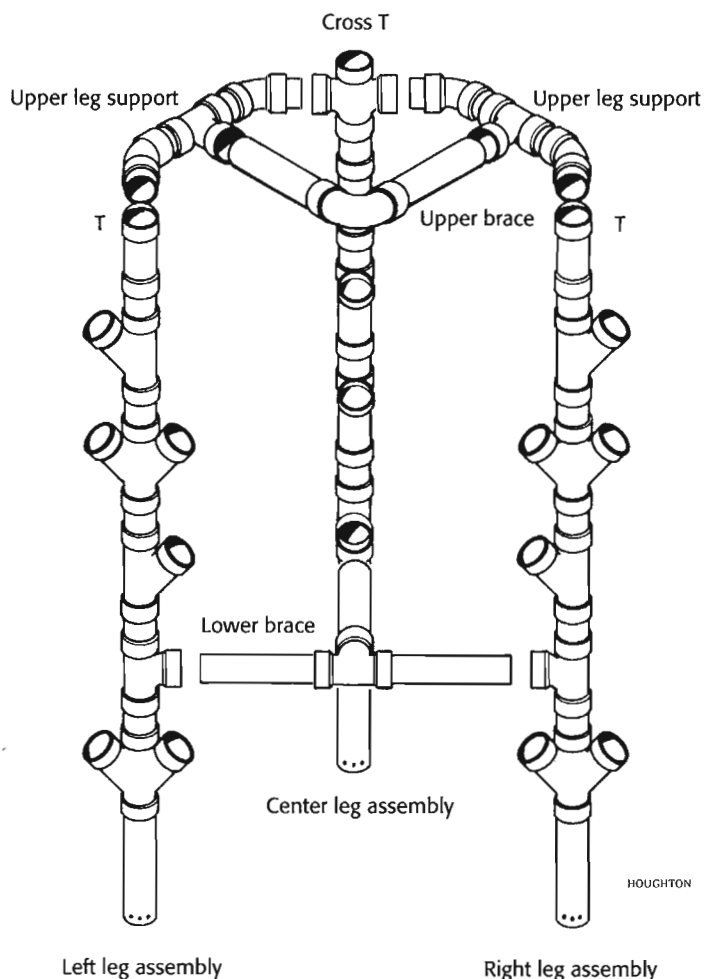

Figure 15. Proper assembly of the standing hydroponic unit

Note: Caution must be exercised when working with PVC pipe cleaner and PVC solvent-cement. Wear eye protection and appropriate clothing to prevent contact with eyes and skin. These chemicals are volatile and noxious and must be used in a *well-ventilated* area. Return the covers/applicators of these substances to their respective containers and seal them after each use to keep fumes to a minimum. Read and observe all manufacturer's warnings and directions for use.

Assemble the unit with cement in the following way:

- a. Work on one joint at a time. You'll need to work quickly, as PVC solvent-cement sets in about 30 seconds.
- b. Apply PVC pipe cleaner to the outside surface of the pipe connector and the inside surface of the fitting. Allow the surfaces to dry.
- c. Apply PVC solvent-cement to the outside surface of the pipe connector and the inside surface of the fitting. With the alignment marks on the pipe connector and the fitting oriented 90° apart, insert the connector into the fitting until it is snug (as in assembling the joints without glue), simultaneously twisting the pipe 90° until the two alignment marks match. Do this quickly as you have only about 30 seconds before the solvent-cement sets. A continuous bead of solvent-cement showing all around the seam of the joint indicates a correctly cemented joint.

d. Read and follow carefully the manufacturer's directions for further information on the correct use of PVC pipe cleaner and PVC solvent-cement.

7. Carefully assemble the seven sections to complete the unit. Note that it takes about 12 hours for PVC solvent-cement to cure fully.

8. Center the sheet of poster board under the three legs of the assembled unit and trace their outlines with a pencil. Using scissors, cut out all three circles. With the circles in the center, cut the poster board to a dimension slightly smaller than that of the inside of the catchment tank cover. Center the poster board on the cover and trace the three circles on the cover. Cut out the circles on the cover using a pen knife. The legs of the unit can now be set into the covered tank, passing through the three holes.

The unit is now ready for installation of the pump, feeder tubes, and other accessories. Adapt the procedure described for the horizontal unit to add the feed line and feed tubes to the standing unit. The feed line is attached to the center leg assembly.

Charles Mazza is urban horticulture program leader, Cornell Cooperative Extension of New York City. Philson A. Warner is Bronx Education Center leader, Cornell Cooperative Extension of New York City. Donald A. Rakow is an associate professor of landscape horticulture, Department of Floriculture and Ornamental Horticulture, College of Agriculture and Life Sciences, Cornell University.

The authors express their gratitude to Carolyn Klass, who helped write "Session 6: When Pests Attack Plants," and David Hillman, Robert McBride, Wayne Torgenson, who helped write the instructions for building two hydroponics units, which are in the Appendix.

Illustrations by Elsie Dentes and Jim Houghton

 This publication was developed to promote 4-H programs in New York State.



Cornell Cooperative Extension
Helping You Put Knowledge to Work

This publication is issued to further Cooperative Extension work mandated by acts of Congress of May 8 and June 30, 1914. It was produced with the cooperation of the U.S. Department of Agriculture and Cornell Cooperative Extension, College of Agriculture and Life Sciences, College of Human Ecology, and College of Veterinary Medicine, at Cornell University. Cornell Cooperative Extension provides equal program and employment opportunities.

Produced by Media Services at Cornell University

Copyright 1993



Printed on recycled paper

141M7 352/625 10/93 4M ML E20397G