

Performance Evaluation of Commonly Used Oil Ram Press Machines

J. Uziak and I. A. Loukanov

Department of Mechanical Engineering, University of Botswana, P/Bag UB0061, Gaborone, Botswana.

uziak@mopipi.ub.bw , loukanov@mopipi.ub.bw

ABSTRACT

The ram-press technology for oil expression has received a lot of attention in many African countries during the last two decades. The technology is based on manually operated mechanical presses, which employ a slider-crank mechanism in two different configurations. The original machine was invented by Karl Bielenberg in 1985 and since then continuous design improvements have been made to improve their performance and ease of operation. This paper deals with the performance of some commonly used ram press machines such as BP-35, BP-30 and FI-32, in order to establish their suitability for small rural oil expression technology. The available oil-seed processing techniques were discussed, including their suitability for locally grown sunflower varieties, and the characteristics of the ram press machines. The machines were tested by using three varieties of sunflower seeds, namely PNR 7225, PNR 7369, and Peredovik. The machines were compared by their outputs obtained when conducting a high production and high expression tests. Based on the above analysis the Camartec design (BP-30) was found to have the best performance. The machine had the highest efficiency and also the highest expression rate in comparison to CAPU design (BP-35) and RAM design (FI-32) machines. The FI-32 machine was found to be ineffective, having in the high expression test an expression rate below 20% irrespective of the type of seeds used. In terms of the speed of oil production the CAPU (BP-35) design performed better than the other machines. However in the high production test its performance was similar to that of Camartec machine.

Keywords: ram press machines, oil expression, slider-crank mechanism

1. INTRODUCTION

The ram press technology for oil expression has received a lot of attention in the last decade. The technology is based on manually operated mechanical presses. The original machine was designed by Karl Bielenberg in 1985 (ATI, 1985). However, there are other designs either based on the original Bielenberg ram press or using different type of mechanisms, such as that of RAM 32 oil expression machine. Oil projects that are based on these relatively simple machines have been started in many sub-Saharan African countries such as Tanzania, Kenya, Uganda, Mozambique, Senegal, Zambia, Benin, Zimbabwe and Mali. Although, this technology was originally developed for the expression of oil from sunflower seed, oilseeds such as Jatropha, sesame mustard and rapeseed have been tested on this machine.

The technology also may be seen as a potential generator of increasing the rural employment and income. To achieve these advantages ram press technology has to be made sustainable. In this respect further work is required, which could include studies on the commercial aspects of ram

press technology, the profitability of entrepreneurship, the utilization of sunflower cake and the introduction of new varieties of sunflower. There is an urgent need for mechanical analysis of the existing ram presses in order to make recommendations as to how the machine itself can be improved.

The paper presents the comparison of the performance of three ram presses machines in terms of their efficiency and extraction rate. The aim of the paper is to present some aspects of oil expression technology in order to create an interest and awareness.

2. OIL-SEED PROCESSING TECHNOLOGIES

The five common methods that are used to extract oil from oil-bearing seeds are listed in Table 1. All these technologies have been applied in Eastern and Southern Africa for seeds including cottonseed, soybean, sunflower and groundnuts (Nazare and Nalumansi, 1996; Akinoso et al., 2006; Asoegwu and Asoegwu, 2007; Olayanju et al., 2006).

Table 1. Oil-Seed Processing Technologies

Technology	Description	Capacity
Solvent Method	Industrial technology; oil-seeds rolled to reduce them to flakes, which are dissolved in a solvent that extracts the oil.	120 tonnes/day
Intermediate (screw expellers) technology	Power-driven technology, oil-seeds continuously fed, pre-heated, crashed and pressed to expel oil as it passes through the machine.	90 kg/h
Oil-plate method	Plunger/cylinder presses, either screw-operated or hydraulically operated	15 kg/batch
Indigenous methods	Traditional domestic method; pounding, boiling and skimming.	Few kg per day
Lever-operated Ram Presses	Manually operated mechanical press, seeds are fed continuously, and oil separates from cake	55kg/shift

Out of the five methods, the ram press technology is the most adaptable to small-scale rural activity. The ram press technology is based on a manually operated machine but allows for continuous feed of the seeds with no need for stopping the pressing in order to feed the seeds. It is less efficient than the industrial-based methods (solvent extraction and using screw expellers) that require special and expensive machinery electrically powered and strict hygienic conditions that are cannot be easily obtained at the small-scale rural level. Indigenous methods on the other hand are not efficient; some of them (like hot water extraction) are very laborious and time consuming.

The ram press technology requires that the seeds be preprocessed and the expressed oil be refined. Seeds to be pressed into oil need to be pre-processed to ensure maximum expression rates and minimum wear to the pressing equipment. Possibilities exist for decorticating of sunflower seed prior to pressing. However, the simplest and most usual form of pre-processing

taking place is preheating the seed in the sun prior to pressing. Oil yield from preheated seed is higher by 25% than from unheated seed. Seeds can be heated by solar radiation, by fuel burning stove or over an open fire. Sun heating involves spreading the seeds on the plastic sheet in the sun up to a layer of 3 to 4 seeds for a period of at least 15 to 20 minutes before starting to press, while stove or fire heating involves heating seeds in an open metal container.

The expressed oil is purified after expressing by one of three methods: filtering (Khaki paper or bucket filter), boiling or settling methods. The Khaki paper filter method, although slow, ensures oil of the cleanest form (Nazare and Nalumansi, 1996).

Although the ram press technology requires two additional processes for the preparation of the seeds and for the filtration, it still remains the most suitable technology for rural operation.

3. CHARACTERISTIC OF RAM PRESS TECHNOLOGY

The ram press is a manually operated mechanical (Fig. 1) press capable of pressing a range of oil-seeds including sunflower, sesame and groundnuts, as well as seeds from pumpkin, rape, watermelon, mustard, and Jatropha Curcas (Bielenberg, 1996; Eliah, 1997; Mugeto, 1990; Uziak *et al.*, 2002]. Coconuts also can be processed using a ram press. The ram press can be operated continuously without the need to remove cake. The capacity of the press is 14 litres of oil for an eight-hour shift, which approximately amounts to pressing a 55-kg bag of seeds, although the capacity would depend on the type oilseed and its temperature at the time of pressing. Operation of the press is very simple and therefore an operator can be trained to use the equipment in about one hour. Maintenance is limited to simple routine cleaning and general checks.



Figure 1. RAM-32 oil expression machine

The original ram press for oil expression was invented by Karl Bielenberg in 1985. There are now several models of ram presses, some are just improvements of the original Bielenberg press whereas others are based on different mechanisms like RAM-32 shown in Fig. 1.

Several features of ram press technology are particularly appropriate for use in rural areas. Its simplicity, low capital cost and low requirements for skilled operation and maintenance are all

significant in the rural environment. Large throughputs are not required, and small local enterprises have an advantage over large plants, for which the cost of transporting the edible oil to rural districts is high. The increased availability of locally extracted oil to rural families encourages its consumption, leading to improved human nutrition, and the community also benefits from the creation of local employment.

The attractions of ram press technology for rural areas may be summarized as follows:

- Simplicity,
- Low repair and maintenance requirements,
- Low investment and operating expenses, and
- Minimal operation skill requirements.

4. SUITABILITY OF SUNFLOWER SEEDS FOR RURAL OIL PRODUCTION

Sunflower is a major oil-seed crop in Eastern and Southern Africa. It is a crop suitable for rural small-scale oil expressing because of high oil-content (40-45% in improved varieties) and because it has agronomic advantages, such as drought tolerance, short growing season and its ease of management.

Two types of sunflower exist: the open-pollinated and hybrid varieties. The hybrid varieties are generally superior for oil expression, having higher oil contents and softer seed coats. Varieties commonly used in the Southern Africa region are shown in Table 2, together with some important characteristics (Nazare and Nalumansi, 1996).

Table 2. Common sunflower seed varieties.

Variety	Country	Days to Maturity (days)	Oil Content (%)
Masasa (hybrid)	Zimbabwe	83-100	45
Peredovik (open pollinated)	Regional	115-125	39
Record (open pollinated)	Tanzania/Zambia/RSA	90-120	40-42
New Sunfolia	Uganda	110	40-45
Russion 4 (open pollinated)	Botswana	140-150	35

Table 3 presents the characteristics of 5 typical varieties of sunflower used for testing the three most commonly used ram press machines, mainly Camartec (BP-30), CAPU (BP-35), and RAM-32, the latter one is known as JH-32, or FI-32 machine.

Table 3. Sunflower seed.

Variety	Moisture content (%)	Oil content (%)	Crude fibre (%)	Crude protein (%)
PNR 7225 (hybrid)	6	42	16	21
PNR 7369 (hybrid)	7	45	17	19
Peredovik (open pollinated)	5	45	13	23
Russian 4 (open pollinated)	7 - 10	35	18	24
Record (open pollinated)	8	41	16	20

Fats and oils are highly concentrated sources of energy. They supply 9 kcal/g which is twice that provided by proteins and carbohydrates. Fats also act as carriers of fat-soluble vitamins. Field

surveys in the areas where ram press extracted sunflower oil is being used indicate that the product is readily accepted by consumers. Ram-pressed sunflower seed oil is mainly used for frying food. It improves the flavour of food and is cholesterol free. Oil produced using a ram press also can be used to produce jelly, soap, body and hair cream.

The by-product of oil expression using ram press technology is the seed cake (seed residue). It is an important feature of the ram press technology as the cake is rich in protein, fat and vitamins and it is an excellent feed for livestock. Commercial high protein feed stuffs is very rare in the rural areas but, when available they are usually expensive. The remaining residue of the sunflower seed, after it has been pressed, therefore, could become a valuable source of affordable protein. The proximate composition (including the mineral content) of hybrid sunflower seed (suitable for oil expression) before pressing and after pressing, showing the content of the sunflower cake is presented in Table 4 (Nazare et al., 1994). The data shown is the average of 5 crops, namely hybrids PN7225, PNR7369 and G101, and open-pollinated Peredovik and Record. The data for the cake represents the content after pressing out 13.5 litres of oil from the 55-kg bag of sunflower seed.

Table 4. Content of hybrid sunflower seed and cake (moisture free basis).

Content	Moisture (%)	Crude Protein (%)	Fat (%)	Crude Fibre (%)	P (%)	Ca (%)	Ash (%)	Carbohydrate (calc) (%)
Seed	6.3	22.4	46.3	16.7	0.9	0.3	3.6	11.0
Cake	-	29.6	29.0	22.1	1.2	0.4	4.7	14.53

Apart from sunflower seeds other oil bearing seeds (especially groundnuts and sesame) have been also used for oil expression however on a much smaller scale. Table 5 presents the percentage expression rate in litres of oil per kilogram of seed for various oil seeds (Henriksson, 1993). The expression rate was obtained by using an IAE (Institute of Agricultural Engineering, Harare, Zimbabwe) version of ram press.

Table 5. Expression rate of oil.

	Treatment	Expression Rate
Sesame	Sun	31%
Rape	Sun	31%
Groundnuts	Scorched	30%
Sunflower	Sun	28%
Jatropha Curcas	Sun	27%
Mustard	Sun	19%
Pumpkin	Scorched	18%
Linseed	Sun	15%
Watermelon	Scorched	4%

5. THE RAM PRESS DESIGN

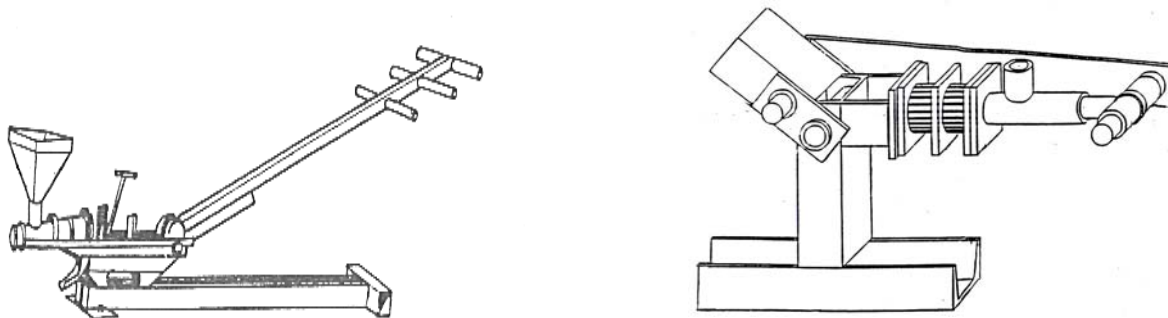

Figure 2. Typical Ram press 3D-schematic. Figure 3. Parts of the classical ram press design.

The geometry of the original ram press design is schematically shown in Fig. 4. As it can be seen from the figure, it is a typical offset slider-crank mechanism in its usual configuration.

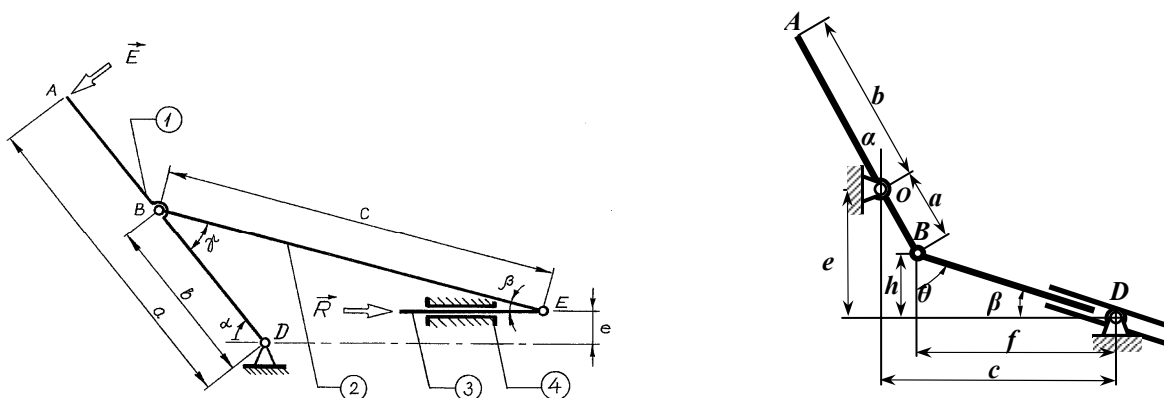

Figure 4. Free body diagram of an offset ram press. Figure 5. Kinematics' diagram of RAM-32.

The ram press operates by applying pressure to seeds inside a cylinder and cage by means of a piston and a system of levers. Under the pressure built in the cage the seeds release oil, which flows out through the slots available in the cage. The remaining cake is forced out at the other end of the cage past a conical restrictor. The operation can be summarized as follows.

- When the handle is raised, seeds drop down from a hopper through the inlet port into the cylinder.
- Then the piston is moved forward when the handle is lowered, pushing the seeds into the cage under increasing pressure. When the pressure has risen enough, oil is squeezed out of the seeds and drips from the cage through the cage slots.
- Cake is extruded from the opposite end of the cage provided that sufficient pressure has been built up in the cage. The latter is controlled by means of the adjustable restrictor.

The other non-typical design of a ram press machine recently developed (RAM-32) is based on an inverted slider-crank mechanism and its kinematics' diagram is presented in Fig. 5. This machine also is known as FI-32 or JH-32.

6. COMPARISON BETWEEN RAM PRESSES

Since 1985 the original design of the ram press has undergone several modifications to improve its efficiency and ease of operation. The original, large, two-man machine has evolved into a smaller, less expensive model that can be operated by one person. There are currently several models of ram presses commonly in use in the Eastern and Southern Africa regions, and basic configuration information for these is shown in Table 6 (Henriksson, 1992; Nazare *et al.*, 1994).

Table 6. Ram press specifications.

Ram Press	Mass (kg)	Piston Diameter (mm)	Handle Length (m)	No. of operators	Bushing	Cage shape
Bielenberg	+100	50	2.00	2	Bronze	Tapered
CAPU (BP-35)	+60	40	1.70	1	Bronze	Tapered
Camartec (BP-30)	+40	30	1.00	1	None	Straight
ApproTEC	+90	32	1.67	1	Bronze	Tapered
IAE	+48	32	1.30	1	Boiler-pipe	Straight
RAM-32 (JH32), (FI-32)	+26	32	0.98	1	None	Tapered

The performance of three different ram presses for sunflower oil expression was compared by performing two typical performance tests; namely a high production test and a high expression test. The aim of the *high production* test was to process maximum amount of oil seeds. It should also mean that the maximum possible amount of oil was expressed. The amount of seeds processed was measured by the time taken to process a typical 55 kg bag of seeds (hours per 55 kg) whereas the amount of oil expressed was measured in litres per hour (litres/hour). During the *high expression* test the operator let the handle rest at the lowest position for about 2 seconds to allow the oil to flow from the cake. The cone also was set to achieve a slightly higher pressure as compared to the high production test. In this test the emphasis was put on the amount of oil expressed from a given amount of seeds. It has been measured by the *expression rate*, or more appropriately by the *efficiency*. Each expression rate test was performed on approximately 3 kg of seeds, which were weighed before being pressed. The volume of expressed oil and the time it took to express the oil were also measured. The expression rate was taken as litres of oil per kilogram of seeds, and then converted to a percentage figure (kg per kg) using the density of oil at 0.93 kg/litre. The efficiency was expressed as the ratio of the amount of oil expressed (in kg) to the theoretical amount of oil (in kg) in the seeds based on the oil content.

Three different varieties of sunflower seeds were used in the tests, namely; PNR7225-*No.1*, and PNR7369-*No.2* being hybrid seeds, and Peredovik-*No.3* – being an open-pollinated seed. The following versions of the ram press were used to express oil from these sunflower seeds: Camartec, CAPU-35, and FI-32. The oil contents of these varieties are shown in Table 3, and the results obtained, based on several runs, are listed in Tables 7 and 8.

Table 7. High production test.

Press type/ Variety	Hours per 55 kg			Litres/hour			Litres per55 kg			Expression Rate (%)			Efficiency (%)		
	1	2	3	1	2	3	1	2	3	1	2	3	1	2	3
Camartec	6.8	4.7	5.6	1.8	2.6	1.7	12.3	12.2	9.4	20.8	20.7	15.9	49.5	45.9	37.9
CAPU-35	6.7	5.1	5.3	1.8	2.2	1.7	12.3	11.4	9.0	20.7	19.2	15.2	53.0	42.7	36.2
FI-32	5.2	4.6	6.6	2.0	2.4	1.5	10.5	11.0	9.9	17.8	18.6	16.8	42.3	41.3	40.0

Table 8. High expression test.

Press type/ Variety	Hours per 55 kg			Litres/hour			Litres per55 kg			Expression Rate (%)			Efficiency (%)		
	1	2	3	1	2	3	1	2	3	1	2	3	1	2	3
Camartec	12.7	11.2	10.2	1.2	1.3	1.0	14.6	15.0	9.7	24.7	25.4	16.5	58.8	56.4	39.2
CAPU-35	7.8	9.1	6.3	1.6	1.5	1.4	12.7	13.5	9.1	21.5	22.9	15.4	51.1	50.9	36.6
FI-32	8.3	12.1	10.6	1.3	0.9	0.9	11.2	11.4	9.4	18.9	19.2	15.9	45.0	42.7	37.9

From the results presented it is obvious that there is no significant difference between the two hybrid seeds. Both however, are superior to the open-pollinated Peredovik variety. Hybrids performed much better in all aspects of both tests; they give more oil and the expression rate was much better. But an especially marked difference can be observed for the efficiency, which for hybrids variety is from a minimum of 5% (for high production test) to 10% (for high expression test) better than for Perodovik. There was no major difference between the two hybrids used in the tests, however, PNR7225 seeds had slightly higher results for efficiency.

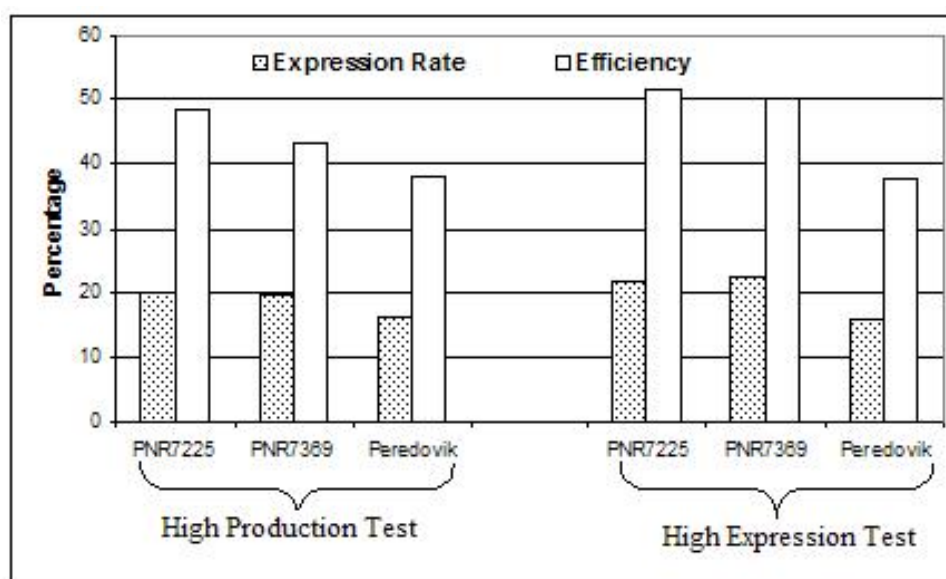

Figure 6. Expression rate and efficiency for different sunflower seeds.

It should be no surprise that in high production test the amount of oil expressed in an hour was higher than in the high expression test. Also, the number of hours spent on processing a bag (55 kg) of seeds is lower in the first test. However, probably the more important indicators of the quality of machines such as the expression rate and the efficiency are definitely higher in the second test, irrespective of the type of press used and variety of seeds. On average, the expression rate in the high expression test is almost 2% higher than in the high production test, and in case of efficiency the difference is more than 3%. Obviously, it is achieved by longer processing time which on average is 1.75 times longer in case of the high expression test (9.8 hours for high expression test as compared to 5.6 hours for a bag processed during high production test).

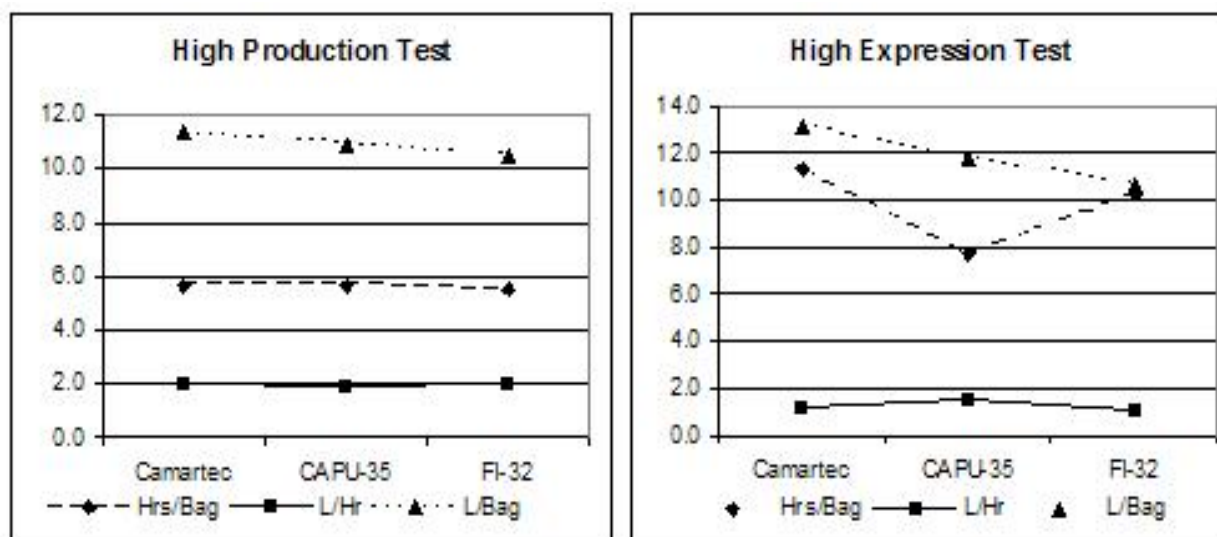

Figure 7. Comparison of press performance in terms of processing of seeds (hrs per bag) and oil expression (litres per hr and litres per bag).

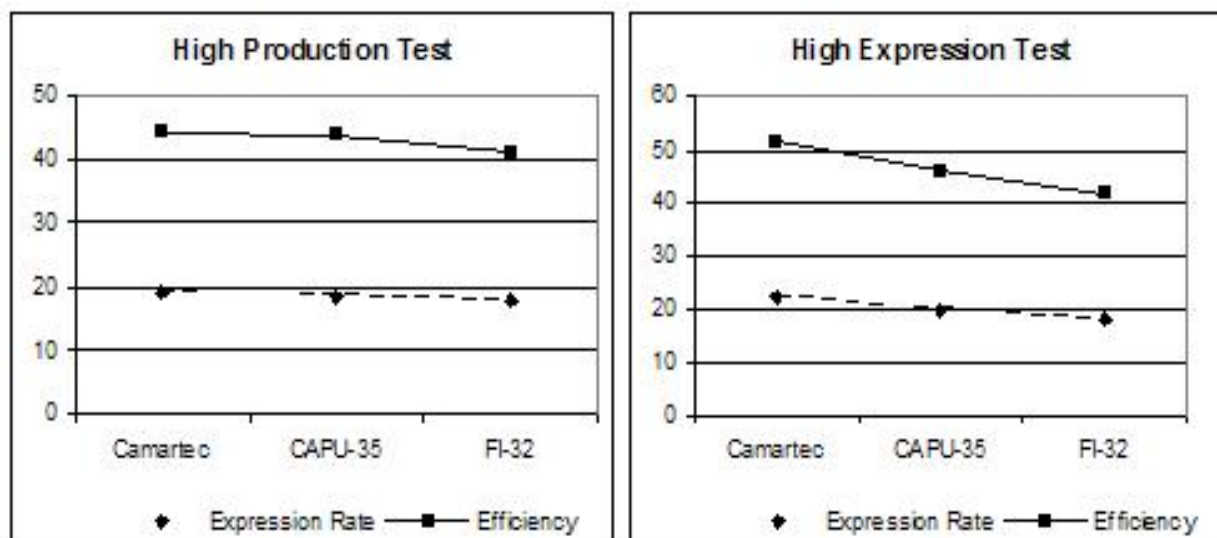

Figure 8. Comparison of press performance in terms of expression rate and efficiency.

There was a significant advantage of the Camartec and CAPU-35 designs over the FI-32 machine in terms of their performance. From Fig. 7 for the high production test it is observed that in terms of *oil expression* (litres/ hour) and *processing seeds* (number of hours required to process a bag of 55kg) all the machines performed similarly. However, for the high expression test the differences were significant with the CAPU machine being superior to the Camartec and the FI-32, which are performed alike. The main reason for the advantage of the CAPU-35 machine might be its largest piston diameter (40mm) as compared to Camartec (30mm) and FI-32 (32 mm), see Table 6.

In terms of the oil expression (litres of oil extracted from a bag of 55kg seeds) and also by the expression rate (in %) and the efficiency (in %) the Camartec machine is the best. The efficiency of FI-32 machine was the lowest, not even reaching the critical value of 20% (Fig. 8).

It is worth noting that CAPU-35 design gave the least difference between the two tests suggesting that the reasons for this might be the tapered cage design and the longest handle among the machines (Table 6). The first factor contributes towards maintaining a constant pressure in the cage and hence no difference between the results obtained from the two tests, while the second factor makes the machine rather difficult to operate at a high speed and therefore at a constant output.

On the contrary, the Camartec design appeared to provide the greatest difference between the two tests, as its cage is straight and it has almost the shortest handle and can be operated at high speed (Table 6). The straight cage cannot maintain constant pressure when the piston is doing the return stroke in order to feed it with the next portion of seeds, as the cake expands during that time and hence pressure drops from the optimum value for the oil expression. That is why the main objective for the operator, when conducting the high expression test is to retain the handle at its lowest position for about 2 seconds and therefore to maintain constant pressure in the cage for a longer time than it usually takes under the high production test. Therefore the prolonged time allowed more oil to leak out from the cage and hence higher expression rate.

From the results presented in Fig 6 it is obvious that there was no significant difference between the two hybrid seeds. Both however, were superior to the open-pollinated Peredovik variety. The higher value of the expression rate was achieved in the high expression test, although this was at the expense of an increase in the time taken to press a bag of 55 kg seeds. It may be possible to improve the mechanical and ergonomic design of the ram press, so as to achieve a high expression rate without extra pressing time for the pressing. There was a significant advantage of the Camartec and CAPU-35 designs over the FI-32 machine in terms of the expression rate and consequently in the litres of oil gained in an hour. Although the time taken in the first test to press 55 kg of seeds using the FI-32 machine is the lowest, its expression rate was the lowest, not reaching at least the value of 20%. The most efficient machine (in terms of oil expression) was the Camartec design. On the other side the CAPU-35 design gave almost the same results when subjected to the above tests.

The design of the ram press has not yet been fully optimized. Efforts should continue to design a better machine that combines a high expression rate with shorter time taken for processing of seeds. The numbers of reports on the mechanical analysis of the ram system are very limited (Loukanov and Uziak, 2001; Loukanov and Uziak. 2002; Uziak *et al.*, 2002). A consistent and profound analysis of these machines has not yet been performed.

There are several possibilities for improving the performance of the ram press machine, and these are:

- Proposing a new kinematics' configuration of the ram press mechanism,
- Varying the existing linkage proportions, introducing an offset in the slider-crank mechanism,
- Redesigning the cage-restriction cone sub-assembly for better performance.

All these opportunities should be carefully considered and tested in designing better ram press machines.

7. CONCLUSIONS

Based on the analysis of three ram press machines the Camartec machine had the best performance. The machine had the highest efficiency and also the highest expression rate in comparison with CAPU-35 and FI-32. The FI-32 machine was found to be ineffective, having even in the high expression test an expression rate below 20% irrespective of the type of seeds used. In terms of the speed of oil production the CAPU-35 design performed better than the other machines, however in the high production test its performance was similar to that of Camartec machine.

This paper presented few aspects of the oil expression technology when using ram press machines. It is intended to create an interest and awareness of the technology, which may help improving the development in the rural areas. As a low-cost, easy-to-use oil processing technology it may increase the production of, and the consumption of edible oil in rural areas.

8. REFERENCES

- ATI, 1985. Appropriate Technology International (ATI) and Lutheran World Relief (LWR) Program in Tanzania.
- Akinoso, R., J. Igbeka and T. Olayanju. 2006. Process Optimization of Oil Expression from Sesame Seed (*Sesamum indicum* Linn.). *Agricultural Engineering International: the CIGR Ejournal*, 8 (FP06 011).
- Akinoso, R., J. Igbeka, T. Olayanju and L. Bankole. 2006. Modelling of Oil Expression from Palm Kernel (*Elaeis guineensis* Jacg.). *Agricultural Engineering International: the CIGR Ejournal*, 8 (FP05 016).
- Asoegwu, S. and A. Asoegwu. 2007. An Overview of Agricultural Mechanization and Its Environment Management in Nigeria. *Agricultural Engineering International: the CIGR Ejournal*, 9.
- Bielenberg, C. 1996. Field Report on Ram Press Testing, Manufacture and Dissemination for Jatropha and Sesame in Senegal and Mali. Washington, D.C., Enterprise Works Worldwide.
- Elijah, E. 1997. An AT Dissemination Scheme in Northern Uganda is helping Local Farmers. In *Gate Magazine* 4.
- Henriksson, B. 1992. Test of Ram Presses. AGRITEX, Harare, Zimbabwe.

- Henriksson, B. 1993. Test of Ram Presses with Different Oil Seeds. AGRITEX, Harare, Zimbabwe.
- Loukanov I.A. and J. Uziak. 2001. Theoretical Analysis of an Offset Single Stroke Ram Press for Sunflower Oil Extraction. In *Proceedings of the Eighth IFToMM International Symposium on Theory of Machines and Mechanisms* Vol. 1: 165-170.
- Loukanov I. and J. Uziak. 2002. Theoretical and Experimental Analysis of Forces and Energy Utilization in a Ram Press Machine for Sunflower Oil Expression. *Mechanics of Machines* 41: 24-31.
- Mugeto, J. 1990. Bielenberg Ram Press Optimum Settings and Operating Procedures. In *Proceedings of ATI Workshop: The Bielenberg Ram Press and Small Scale Oil Processing*, Nairobi, Kenya.
- Nazare, R., B. Henriksson and R. Ngere. 1994. The Ram Press System. Research Report, AGRITEX, Harare, Zimbabwe.
- Nazare, R. and S. Nalumansi. 1996. Processing Vegetable Oil. A Reference Manual on Oil Seed Production and Processing using Ram Press. AGRITEX, Harare, Zimbabwe.
- Olayanju, T., R. Akinoso and M. Oresanya. 2006. Effect of Wormshaft Speed and Moisture Content on Oil Recovery from Beniseed. *Agricultural Engineering International: the CIGR Ejournal*, 8 (FP06 008).
- Uziak, J., I.A. Loukanov and J.D.G. Foster. 2002. A Simplified Model of an Offset Ram Press for Sunflower Oil Expression. *African Journal of Science and Technology*, 3(1): 61-68.