

An Improved Pole-and-Knife Method of Harvesting Oil Palms

D.A. Adetan, L.O. Adekoya and K. A. Oladejo
Department of Mechanical Engineering, Obafemi Awolowo University, Ile-Ife, Nigeria.
e-mail: aadetan@yahoo.com; dadetan@oauife.edu.ng

ABSTRACT

A modified pole-and-and-knife (MPK) method of harvesting oil palms was designed and fabricated. The method was tested along with two existing methods, namely the bamboo pole-and-knife (BPK) and the single rope-and-cutlass (SRC) methods. Test results showed that the MPK method was superior to the other methods in reducing the time spent in searching for and collecting scattered loose fruits (and hence the harvesting time), increasing the recovery of scattered loose fruits, eliminating the waist problem of the fruit collectors and increasing the ease of transportation and use of the harvesting pole.

Keywords: Oil palm harvesting, catchment platform design, harvesting pole design, harvesting times.

1. INTRODUCTION

The oil palm (*Elaeis guineensis*) is a tree without branches but with many wide leaves (or fronds) at its top (or crown). It has become the world's number one fruit crop because of its unparalleled productivity; it is simply the most productive oil plant in the world (Butler, 2006). The oil is considered as being healthier for human consumption than hydrogenated vegetable oils. Indeed, there is a growing awareness of the dangers associated with the consumption of trans fats (hydrogenated vegetable oil) and this has made palm oil much more popular as an alternative ingredient in packaged grocery products; it has also gained credence as a cooking oil (Whole Foods Market, 2006). However, oil palm harvesting still defies the best attempts at mechanization (Russ, 1998).

Generally, for fruit crops, the majority of the mechanical harvesting systems utilized today are shake-catch systems (Futch et al., 2006). Oil palm defies this method of harvesting, which is applicable to other fruit trees, because the fruits are compactly packed in bunches which are hidden in leaf axils in crowns that may be over 12 m above the ground. It is therefore bunch-harvested. Each tree is visited for harvesting every 10 – 15 days as fruit bunches ripen throughout the whole year (Kwasi, 2002). The stalks of the palm fronds underlying a bunch are first cut; thereafter, the stalk of the bunch is cut and it is allowed to fall freely onto the ground. Some fruits scatter in the process and they are hand-picked.

Timeliness of harvesting is very crucial to the quality and quantity of oil yield from the fruits. The under-ripe fruit will yield lower quantity of oil while the over-ripe one will yield oil with higher free fatty acid (ffa) content i.e., lower quality oil (Harcharan, 1976). Therefore, harvesting schedule will depend on the ripening of fruits as observed on plantations (Owolarafe and Arumughan, 2007). When a fruit is fully ripe, it loosens itself from the bunch and drops on the ground or it becomes easily detachable. Thus, the ideal system of harvesting

would be to collect loose fruits daily from the ground (Harcharan, 1976) or to examine them daily for easily-detachable fruits (Hartley, 1977). In practice however, these ideals are clearly impossible as the higher percentage of the fruits would just over-ripen and rot away on the tree crown if they are not bunch-harvested. A fruit bunch is normally considered as ripe enough for harvesting when a few fruits have loosened themselves from the bunch and dropped on the ground.

Locally, short trees within arm-reach are harvested using either the cutlass or the chisel to cut the bunches and fronds. On the other hand, very tall trees above 9 m in height are harvested using either the single rope-and-cutlass (SRC) or the double rope-and-cutlass (DRC) method. The SRC method is more common because it is relatively much faster though less safe (Ironbar, 1981). In this method, the harvester manually climbs the tree by the use of a rope tied around the tree and his torso. Once within arm-reach of the crown, the harvester uses a cutlass to cut the fronds and bunches. Medium-height trees beyond arm-reach up to a height of about 9 m are harvested using the bamboo pole and knife (BPK) method. In this method, a Malaysian knife, which is a curved knife with the sharp edge along its convex side, is attached to the end of a bamboo pole. The length of the pole depends on the average height of the trees on the plantation plot to be harvested. The harvester stands on the ground while the pole and knife are raised to the tree crown in order to harvest the bunches. Yet another method is the Aluminium pole and knife (APK) method. In this method, a 40 mm diameter aluminium tube replaces the bamboo pole of the BPK method. It works very well and even faster than the BPK method for trees of height below 5.5 m. Above this height, bending of long harvesting poles that carry relatively heavier cutting knives on top constitutes a very serious problem as it becomes very difficult to engage the stalks of palm fronds and bunches. Harvesters' hand-pole slippage while cutting with the pole also constitutes another serious problem as the harvester inevitably sweats on his palms while on the job. For these reasons, the APK method is yet to enjoy wide application. Generally, once the harvester reaches the tree crown, it is a lot easier to cut (fronds and fruit bunches) using the cutlass than it is using the Malaysian knife.

Indeed, a lot of time and energy (and therefore production cost) goes into oil palm harvesting. Such an enormous amount of energy is required for harvesting oil palm that even cutting a single frond alone, using the sickle cutter (the Malaysian knife), could require the exertion of a force as much as 18,048 N for the most matured frond (Jelani et al., 1999). Further, Bevan and Gray (1969) reported that in a study on palms aged between 9 and 25 years in Malaysia, between 43.5 and 45.4 % of the total annual man-days is spent on harvesting. Harvesting from the older trees took more man-days. The situation, most likely, has not changed today because harvesting is still being done manually.

Many attempts have been made to reduce the drudgery of the harvesting of oil palms. Webb (1976) worked on an oil palm tree climbing cycle. Test results showed that the cycle was not efficient for palm trees and it was not comfortable for the harvester to use. A lot of energy and time was required by the method.

Hartley (1977) reported that harvester-carrying booms mounted on track or high-floatation wheel tractors have been tried in Honduras and Costa Rica. The booms take the harvesters to the crowns of palms up to 12 m in height, and the bunches are cut to fall into a trailer drawn behind the tractor. The economics of using this method as compared to the existing methods is yet to be established.

Adetan and Adekoya (1995) reported investigations carried out on two methods of manual harvesting of oil palms in Nigeria, namely the BPK and the SRC methods. The results of this investigation showed, among other things, that (i) the search for and the collection of the detached and scattered fruits was never fully accomplished, because a number of scattered fruits remain hidden by the low vegetation around the tree base and it was impossible to know how many fruits were detached from the bunches and hence when the search and collection should be terminated; (ii) the fruit collector always complained of waist pains; (iii) the bending of long and heavy poles made it difficult for the BPK method to be comfortably used in harvesting tall trees; (iv) the risks of accidental falls and insect bites made the SRC method unattractive to harvesters; and (v) transportation of heavy BPK method poles to the distant plantations took a lot of the harvester's time and energy and thus drastically reduced his rate of harvesting; this could have been largely responsible for the report by Chirs (1986) that harvesting declined as distances (from farm settlements) to the plantations increased.

Pierce and Cavalieri (2002) opined that improving labour productivity, health and safety represents a major opportunity for reducing production costs. Also, the report by Adetan and Adekoya (1995) further established that because climbing before cutting substantially reduced the SRC harvesting rate and that much risk (including fatal falls) is involved in climbing, the pole-and-knife method is both faster (more productive) and safer than the rope-and-cutlass method. Thus the report recommended that research effort should preferably be directed towards improving the pole-and-knife method by (i) redesigning the harvesting pole to reduce its weight, minimize bending and increase the ease of its transportation and (ii) introducing a fruit catchment platform to eliminate or drastically reduce the fruit collecting time, ensure virtually 100% scattered fruits recovery and eliminate the waist pain experienced by fruit collectors. Currently scattered loose fruits can account for up to 14% of the total harvest and estimates from studies in Papua New Guinea suggest that between 60-70% of the scattered loose fruits is being left to rot away on the ground, representing a substantial loss of revenue for the industry. Page (2004), in his own report, suggested that up to 70% of the scattered fruits waste away.

The main objectives of this work were therefore:

- (i) to design a fruit catchment platform to eliminate or drastically reduce the fruit collecting time, ensure virtually 100 % scattered fruit recovery and eliminate the waist pain experienced by the fruit collectors;
- (ii) to design a harvesting pole with reduced weight and bending, and increased ease of transportation;
- (iii) to study oil palm harvesting times using the modified pole-and-knife (MPK) method (consisting of the fruit catchment platform and the redesigned pole), the BPK and SRC methods;
- (iv) to compare the average times spent on the separate harvesting activities while using these three methods of harvesting.

2. MATERIALS AND METHODS

2.1 Preliminary Investigation

In order to specify dimensions of the fruit catchment platform, preliminary investigations were carried out to determine the distances of fall of the fruit bunches and the trunk base

diameters of the palm trees. The distance of fall was defined as the distance between the tree and the point of impact of the fruit bunch on the ground after cutting. It was measured with a measuring tape. After 150 replications on 10 randomly chosen plots, the mean and the standard deviation for the statistic were obtained as 1.06m and 0.26m respectively. The trunk base circumference was measured by wrapping the tape around it. The circumference value so-obtained was divided by π to obtain the corresponding value of the trunk base diameter. After 50 replications, the mean value was obtained to be 0.47m.

2.2 Design of the Fruit Catchment Platform

The fruit catchment platform (see Fig. 1) was designed based on the following criteria:

- (i) it must be portable;
- (ii) it must be tough enough to withstand the impact by the bunches falling from heights that could be in excess of 10m;
- (iii) it must catch all the harvested bunches and scattered fruits; and
- (iv) it must be able to engage the tree trunks.

Based on the above criteria, and the data from the preliminary investigations, the catchment platform was designed as a square (2 m x 2 m) mat of 40 mm thick high density foam sandwiched between a tough Polyethylene Teraphthalate based tarpaulin material on top and a fairly tough Nylon (Polyamide) material below. It was sewn along its two centre lines. To

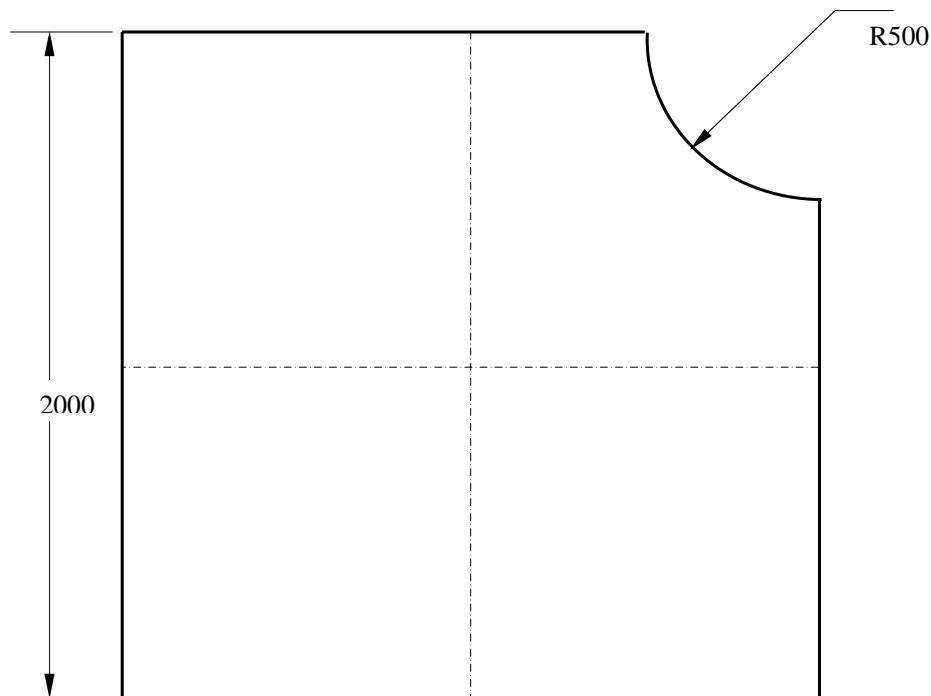

Figure 1: Sketch of the catchment platform of the MPK method (dimensions in mm)

ensure proper engagement with the tree trunk, a 0.5 m radius arc was cut at one of the corners. The tarpaulin was tough enough to withstand impact by the bunches while the polythene prevented moisture absorption by the catchment platform. The foam made the spreading and folding of the platform easy and also helped to absorb some of the kinetic energy of the falling bunches. The absorption of some of the kinetic energy of the falling bunches has two functions. The first was to reduce the detachment of fruits from the bunches and also ensure that the few detached fruits do not possess enough kinetic energy to be dispersed from the catchment platform; the second was to reduce the severe damages inflicted on the fruits as they impacted the ground. The reduction of severe damages to the fruits is likely to substantially reduce the free fatty acid (ffa) level of the oil produced from them, leading to oil of higher quality.

2.3 Design of the Harvesting Pole

The modified harvesting pole (see Fig. 2) was specified according to the following design criteria.

- (i) it must be easy to carry,
- (ii) bending of the pole must be minimized so that engagement of fronds and bunch stalks would be easy,
- (iii) it must be able to harvest both short and tall trees.

Based on the above criteria and relevant data from Adekoya and Makinde (1990), the harvesting pole was designed to consist of three sections made from three lengths of aluminium pipes. By treating the pole as a cantilever, deflection analysis was carried out (Juvinal, 1967) on various lengths and diameters of aluminium poles to determine the sizes to procure for the construction. The topmost section of the pole was made from a 40 mm outer diameter and 35 mm inner diameter aluminium pipe and it carried the knife. It was 3.5 m in length (including the length of the knife which was 0.35 m long). The middle and bottom sections were each made from 2.1 m lengths of 60 mm outer diameter and 52 mm inner diameter aluminium pipe. The top and middle sections, when connected together, was 5.6 m long while the three sections together measured 7.7 m in length. Holes were drilled in the pipes to reduce their weights to desired levels. An externally threaded galvanized iron pipe was coupled to the bottom of the top section using bolts and nuts while an internally threaded galvanized iron pipe was similarly coupled to the top of the middle section. The top and middle sections were then connected together by screwing these threaded galvanized iron pipes onto themselves. The middle and bottom sections were connected to each other using a pair of curved plates and bolts. Each plate was curved such that it wrapped around about one-third of the circumference of the aluminium tubes when coupled to the tubes. Two short lengths of 10 mm diameter steel rods were welded radially to the convex side of each plate (see Figure 2). These rods fit into holes in the tubes and thus assist in holding the tubes together firmly. The curved plates were fabricated from 4 mm thick mild steel sheet.

The three sections are easier to carry to and from the plantation for harvesting than one long bamboo pole because (i) they could easily be disconnected and packed together and (ii) they are much lighter in weight. Because the length was variable, the aluminium harvesting pole will be able to conveniently harvest trees on different plots.

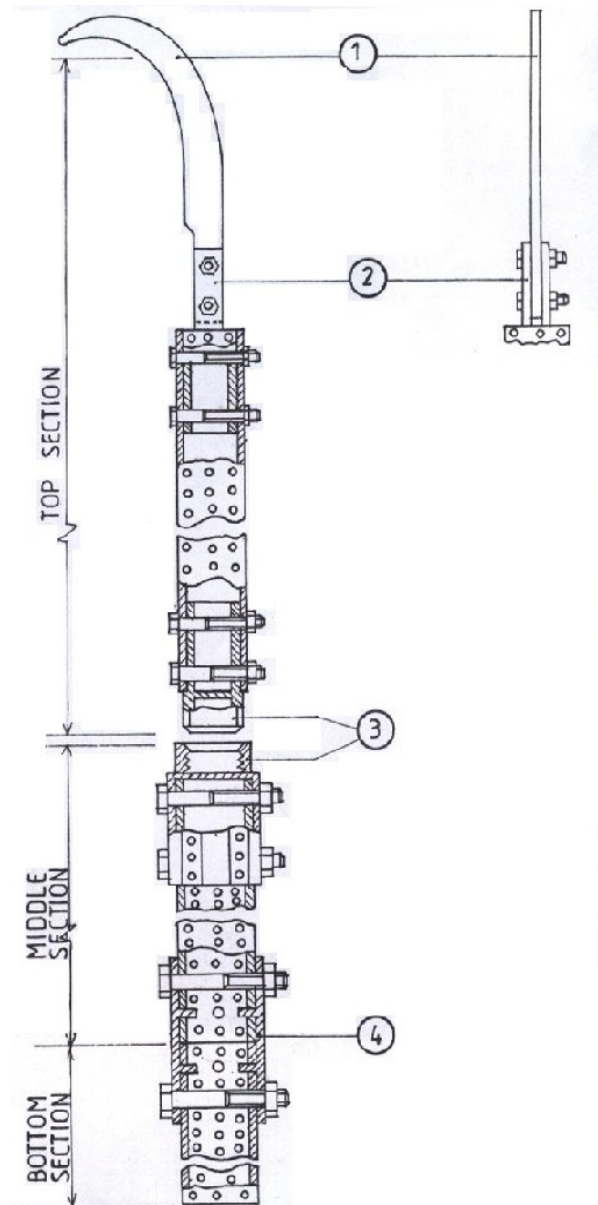

Figure 2: Sketch of the aluminium pole of the MPK method of harvesting the oil palm; 1, malaysian knife; 2, knife carrier; 3, threaded pipes-and-bolt coupling between top and middle sections; 4, curved plate-and-bolt coupling between middle and bottom sections.

2.4 Field Tests

By local practice, harvesting of oil palm is carried out by a crew of three, comprising one bunch and frond cutter who also stacks the cut fronds along the row, one fruit collector who searches for and picks both the fruit bunches and the scattered loose fruits and a transporter

who uses a head pan to carry the fruit bunches and the loose fruits to the truck collection centres on the field.

Based on previous work (Adetan and Adekoya, 1995), harvesting of oil palm was broken down into five separate activities which can be classified as:

- (i) locating, reaching and cutting of the ripe fruit bunches and underlying fronds,
- (ii) stacking of the cut fronds along the row,
- (iii) searching for and collecting the cut fruit bunches and the scattered loose fruits from the ground,
- (iv) transporting the fruit bunches and the loose fruits to the collection centres on the field and
- (v) loading the fruit bunches and the loose fruits into vehicles.

In this study, data were collected only on the first three activities.

Tests were carried out on the MPK, BPK and SRC methods on randomly selected plots on the oil palm plantations of the Nigerian Institute for Oil Palm Research (NIFOR), Benin-City, Nigeria, during a high-crop period, March and April. Depending on the height of trees on a plot, the top section, top and middle sections or all the three sections of the MPK were used for harvesting.

On each harvesting day, a harvesting crew was chosen while labour was being allocated to the plots in the morning and the chosen crew was followed to whichever plot was assigned to it and thereafter monitored. By this method, twenty four different crews were randomly used during the duration of the tests, eight crews for each method of harvesting. The 24 crews harvested a total of 264 trees during the period of the tests. Because it was envisaged that his job will now be reduced, the fruit collector was allocated the job of moving the catchment platform from tree to tree in the MPK method. The average age and weight of members of the harvesting team that were involved in the tests are 36 years and 70 kg respectively. They were all men with no physical disability or ailment.

A stopwatch was used to measure the time spent per tree during each activity of the MPK, BPK and SRC methods. For the SRC method, the times of interest were t_2 , t_3 , t_c , t_d , and t_u while for the MPK and BPK methods, they were t_1 , t_2 , and t_3 where:

- t_u = time for tying the climbing rope around the trunk of the oil palm tree and the cutter and for climbing the tree up to the crown, seconds;
- t_c = time for cutting all ripe bunches and underlying fronds on a tree, seconds;
- t_d = time for climbing down from the tree crown and untying the climbing rope, seconds;
- t_1 = time per tree for raising up the harvesting pole, cutting the fronds and ripe fruit bunches and lowering the pole in the MPK and BPK methods. It is equivalent to the sum of t_u , t_c and t_d in the SRC method, seconds;
- t_2 = time for stacking the cut fronds per tree, seconds; and
- t_3 = time for searching for and locating the loose fruits and collecting them together with the fruit bunches per tree, seconds. In the MPK method, it includes the times for spreading the catchment platform, funnelling the loose fruits on it into the head pan (for subsequent transportation to fruit collection points on the field) and folding the catchment platform.

Other evaluation statistics which were computed from the measured ones are the total effective harvesting time per tree (t_T), t_1 as a percentage of t_T (p_{T1}), t_2 as a percentage of t_T

(p_{T2}) and t_3 as a percentage of t_T (p_{T3}). Unquantifiable field observations that affected the comfort of the harvesting crew were also noted.

3 RESULTS AND DISCUSSION

Each day's result was taken as a data point. Daily averages of t_u , t_c , t_d , t_1 , t_2 and t_3 were calculated. The total effective harvesting time per tree, t_T , was also computed as the sum of t_1 , t_2 and t_3 . The average of each of the above parameters was calculated over the period of investigation and tested for significance. The mean values are shown in Table 1.

Though there was no statistically significant difference between the time t_1 for the three methods (at 0.05 significance level), it was averagely highest for the SRC method. The explanation is that climbing up and down the tree takes much time and becomes progressively tiring especially after the harvester has been on the field for a while. The time t_1 for the MPK method was smaller than that for the BPK method because the variable length of the pole made it easily adaptable for harvesting different plots, since the heights of the trees were different for different plots. By contrast, a long bamboo pole easily harvested tall trees but was very clumsy when used in harvesting short trees. Conversely, a short bamboo pole easily harvested short trees but was impracticable in harvesting tall trees.

There was no statistically significant difference between the time t_2 for all the methods. This is expected because the time t_2 is not dependent on the harvesting method, but rather on the age of the tree and the season of the year (which affect the number of leaves pruned before cutting the bunches).

Table 1: Summary of results of tests on MPK, BPK and SRC methods of harvesting oil palm.

Quantities	Overall Averages		
	MPK Method	BPK Method	SRC Method
t_u (s)	-	-	90
t_c (s)	-	-	271
t_d (s)	-	-	53
t_1 (s)	259	357	415
t_2 (s)	70	87	115
t_3 (s)	57	199	449
t_T (s)	386	643	979
P_{T1} (%)	67.1	55.5	42.4
P_{T2} (%)	18.1	13.5	11.7
P_{T3} (%)	14.8	31.0	45.9

Expectedly, the time t_3 gave the most important result. It shows that the time needed for collecting the scattered loose fruits in the MPK method was averagely much less than in the BPK method and indeed statistically significantly much less than that required in the SRC method. The simple explanation is that fruits were effectively constrained by the catchment platform of the MPK method and as such there was no need for endless searches for them.

Most of the time that made up t_3 for the MPK method was actually spent in spreading and positioning the catchment platform at the base of the tree trunk before harvesting the bunches, and folding the catchment platform for discharging the loose fruits into head pans after harvesting the bunches. This time obviously depended on the ease with which the platform could be handled. It was very easy to handle because it was made from lightweight materials. Thus, the catching platform of the MPK method was a very effective means of cutting down the time spent in gathering (picking) the loose fruits that were scattered while harvesting the oil palm. In addition, it ensured that virtually 100% of the detached loose fruits were recovered. Cumulatively, this will lead to higher recovery of harvested bunches.

The total effective harvesting time, t_T , was significantly less for the MPK method than for both the BPK and the SRC methods. This is because t_1 and t_3 for the MPK method are considerably less than those for the other two methods.

The following observations were also made in the field about the MPK method:

- (i) Transportation of the harvesting pole was easier. For transportation purposes to the field from the farm centre, the three sections of the pole were tied together and carried by the cutter while the catchment platform was rolled up and carried by the fruit collector. Alternatively, both the pole and the platform were placed on a bicycle as was sometimes done with the BPK method. Since none of the sections of the pole of the MPK method was longer than 3.5 m, transportation was much easier than that of a bamboo pole with a length equal to that of the three sections put together.
- (ii) Tall trees of up to about 9 m height were more easily harvested with the MPK method than with the BPK method. This is because MPK pole deflection was smaller and as such bunches could be engaged with less difficulty.
- (iii) Because the fruit collector of the MPK method spent very little time bending to recover scattered loose fruits, he never complained of waist pain which was a major complaint of the fruit collectors of the BPK and SRC methods.

4. CONCLUSIONS

The conventional bamboo pole of the BPK method was replaced with a designed aluminium pole and augmented with a catchment platform resulting in the MPK method of harvesting oil palms. Field tests of the MPK, BPK and SRC methods showed that the MPK method was superior to the other two methods in reducing the time spent in searching for and collecting scattered loose fruits. The method also ensured virtually 100% recovery of the scattered loose fruits. It also eliminated the back pain problem of the fruit collector.

5. ACKNOWLEDGEMENT

The authors thank the authorities of the NIFOR, Benin City, Nigeria, for granting permission for the use of its plantations for this research.

REFERENCES

- Adekoya, L.O. and Makinde, A. 1990. Data acquisition for the mechanization of oil palm harvesting, *Nigerian Journal of Engineering and Technology* 9 (1): 16 – 28.
- Adetan, D.A. and Adekoya, L.O. 1995. Comparison of two methods of manual harvesting of oil palm (*Elaeis guineensis* Jacq). *Tropical Agriculture* 72 (1). 44 – 47.
- Bevan, J. W. L. and Gray, B. S. 1969. *The organization and control of field practice for large-scale oil palm plantings in Malaysia*. Incorporated Society of Planters, Malaysia.
- Butler, R. A. 2006. Why is oil palm replacing tropical rainforests? Why are bio fuels fuelling deforestation? http://news.mongabay.com/2006/0425-oil_palm.html. 14th October, 2006.
- Chirs, O. B. 1986. An impact analysis of the development of the rural road system on the production of oil palm in Imo State, Nigeria. *Agricultural Systems* 19(2) pp141 – 152.
- Futch, S. H., Whitney, J. D., Burns, J. K. and Roka, F. M. 2006. Harvesting: From Manual to Mechanical. HS-1017, one of a series of the Horticultural Sciences Department, Florida Cooperative Extension Service, Institute of Food and Agricultural Sciences, University of Florida. <http://edis.ifas.ufl.edu>. 22nd October, 2006.
- Harcharan, S. K. 1976. *The oil palm industry of Malaysia: an economic study*. Penerbit University Malaysia, Kuala Lumpur.
- Hartley, C.W.S. 1977. *The Oil Palm*. Longmans Green and Company: pp 1 – 19, 459-561.
- Ironbar, J. E. 1981. *Report on my one year in office as the officer in charge of Harvesting Unit, NIFOR*. An unpublished report, NIFOR, Benin-City, Nigeria. pp 1 – 8.
- Jelani, A. R., Ahmad, D., Hitam, A., Yahya, A. and Jamak, J. 1999. Reaction force and energy requirement for cutting oil palm fronds by spring powered sickle cutter. *Journal of Oil Palm Research*. Vol.11 (2). pp 114 – 122.
- Juvinall, R.C. 1967. *Engineering considerations of stress, strain and strength*, McGraw-Hill Book Company, New York. pp 142-164.
- Kwasi, P. 2002. *Oil palm processing*. FAO Agricultural Services Bulletin 148.
- Owolarafe, O.K. and Arumughan, C. 2007. “A review of oil palm fruit plantation and production under the contract-growers scheme in Andhra Pradesh and Tamil Nadu states of India” *Agricultural Engineering International: the CIGR Ejournal*. Invited Overview No. 4, Vol. IX. March, 2007.
- Page, W. 2004. A mobile income benefits everyone. *Partners in Research for Development*. [http://www.aciar.gov.au/web.nsf/att/ACIA-6NE6H8/\\$file/Partners%203%20PNG%20stories.pdf](http://www.aciar.gov.au/web.nsf/att/ACIA-6NE6H8/$file/Partners%203%20PNG%20stories.pdf). 23rd October 2006.
-
- D. Adetan, L. Adekoya and K. Oladejo. “An Improved Pole-and-Knife Method of Harvesting the Oil Palm”. *Agricultural Engineering International: the CIGR Ejournal*. Manuscript PM 06 027. Vol. IX. June, 2007.

- Pierce, F. J. and Cavalieri, R. P. 2002. "Globalization and traceability of agricultural production: the role of mechanization". *Agricultural Engineering International: the CIGR Journal of Scientific Research and Development*. Invited overview paper Vol. IV. Presented at the Club of Bologna meeting, July 27, 2002 Chicago, IL, USA.
- Russ, H. 1998. Oil palm (*Elaeis guineensis*). *The Australian New crops Newsletter*. No. 10. <http://www.newcrops.uq.edu.au/newslett/ncn10214.htm>. 14th October 2006.
- Webb, B.A. 1976. The development of suitable fruit harvesting system to improve the efficiency of oil palm production. *Proceeding of Agriculture Oil Palm conference, Kuala Lumpur*: pp 741 – 752.
- Whole Foods Market. 2006. Palm oil. <http://www.wholefoodsmarket.com/healthinfo/palmoil.html>. 23rd October, 2006.