

A Stochastic Approach for Modeling Treatment and Diagnosis of Attention Deficit Disorder

Carlos Acevedo-Estefanía * Carlos Torre[†] Ariel Cintrón-Arias [‡]
 Carlos Hernández-Suárez [§] Sophonie Nshinyabakobeje [¶]

August 9, 2002

1 Abstract

Attention deficit disorder (ADD) is the most common type of mental disorder affecting children. It is estimated that around 6% of the total United States population is affected by this disorder. The exact causes have not been clearly identified, although studies show that there is a genetic component. Our aim is to build an individual-based stochastic model and use it to evaluate the efficiency of the current treatment for ADD. We use a Markov chain approach to model the transition probabilities through different states in a population of children. The asymptotic distribution of the population of children across various states is computed as a function of the limiting probability of the transition probability matrix. The ratio of the proportion of children without the disorder to children with the disorder as a function of the probability of treatment efficiency is simulated and implications of variations on this ratio as a function of key parameters is described. The importance of early and efficient treatment as well as diagnosis are highlighted through sensitivity analyses performed on the model.

2 Introduction

"Attention deficit hyperactivity disorder (ADHD) is a neuropsychiatry diagnosis for children presenting with significant problems in the central nervous system (CNS) regulation of attention span, impulsiveness, and motor over-activity" [?]. It arises early in childhood, typically between 3 and 7 years of age. "The disorder is relatively stable over time and persists through adolescence and into adulthood in more than half the cases" [?]. Throughout this paper we will be talking about ADD and ADHD as the same disorder, but for our purposes, we define them as an attention deficit disorder, but they are different severities of the same deficiency.

This disorder reduces the level of concentration of glucose in the pre-frontal cortex of the brain making the person less attentive in any given situation. In other cases where that part of the brain is not functioning correctly, the side of the brain that deals with hyperactivity is always in use, making this individual constantly hyperactive one. There have been studies done to determine the

*University of Texas-Austin(cacevedo@math.mail.utexas.edu).

[†]Cornell University(cat24@cornell.edu).

[‡]Cornell University(ariel@cam.cornell.edu).

[§]Universidad de Colima(cmh1@cornell.edu).

[¶]Cornell University(sn44@cornell.edu).

behavior of this disorder and the etiology of it. Although there is no exact understanding, it has been shown that it is partially hereditary. It is important to note at the outset that ADD is not a unitary illness. "It is likely that a number of different pathways that include both genetics and environmental factors contribute to the expression of its symptoms" [?]. "Findings from a number of twin studies are consistent with a genetic hypothesis as are the results from a segregation analysis that suggested that ADHD might be the result of a single major gene with incomplete penetrance" [?]. "Notably, twin studies show that heritability of ADHD to be about 80%, indicating that the effect of genes is substantial" [?].

There exist several defining guidelines observed by the organizations, in charge of the clinical diagnosis of a child with ADD. "Because children typically underreport ADHD, and they frequently do not appear inattentive or hyperactive during a structured office visit, information obtained from parents and teachers is often required to make an accurate diagnosis" [?]. Symptoms criteria used to clinically diagnose an individual as having the disorder vary from country to country. These guidelines in the US are met around 50% of the cases. The US government spends over 3 billion dollars yearly in order to try to give the children who are diagnosed the correct treatment and education. For some reason a normal child can show all the symptoms necessary of being diagnosed as having the disorder, but just be a hyperactive child.

There exists a manual, Diagnostic Statistical Manual(DSM-IV), which defines several symptoms that the therapist needs to observe in the child in order to give a correct diagnosis. These symptoms have to appear for more than 6 months and in two different living situations, such as school, house, etc. Usually once the child is diagnosed, s/he is analyzed and from there is determined which is the best treatment. Most of the time they are put on medication, which alters the functioning of the brain, or if the disorder appears to be less severe, then the child is given therapy. There has been a 45% decrease in visits where no drugs are prescribed, from 23.4% in 1994 to 12.8% in 1996 [?]. There is a high percentage of individuals that do not meet the criterias to be clinically defined as having ADHD, but still are given medication and treated as individuals that have the disorder. In a study done by Bussing et al.(2000), it was found that of the children which do not have the disorder 66% of them were still being treated with medication. Since this disorder is not considered a high risk disease, and since it is not well defined, medical insurance companies do not cover the expenses in most of all cases. Low-income families have a lower probability of ever getting the adequate treatment to control the disorder. ADHD does not affect individuals in any specific way. This is one of the main problems of diagnosing the disorder, there exists a wide array of the severity of the disorder and is difficult to understand the point where a hyperactive child is not just hyperactive, but has a brain response deficiency. On a recent report[?] researchers defined the psychopharmacology of ADD, and presented a series of results that are not as reassuring as they expect them to be. They portrayed ADD as one of the most effectively treated child disorders. Treatment studies and clinical experiences suggested that there exists a short term effectiveness of the pharmacological strategies, along with an increased in the percentage of children being prescribed medication, a recent study shows that there exists an undertreatment of the disorder, of 5% of children which met criteria for ADHD, only 13.6% of those children were being treated correctly. This undertreatment of the disorder and misdiagnosis of the symptoms lead us to try to give an explanation of the problems that these individuals are facing.

Based on a series of complications above mentioned, we will use a stochastic model to get more insight into the efficiency of the treatment. One of our main goals is to set up a base for a regression analysis model in order to estimate the ratio of a child without disorder to an child with the disorder, given the efficiency of the treatment. The outputs of our simulations are used to create a regression equation that gives us a good estimate of the probability of an child with the disorder to one without the disorder.

3 Methodology

We employ a finite state Markov chain to model the dynamics between different classes of individuals for the population of interest. The limiting probability of this Markov chain is used to compute the expected time that an individual spends in a class. The expected time spent in a class is then utilized to estimate the distribution of the population among all classes in the long run. It is of our interest to simulate the ratio of children without ADD to children with the disorder as a function of the probability of inefficient treatment.

In the following, n -vectors are considered as columns vectors, thus if $\pi \in \mathbf{R}^n$, we then write $\pi^T = (\pi_0, \pi_1, \dots, \pi_{n-1})$. Let X_t denote a Markov chain with finite state space Ω , where $\Omega = \{0, 1, 2, \dots, n\}$. Let us define

$$\pi_j = \lim_{m \rightarrow \infty} P_{ij}^m$$

where

$$P_{ij}^m = P\{X_{s+m} = j / X_s = i\}$$

this is, P_{ij}^m denotes the probability of passing from state i to state j after m -steps. It follows from Chapman-Kolmogorov equations that, for a fixed j we have,

$$\pi_j = \sum_{k=0}^n \pi_k P_{kj} \quad (1)$$

Let P denote the n -by- n matrix of one-step transition probabilities, whose ij -entry is given by P_{ij} . In view of (1), we can easily see that the vector π satisfies,

$$\pi^T = \pi^T P \quad (2)$$

Also, letting $\mathbf{1} \in \mathbf{R}^n$, with $\mathbf{1}^T = (1, 1, \dots, 1)$, recall that,

$$\mathbf{1}^T \pi = 1 \quad (3)$$

The vector π is known as the limiting probability. Next, let $J = \mathbf{1}\mathbf{1}^T$, in other words, all entries of J are equal to 1. Let I denote the n -by- n identity matrix, and $Q = \mathbf{1}\pi^T$, this is to say, every row of Q is equal to π^T . Thus, it follows that,

$$Q + QJ = QP + QJ$$

hence, in view of (3) and definition of J , we obtain,

$$J = Q(P + J - I)$$

therefore, provided that $(P + J - I)$ is nonsingular, an expression for π is given by,

$$\pi^T = \mathbf{1}^T (P + J - I)^{-1} \quad (4)$$

Observe that by using *Sherman-Morrison-Woodbury* formula an expression for the inverse of $P + J - I$ can be found. In fact, the existence of such an inverse relies on the nonsingularity of $P - I$, please see [?] for details. We are employing a closed-loop stochastic model in accordance with the approach proposed by Hernández-Suárez in [?]. Therefore, the dead-state and the newborn-state are both represented by $\Delta \in \Omega$. An individual's life span is then modeled by the trajectory of transitions between different states until it returns to Δ .

Henceforth, fix i , $i \in \{0, 1, 2, \dots, n - 1\}$.

Let E_i be the expected time that an individual spends at a class i , which is given by

$$E_i = \frac{\pi_i}{\pi_n} \frac{1}{\delta_i} \quad (5)$$

where δ_i denotes the rate at which an individual leaves class i .

Now, let π_i^* denote the stationary probability that an individual is at the i -th class, which is given by,

$$\pi_i^* = \frac{E_i}{(\sum_{j=0}^{n-1} E_j)} \quad (6)$$

The ratio of children without ADD to children with the disorder, is modeled by an expression as the following,

$$r = \frac{\pi_i^*}{\pi_j^*}$$

where $i \neq j$. In order to implement numerical simulations we let r be a function of c , the probability of inefficient treatment, this is to say,

$$r = r(c)$$

Our approach is the first effort for having a way to estimate the ratio of people without the disorder to people with it once the probability of treatment efficiency is provided. A regression analysis can be based on our simulations to obtain such an estimate.

4 Models Assumptions and Parameters

Parameters for the three models investigated in this study are presented in Table 1. A number of assumptions are made in this study. We consider a population of children with age varying from 3-18 years. We further assume that state Δ closes the open-loop system, meaning that the input (in-born children) comes from it and the output (adult-people) goes to it. Thus, Δ is a reflecting state, in other words, the transition between Δ and another state in the system has probability one. In the following, we present models where the transition is given from Δ to X_0 (this state will be defined in the following paragraphs).

4.1 4-State Model

In this model we have the following states: children not expressing the disorder, children with ADD, children receiving treatment, and the adult state. By children who are not expressing the disorder, we mean children who do not have ADD, as well as people who had it and are recovered through treatment. Notice that the efficient treatment for ADD does not fix the genetic disorder, it only relaxes the limitations of the affected individual to facilitate his/her adaptation in society.

Let X_0 denote the state of functional children. Let X_1 be the state of children with ADD. Let T denote the treatment state, and Δ be the adult state.

Recall, that Ω denotes the finite-state space. Thus,

$$\Omega = \{X_0, X_1, T, \Delta\}$$

Parameter	Definition
μ	rate at which a child becomes an adult
σ	rate of acquiring ADD
ϕ	rate of finishing treatment
γ	rate of diagnosis
d	probability of misdiagnosis
c	probability of inefficient treatment
θ	rate of getting ADD by environmental factors
α	rate of getting ADD by misdiagnosis
r	probability of treatment by medication
$1 - r$	probability of treatment by therapy
t	probability of inefficient treatment by medication
q	probability of inefficient treatment by therapy

Table 1: List of Parameters

Next, the matrix of one-step transition probabilities, namely, P , is given by

$$P = \begin{pmatrix} 0 & \frac{\sigma}{\mu + \gamma d + \sigma} & \frac{\gamma d}{\mu + \gamma d + \sigma} & \frac{\mu}{\mu + \gamma d + \sigma} \\ 0 & 0 & \frac{\gamma(1-d)}{\gamma(1-d) + \mu} & \frac{\mu}{\gamma(1-d) + \mu} \\ (1-c) & c & 0 & 0 \\ 1 & 0 & 0 & 0 \end{pmatrix} \quad (7)$$

Now, recall that $\pi^T = (\pi_0, \pi_1, \pi_2, \pi_3)$. We have found the following expression for π by applying 4,

$$\begin{aligned} \pi_0^* &= \frac{((-1+c)(-1+d)\gamma + \mu)\phi}{-d^2\gamma^2 + \gamma\sigma + (\gamma - c\gamma + \mu + \sigma)\phi + d\gamma(\gamma + \mu - \sigma - \phi + 2c\phi)} \\ \pi_1^* &= \frac{(cd\gamma + \sigma)\gamma}{-d^2\gamma^2 + \gamma\sigma + (\gamma - c\gamma + \mu + \sigma)\phi + d\gamma(\gamma + \mu - \sigma - \phi + 2c\phi)} \\ \pi_2^* &= \frac{\gamma(-\sigma + d((-1+d)\gamma - \mu + \sigma))}{-d^2\gamma^2 + \gamma\sigma + (\gamma - c\gamma + \mu + \sigma)\phi + d\gamma(\gamma + \mu - \sigma - \phi + 2c\phi)} \end{aligned}$$

It follows from figure 1 that children leave the state X_0 because either they are misdiagnosed, acquire ADD, or become adult. Recall that γ denotes the rate of receiving treatment and d is the probability of misdiagnosis. Hence the rate at which children in X_0 receive treatment as a consequence of misdiagnosis is given by γd . Also, individuals in X_0 acquire ADD at a rate σ , and become adults at a rate μ . As pointed out before, individuals are arriving to the system through X_0 . This state receives children from state T at a rate $\phi(1-c)$, where c denotes the probability of treatment inefficiency, and ϕ denotes the rate at which individuals leave treatment class to X_0 .

Concerning the state X_1 , children either leave for treatment, or become adults. Children leave for treatment at a rate $\gamma(1-d)$, or become adults at a rate μ . Observe that there is no transition from X_1 to X_0 , since there does not exist a natural recovery from ADD. Since ϕ denotes the rate of leaving treatment and c denotes the probability of treatment inefficiency, children from state T arrive into state X_1 at a rate ϕc .

Now, let us assume that the system input goes from Δ to X_1 . Hence, P is given by,

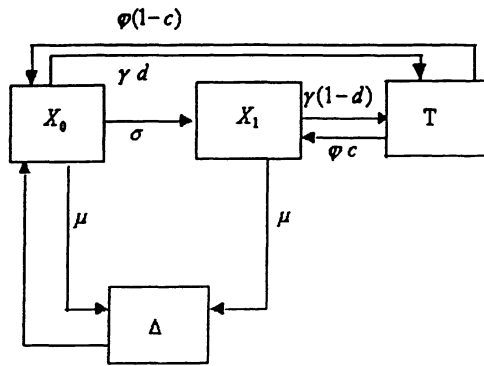

Figure 1: 4-State simulation, input into X_0

$$P = \begin{pmatrix} 0 & \frac{\sigma}{\mu + \gamma d + \sigma} & \frac{\gamma d}{\mu + \gamma d + \sigma} & \frac{\mu}{\mu + \gamma d + \sigma} \\ 0 & 0 & \frac{\gamma(1-d)}{\gamma(1-d) + \mu} & \frac{\mu}{\gamma(1-d) + \mu} \\ \phi(1-c) & \phi c & 0 & 0 \\ 0 & 1 & 0 & 0 \end{pmatrix} \quad (8)$$

We can see in figure 2 the diagram of the 4-state model, for which the rates are the same as in the previous case.

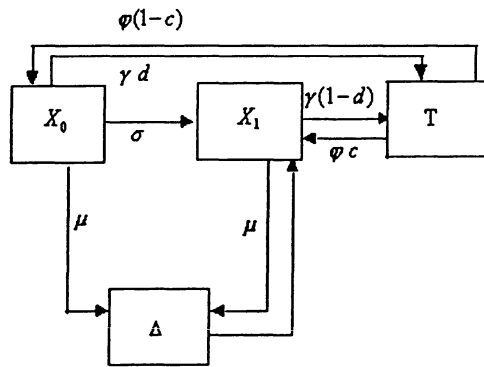

Figure 2: 4-State simulation, input into X_1

Using equation [4], the stationary probability π is given by,

$$\begin{aligned}\pi_0^* &= \frac{(-1+c)(-1+d)\gamma\phi}{-(-1+d)\gamma(d\gamma+\mu+\sigma) + ((1-d+c(-d))\gamma+\mu+\sigma)\phi} \\ \pi_1^* &= \frac{(cd\gamma+\mu+\sigma)\phi}{-(-1+d)\gamma(d\gamma+\mu+\sigma) + ((1-d+c(-1+2d))\gamma+\mu+\sigma)\phi} \\ \pi_2^* &= \frac{(-1+d)\gamma(d\gamma+\mu+\sigma)}{-(-1+d)\gamma(d\gamma+\mu+\sigma) + ((1-d+c(-1+2d))\gamma+\mu+\sigma)\phi}\end{aligned}$$

4.2 3-State Model

The states for this model are: children without ADD, children with ADD, and adult state.

Let X_0 denote the state of children without ADD. Let X_1 be the state of children with ADD. We are letting ϕ to be large enough such that the treatment is instantenous. Recall the the average time spent at state T is given by $\frac{1}{\phi}$.

In this model, the finite-state space Ω , is defined as follows,

$$\Omega = \{X_0, X_1, \Delta\}$$

Let P be given by,

$$P = \begin{pmatrix} 0 & \frac{\sigma+\gamma d}{\sigma+\gamma d+\mu} & \frac{\mu}{\sigma+\gamma d+\mu} \\ \frac{\phi}{\phi+\mu} & 0 & \frac{\mu}{\phi+\mu} \\ 1 & 0 & 0 \end{pmatrix} \quad (9)$$

We have

$$\begin{aligned}\pi_0^* &= \frac{\phi}{\sigma+\gamma d+\phi} \\ \pi_1^* &= \frac{\sigma+\gamma d}{\sigma+\Gamma d+\phi}\end{aligned}$$

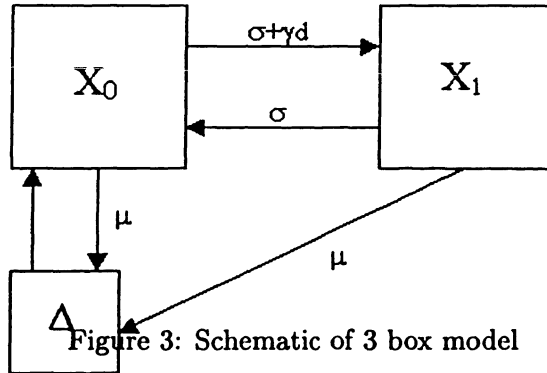

Figure 3: Schematic of 3 box model

4.3 6-State Model

The following states are considered in this model; children without ADD, children with ADD, treatment with medication, treatment with therapy, children with ADD who become functional through treatment, and the adult state.

Let X_0 denote children without ADD, X_1 denote children with ADD, T_M denote treatment through medication, T_T denote treatment through psychiatric therapy, X_2 functional children through treatment, and Δ denote the adult state.

Therefore, Ω is given by,

$$\Omega = \{X_0, X_1, T_m, T_t, X_2, \Delta\}$$

The one-step transition probability matrix P is as follows,

$$P = \begin{pmatrix} 0 & \frac{\theta + \alpha(1-d)}{\mu + \theta + \alpha(1-d)} & 0 & 0 & 0 & \frac{\mu}{\mu + \theta + \alpha(1-d)} \\ 0 & 0 & \frac{\gamma r}{\gamma + \mu} & \frac{\gamma(1-r)}{\gamma + \mu} & 0 & \frac{\mu}{\gamma + \mu} \\ 0 & t & 0 & 0 & (1-t) & 0 \\ 0 & q & 0 & 0 & (1-q) & 0 \\ 0 & 0 & 0 & 0 & 0 & 1 \\ 1 & 0 & 0 & 0 & 0 & 0 \end{pmatrix} \quad (10)$$

4.4 6-State Model

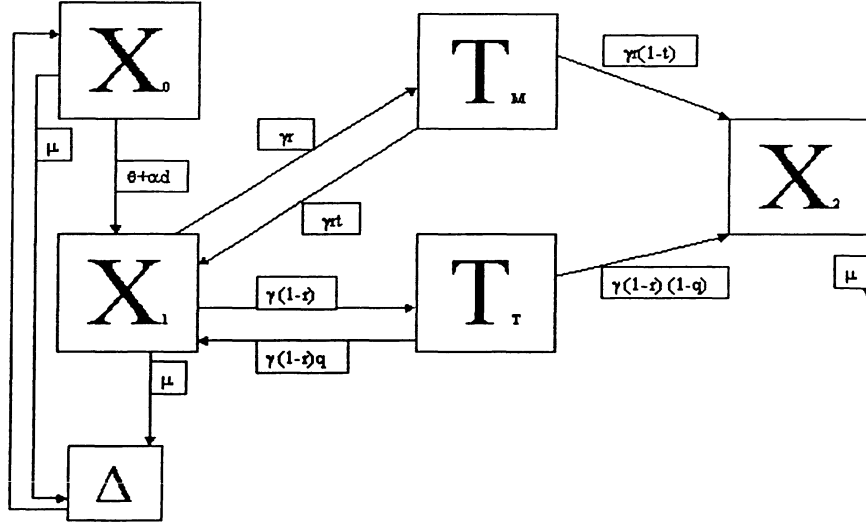

Figure 4: This is the model designed for the possible treatments by entering an individual through X_0 .

In this model we identify each individual more specifically, along with the treatment the individual is given. We have 5 groups of individuals in accordance to the description of the individual at a certain time. The individual in X_0 is a child who is not born with the disorder and do not carry the disorder in their gene description. This child is still capable of getting the disorder; either by environmental factors, or by being wrongfully treated with medication and therapy that makes them behave as a child with the disorder, even though the child does not have it. The individual in

X_1 is a child that has the disorder, and are expressing the symptoms associated with it. This child might go into either type of treatment available, or stay in that state since he did not seek any treatment. The first treatment available for the child that demonstrates the disorder is T_M . This treatment is defined as a child that receives any type of treatment along with being prescribed a drug medication to control their behavior. In this state once the child finishes the treatment s/he might be capable of functioning well in a social environment or if the medication does not work, then s/he goes back to X_1 . As seen on the model, the only way to get out of treatment is by being correctly treated or if the treatment is inefficient. We are assuming that the child does not go into adulthood under any of the compartments defined as treatments. The other type of treatment, T_T , is the treatment in which the child gets only therapy or some type of special education that does not involve any type of medication. This child has the probability of returning to X_1 , meaning that the treatment was inefficient, or go into X_2 by finishing the treatment positively. The next state, X_2 , is the child that has undergone treatment and is defined as clinically being stable to handle normal social situations. We also define this child as one who has the possibility of still taking medication but it is on a constant dose just to keep the disorder under control. This model observes the efficiency of the treatment once the child has the disorder, by defining them into a new state. The treatments are divided in two categories to observe which of the treatments is the most effective.

Based on the model chosen and the probability of going from one group to another once we introduce an individual as one that is not believed to have the disorder genetically, by observing the basic probability flow of the system we can hypothesize that if we introduce a child into X_0 , the probability of finding him is higher in X_0 , than in any other of the states, so the probability of finding an individual in any of the treatment states should be the lowest. If we introduce an individual in the X_1 state, the probability of him going to X_0 is 0, since there is no way of entering that state if you get out of there. Based on the values assigned to each variable once you are in X_1 , the probability of going to any other group is much higher than if you had previously started in X_0 . So in conclusion we hypothesize that even though there should be a high probability of finding the child in X_1 , we say that there will be a higher probability of finding a child in X_2 , in comparison to the previous entry of the model.

These are the equations for the treatment specified model, were the child entered does not have the disorder genetically, and s/he still has probability of moving to any of the other groups.

$$\begin{aligned}\pi_0^* &= \frac{\mu((1+q(-1+r)-rt)\gamma+\mu)}{(1+q(-1+r)-rt)\gamma(\theta+\mu)+\mu(3\theta+\mu)-(-1+d)\alpha((1+q(-1+r)-rt)\gamma+3\mu)} \\ \pi_1^* &= \frac{((-1+d)\alpha-\theta)\mu}{-(1+q(-1+r)-rt)\gamma(\theta+\mu)-\mu(3\theta+\mu)+(-1+d)\alpha((1+q(-1+r)-rt)\gamma+3\mu)} \\ \pi_2^* &= \frac{((1+q(-1+r)-rt)\gamma+((-1+d)\alpha-\theta))\mu}{-(1+q(-1+r)-rt)\gamma(\theta+\mu)+\mu(3\theta+\mu)-(-1+d)\alpha((1+q(-1+r)-rt)\gamma+3\mu)} \\ \pi_3^* &= \frac{((-1+d)\alpha-\theta)\mu}{-(1+q(-1+r)-rt)\gamma(\theta+\mu)+\mu(3\theta+\mu)-(-1+d)\alpha((1+q(-1+r)-rt)\gamma+3\mu)} \\ \pi_4^* &= \frac{((-1+d)\alpha-\theta)\mu}{-(1+q(-1+r)-rt)\gamma(\theta+\mu)+\mu(3\theta+\mu)-(-1+d)\alpha((1+q(-1+r)-rt)\gamma+3\mu)}\end{aligned}$$

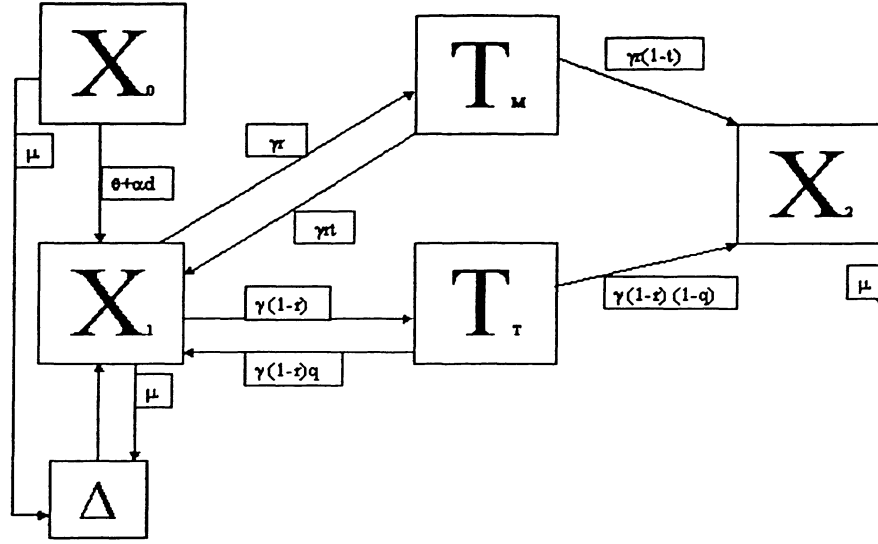

Figure 5: This is the model designed for the possible treatments by entering an individual through X_1 .

These are the equations for the case where the child enters having the disorder genetically:

$$\pi_0^* = 0$$

$$\pi_1^* = \frac{\mu}{(1 + q(-1 + r) - rt)\gamma + 3\mu}$$

$$\pi_2^* = \frac{(1 + q(-1 + r) - rt)\gamma}{(1 + q(-1 + r) - rt)\gamma + 3\mu}$$

$$\pi_3^* = \frac{\mu}{(1 + q(-1 + r) - rt)\gamma + 3\mu}$$

$$\pi_4^* = \frac{\mu}{(1 + q(-1 + r) - rt)\gamma + 3\mu}$$

5 Analysis and Numerical Results

Rates

In order to construct the model we had to rely on previous studies, and collect all information necessary to understand the definitions of the parameters and the meaning of the values assigned to each of them. We will justify as much as possible why the parameters were given the values specified.

Parameter μ , gives the rate at which a child becomes an adult. Since we want to model this from the beginning stages of the disorder, we start at age 3 and go until age 18, $\mu = \frac{1}{15}$.

σ is the rate at which a child gets the disorder genetically. It is known that 1 out of 30 children have the disorder on average, and around 70% of the cases are due to heredity, so we estimate 1 every 12 years a child might get the disorder genetically, $\sigma = \frac{1}{12}$. γ is the rate at which a child gets diagnosed with the disorder per year. We assume a range of possible outcomes, and we

chose it to be a value between $\frac{1}{7}$ and $\frac{1}{14}$ a child gets diagnosed with the disorder every year, since there exist different probabilities of diagnosis. ϕ is the rate at which children leave the treatment. This definition is rather broad, since by finishing treatment we mean, that they have been given a specified dose of medication that would control their behavior in such a way that they can function at a normal level in society. Although not all individuals need to have this dosage throughout their lifetime, we also need to define this rate. From previous studies done, researchers have said that around 50 – 65% of children take their disorder into adulthood, and that around 70% of the time the treatment is efficient, so this rate depends on the rate defined to γ , and this would be 60% of the value of $\gamma = \frac{1}{12}$ to $\frac{1}{24}$.

θ is the rate at which a child could get the disorder by other components other than genetically, these were defined in our introduction to be environmental factors, such as lead poisoning, home behavior etc. It has been found that around 15% of the individuals can acquire the disorder due to this type of exposure for which we approximate this rate as being $\frac{1}{12}$. Every year a child is prone to be exposed to these affecting factors.

Probabilities

On the 2-box model d is the probability of being diagnosed with the disorder. This value is different for the other boxes and ranges from 50-75% to study the optimized value for the model.

On the 3-box model we have defined d to be the probability of being incorrectly diagnosed with the disorder. On average around 5-15% of children might be misdiagnosed with the disorder. In this case we would like to study the cases when the misdiagnosis is from 0 to 100%.

On the 5-box model we have assigned d as the probability of getting add by genetic factors.

c - is the probability of an inefficient treatment. Observational studies have found a 30% probability of treatment failure. In simulations performed c ranges from 0 to 100%.

r - defined as the probability of treatment by medication. And is sent to treatment, then this person has certain probability of getting either of the two types of treatments, being treated with medication, and being treated with therapy, $(1-r)$. We want to send more individuals to r , since from data collected, a high proportion of individuals treated, are treated by medication, around 80% of children treated are with medication.

t - defined as the probability of inefficient treatment if s/he is prescribed medication. Research studies have found that around 30% of the time medication is inefficient.

q - defined as the probability of inefficient treatment by therapy. The research done did not give us any exact percentage of individuals that finish this type of treatment inefficiently but we chose it to be around 45%, since there has been a decrease in using only this type of prescription. Since we want to vary this value, we chose the fixed value whenever we wanted to vary the probability value of t .

5.1 4-State Model

Let $i \in \{0, 1, 2\}$.

Our simulations are graphs of $\pi_i^* = \pi_i^*(c)$, fixing d with values $\{0.01, 0.05, 0.1, 0.2, 0.35\}$. We also graph $\frac{\pi_0^*}{\pi_1^*}$ as a function of c .

The simulations were performed for both cases: system input in X_0 as well as system input in X_1 .

It is observed that, $\frac{\pi_0^*}{\pi_1^*}$, i.e., that the ratio of children without ADD to children with it, decays as the treatment becomes more inefficient.

It is also observed that for fairly efficient treatment, more children are conglomerated in the state X_0 than in X_1 , this is, for values of c near to zero. Whereas, for treatment nearly inefficient,

more individuals seem to be merge into X_1 than in X_0 . Despite this behaviour the ratio $\frac{\pi_0^*}{\pi_1^*}$ decays smoothly to zero as c tends to one.

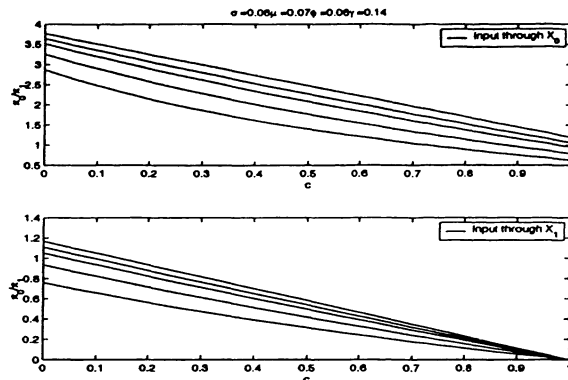

Figure 6: $\frac{\pi_0^*}{\pi_1^*}$ as a function of inefficiency c

In Figure ?? we see how the ratio $\frac{\pi_0^*}{\pi_1^*}$ decays faster for higher values of d , this is, for high probability of misdiagnosis. Using the data generated for the simulations shown in Figure??, we performed a regression analysis. Through this analysis, we observed that for nearly-zero values of probability of misdiagnosis there exists a linear relationship between $\frac{\pi_0^*}{\pi_1^*}$ and c , the probability of treatment inefficiency. Whereas that for values of d close to 0.35, there exists a quadratic relationship between $\frac{\pi_0^*}{\pi_1^*}$ and c .

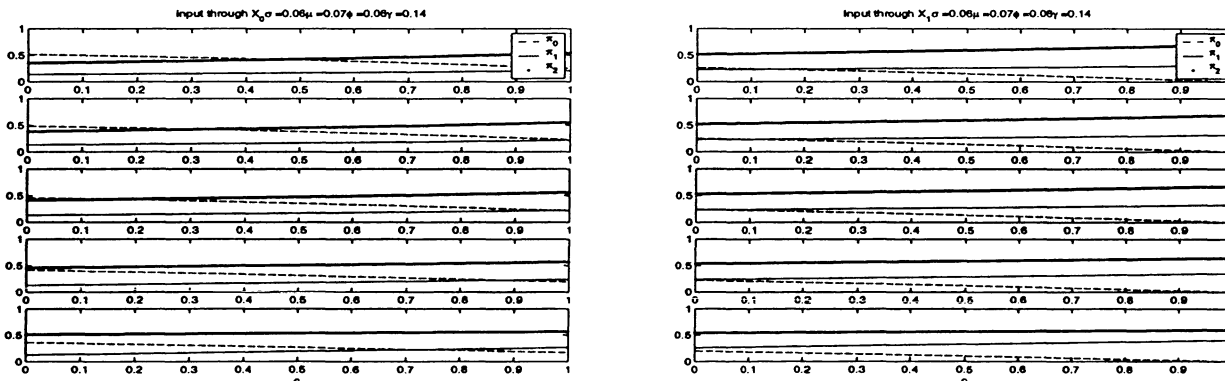

Figure 7: Stationary distributions with input through X_0 and X_1 .

In Figure ?? we see how the ratio $\frac{\pi_0^*}{\pi_1^*}$ decays faster for higher values of d , this is, for high probability of misdiagnosis. Using the data generated for the simulations shown in Figure??, we performed a regression analysis. Through this analysis, we observed that for nearly-zero values of probability of misdiagnosis there exists a linear relationship between $\frac{\pi_0^*}{\pi_1^*}$ and c , the probability of treatment inefficiency. Whereas that for values of d close to 0.35, there exists a quadratic relationship between $\frac{\pi_0^*}{\pi_1^*}$ and c .

5.2 3-State Model

Several simulations were made of the model varying the probability of misdiagnosis to see what is the stationary probability that an individual is at a certain class as a function of ϕ , the rate of leaving the treatment.

Figure ?? shows the result of a simulation when the misdiagnosis probability is .1. For small values of ϕ , which means that the recovery time is very long, it is shown that there are more people with ADD than in the functional class. As ϕ increases, individuals are being cured at a faster rate, so the probability of the individual to be in the functional class increases.

Another simulation is made increasing the probability of misdiagnosis to .35.

It is seen in Figure ?? how an increase in the rate of misdiagnosis causes the point at which both groups are equal to be at a higher value of ϕ . This is because more people are being misdiagnosed and they go to the ADD class so it takes a faster treatment for the people to leave the class. It is also evident that for high values of ϕ , the stationary probability of being in the ADD class is higher than the case when the probability of misdiagnosis is lower.

5.3 6-State Model

In the simulations we hoped to observe what happened when the probability of entering into treatment and the probability of making one of the treatments is increased.

In our graphs we will plot on π_i vs. r and q , since the graphs with varying t are the same except it decreases in the other extreme value of r . A few of those graphs are plotted in the appendix. From the different π_i we will look at the graphs that will give us the information we are looking for.

As we can see in ?? as we increase r and q , the change in probability is not that significant to the complete change of extremes, since the probability of exiting this group does not involve r and t .

On ??, the plot gives us very important information, as we decrease the value of r , this means that we will be sending at a higher rate the child to T_T , and by increasing q , we are sending the child back to X_1 , this meaning that the treatment with therapy is ineffective.

As seen in this graph as we decrease r and increase q , we see that the value of π_2 decrease since everybody that has been treated returns to demonstrating the symptoms of ADD, and so forth s/he will not be able to be treated efficiently. The graphs of π_3, π_4 are both increase as r goes to 0 and q goes to 1. The interesting output is when a child that is known that has the disorder due to genetic heritability is introduced in the model through X_1 , the movement to T_M and T_T shows us how we would expect the probability to change as we change the values of q .

6 Regression Analysis

Based on the simulations we built for our models, we are able to plot a regression line on Minitab, and this gives us a regression equation for determining the ratio of being in π_0 to π_1 . The importance of this equation is that we found that as we get a complicated model we would need a higher degree polynomial to fit the regression in order to give a better estimate. For our model of having the disorder at 35% inefficiency we had to fit a quadratic curve in order to get a good estimate of our ratio. Once we have determined our correct parameter values for each flow in and out of a class, we can make a regression equation, that would let us estimate the ratio of being in any given class, by just knowing the efficiency of the treatment given to the patient.

7 Concluding Remarks

Using an irreducible ergodic Markov chain, we have computed the stationary proportion of children in each state of our model. We were able to optimize the ratio of proportion of children without ADD to children with it, by adjusting the treatment inefficiency and improving the diagnostic tools. A regression analysis can be used to estimate the ratio of proportion of children without ADD to children with it, given the treatment inefficiency. Within a confidence interval the ratio of proportion mentioned previously, behaves as a quadratic function of the probability of treatment inefficiency. We conclude that the ratio of proportion of children without ADD to children with it, can be used as a measure of the population treatment effectiveness. This is, by studying how this ratio of proportion varies as a function of the treatment inefficiency and misdiagnosis, the effect of the treatment at a population level can be measured.

8 Future Work

We consider appropriate to propose and analyze a regression model of the guidelines used to diagnose ADD. An age-structured like model can be proposed to study the effectiveness of treatment for ADD. The stochastic approach applied in the models studied in this project can be extended to model more realistic instances. Moreover, this methodology may be applied to build up models in order to study other disorders. We recommend to complement the results obtained with a precise study employing ADD observed data. We also propose to create a cost sensitivity analysis of our model, in order to determine which is better, to vary, treatment efficacy or diagnosis in order to improve recovery.

References

- [1] Arnsten, A.(2000). Genetics of Childhood Disorders: XVII. ADHD, Part 2: Norepinephrine has a Critical Modulatory Influence on Prefrontal Cortical Function. *Journal of the American Academy of Child & Adolescent Psychiatry* **39**, 1201-1203.
- [2] Barkley, R.(2000). Genetics of Childhood Disorders: XVII. ADHD, Part 1: The Executive Functions and ADHD. *Journal of the American Academy of Child & Adolescent Psychiatry* **39**, 1064-1068.
- [3] Barkley, R. (1997). *ADHD and the Nature of Self-Control*. Guilford Press.
- [4] Biederman, J., and Spencer, T.(2000). Genetics of Childhood Disorders: XIX ADHD, Part 3: Is ADHD a Noradrenergic Disorder? *Journal of the American Academy of Child & Adolescent Psychiatry* **39**, 1330-1333.
- [5] Bussing, R., Zima, B., and Perwien, A.(2000). Self-Esteem in Special Education Children with ADHD: Relationship to Disorder Characteristics and Medication Use. *Journal of the American Academy of Child & Adolescent Psychiatry* **39**, 1260-1269.
- [6] Connor, D.(2002). Preschool Attention Deficit Hyperactivity Disorder: A Review of Prevalence, Diagnosis, Neurobiology, and Stimulant Treatment. *Journal of Developmental and Behavioral Pediatrics* **23**, s1-s2.

- [7] Faraone, S.(2000). Genetics of Childhood Disorders: XX. ADHD, Part 4: Is ADHD Genetically Heteogeneous? *Journal of the American Academy of Child & Adolescent Psychiatry* **39**, 1455-1457.
- [8] Faraone, S., Biederman, J. and Friedman, D.(2000). Validity of DSM-IV Subtypes of Attention-Deficit/ Hyperactivity Disorder: A Family Study Perspective. *Journal of the American Academy of Child & Adolescent Psychiatry* **39**, 300-307.
- [9] Fisher, B. and Beckley, R.(1999). *Attention Deficit Disorder: Practical Coping Methods*. CRC Press.
- [10] Golub, G., and Van Loan, C.(1996). *Matrix Computations*. Third Edition. Johns Hopkins Universtity Press. Baltimore, Maryland.
- [11] Hernández-Suárez, C.(2002). A Markov Chain Approach to Calculate R_0 in Stochastic Epidemic Models. *Journal of Theoretical Biology* **215**, 83-93.
- [12] Hoagwood, K., Kelleher, K., Feil, M., and Comer, D.(2000). Treatment Services for Children with ADHD: A National Perspective. *Journal of the American Academy of Child & Adolescent Psychiatry* **39**, 198-206.
- [13] Ingersoll, B.(1998). *Daredevils and Daydreams: New Perspectives on Attention-Deficit/Hyperactivity Disorder*. Main Street.
- [14] Jordan, D.(1998). *Attention Deficit Disorder-ADHD and ADD Syndromes*. Pro-Ed.
- [15] Mitsis,E.,McKay,K.,Schulz, K.,Newcorn, J., and Halperin, J.(2000). Parent-Teacher Concordance for DSM-IV Attention-Deficit/ Hyperactivity Disorder in a Clinic-Referred Sample *Journal of the American Academy of Child & Adolescent Psychiatry* **39**, 308-313.
- [16] Pliszka, Steven R. M.D., Greenhill, Lawrence L. M.D., et al.(2000). The Texas Children's Medication Algorithm Project: Report of the Texas Consensus Conference Panel on Medication Treatment of Childhood Attention-Deficit/Hyperactivity Disorder. Part I. *Journal of the American Academy of Child & Adolescent Psychiatry* **39**, 908-919.
- [17] Pliszka, Steven R. M.D., Greenhill, Lawrence L. M.D., et al.(2000). The Texas Children's Medication Algorithm Project: Report of the Texas Consensus Conference Panel on Medication Treatment of Childhood Attention-Deficit/Hyperactivity Disorder. Part II:Tactics. *Journal of the American Academy of Child & Adolescent Psychiatry* **39**, 920-927.
- [18] Smalley, S., McGough, J., Del'Homme, M., NewDelman, J., Gordon, E., Kim, T., Liu, A., and McCracken, J.(2000). Familial Clustering of Symptoms and Disruptive Behaviours in Multiplex Families with Attention-Deficit/Hyperactivity Disorder. *Journal of the American Academy of Child & Adolescent Psychiatry* **39**, 1135-1143.
- [19] Sprich, S., Biederman, J., Crawford, M., Mundy, E., and Faraone, S.(2000). Adoptive and Biological Families of Children and Adolescents with ADHD. *Journal of the American Academy of Child & Adolescent Psychiatry* **39**, 1432-1437.
- [20] Thapar, A., Psych, M., Harrington, R., Psych, F., Ross, K., Psych, M., McGuffin, P., and Psych, F.(2000). Does the Definition of ADHD Affect Heritability? *Journal of the American Academy of Child & Adolescent Psychiatry* **39**, 1528-1536.

- [21] Todd, R.(2000). Genetics of Childhood Disorders: XXI. ADHD, Part 5: A Behavioral Genetic Perspective. *Journal of the American Academy of Child & Adolescent Psychiatry* **39**, 1571-1573.

9 Acknowledgements

This research has been partially supported by grants given by the National Science Foundation, National Security Agency, and the Sloan Foundation (through the Cornell-Sloan National Pipeline Program in the Mathematical Sciences). Substantial financial and moral support was also provided by the Office of the Provost of Cornell University, the College of Agriculture & Life Science (CALs), and the Department of Biological Statistics & Computational Biology. The authors are solely responsible for the views and opinions expressed in this research; it does not necessarily reflect the ideas and/or opinions of the funding agencies and/or Cornell University. Also thanks to Carlos M. Hernandez-Suarez for his patience, Sophonie Nshinyabakobeje for his regression, Carlos Castillo-Chavez for his understanding, and our fellow MTBI children for which we will be ever so thankful.

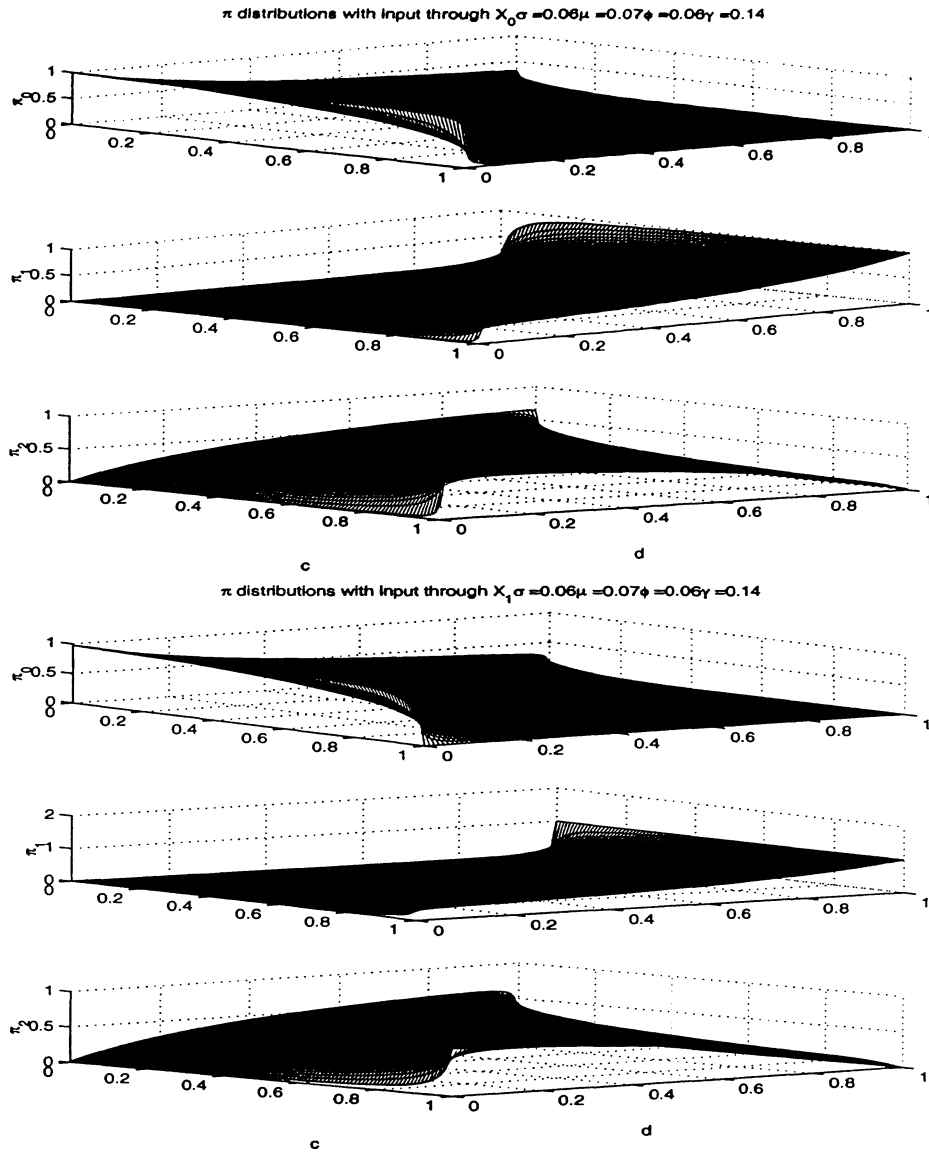
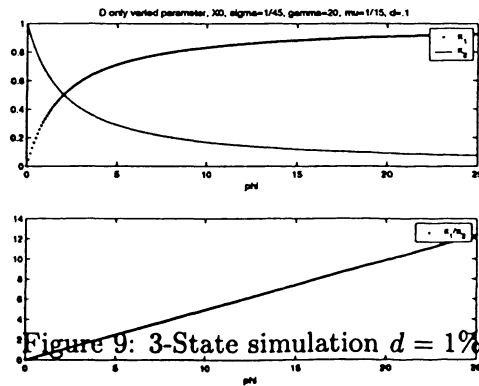

Figure 8: π as a function of (c,d) with input through X_0 and X_1 .



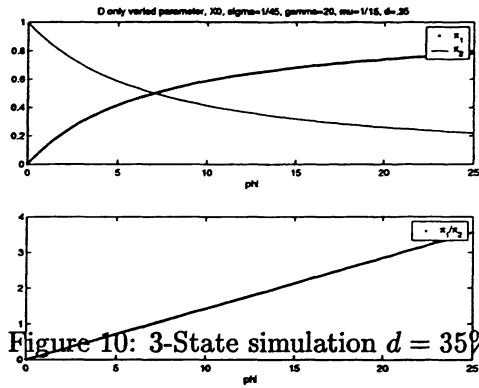

Figure 10: 3-State simulation $d = 35\%$

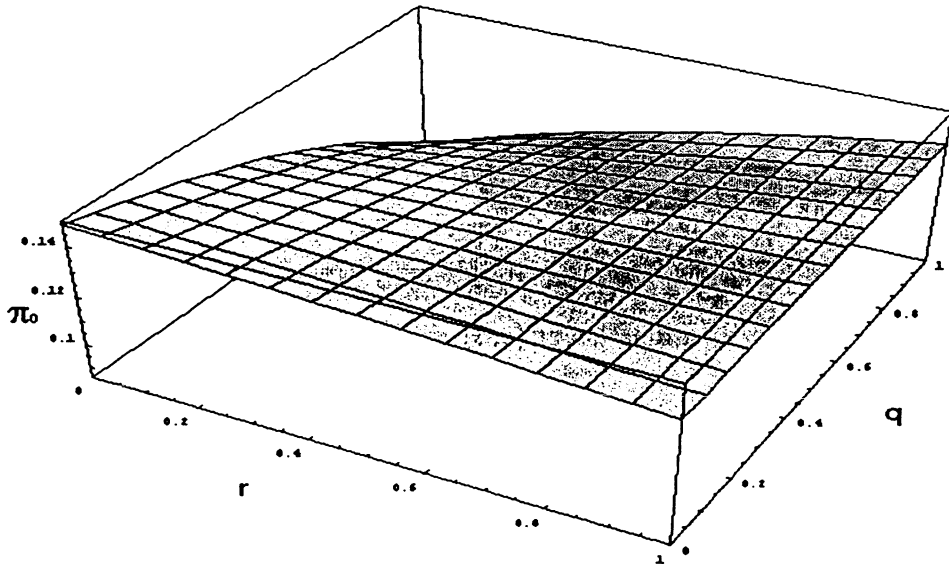

Figure 11: This is the probability plot of π_0 when we vary r and q .

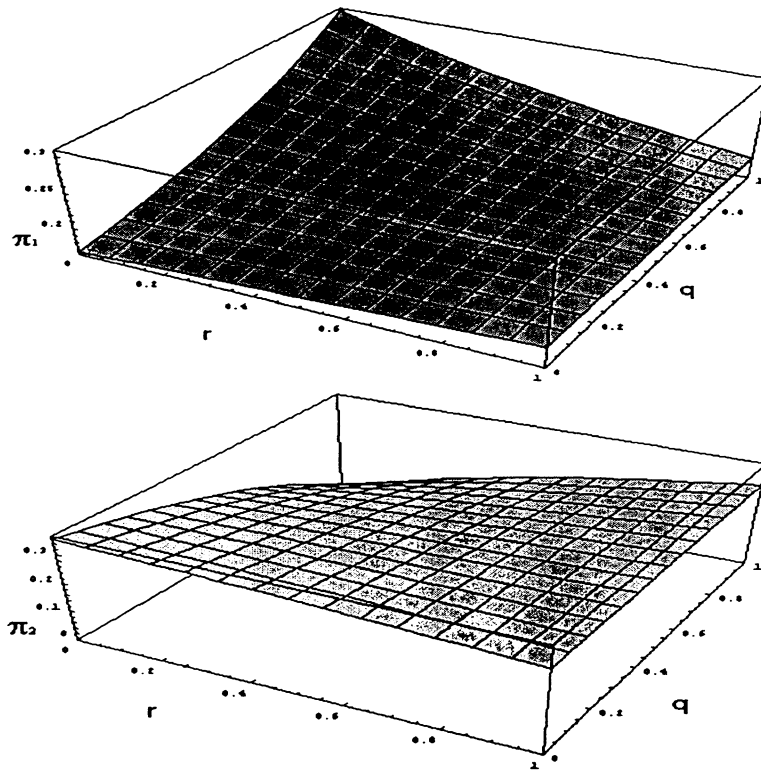

Figure 12: This is the probability plot of π_1 and π_2 when we vary r and q , and the child enters through X_0 .

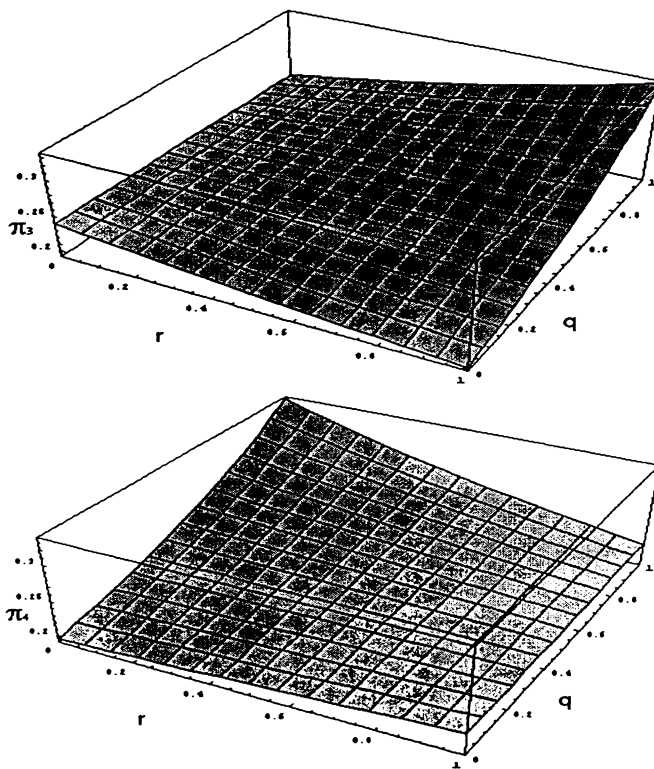

Figure 13: This is the probability plot of π_3 and π_4 when we vary r and q and the child enters through X_1 .

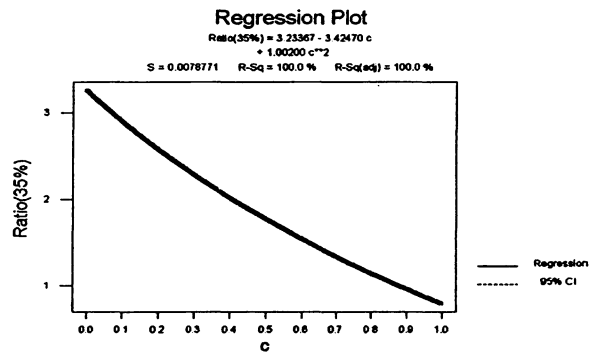
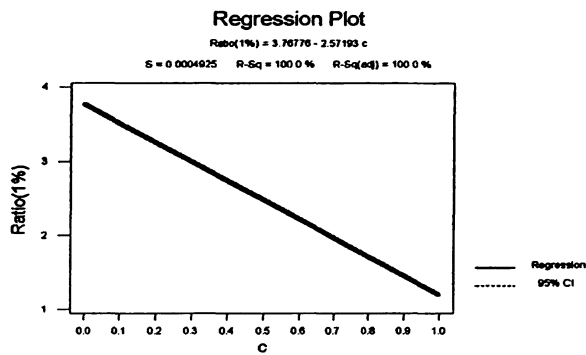

Figure 14: This is the regression lines done to predict the ratio of π_0 to π_1 based on the treatment efficiency.