

**THE EFFECTS OF CONDOM DISTRIBUTION WITH EDUCATION ON CHLAMYDIA
RATES IN HIGH SCHOOLS**

BU- 1507-M

Summer 1998

**Cristina Garcia
Sharon K. Lima
Roberto Munoz-Alicea
and
Catalina Saenz**

Keywords: not provided.

Abstract:

In 1996, the Center for Disease Control reported that adolescents account for the largest proportion of *Chlamydia* cases. One method discussed by experts to control *Chlamydia* rates is education and condom distribution in high schools. This report analyzes a stochastic process and deterministic models to determine the effectiveness of condom distribution with education, in controlling the transmission of *Chlamydia* amongst high school students..

BU 1507-M

The Effects of Condom Distribution with Education on Chlamydia Rates in High Schools

Cristina Garcia *, Sharon K. Lima †, Roberto Munoz-Alicea ‡,
Catalina Saenz §

Abstract

In 1996 the Center for Disease Control reported that adolescents account for the largest proportion of Chlamydia cases. One method discussed by experts to control Chlamydia rates is education and condom distribution in high schools. This report analyzes a stochastic process and deterministic models to determine the effectiveness of condom distribution with education, in controlling the transmission of Chlamydia amongst high school students.

1 INTRODUCTION

Sexual activity among high school students is on the rise and the average age to have sex has decreased to 14.8 years old. The 1995 Youth Risk Behavior Surveillance System (YRBSS) reported that juniors in high school (58.6%) were more likely to have had sex than freshman (36.9%) and sophomores (48.0%). Furthermore, 17% of high school students report having four or more sexual partners (YRBSS, 1995). Although 53.1% of high school students are sexually active, only 54.4% report using a condom during the last time they had sexual intercourse (CDC). This implies that many adolescents are inconsistent in the use of condoms to prevent the spread of sexually transmitted diseases (STD). Some factors that account for this inconsistency are the lack of sex education and the availability of condoms to students.

*Pomona College, Claremont, CA 91711, e-mail: crgarcia@pomona.edu

†University of Iowa, Iowa City, IA 52240, e-mail: skl6@cornell.edu

‡University of Puerto Rico, Humacao, PR 00791, e-mail: rober5677@cuhac.upr.clu.edu

§Wellesley College, Wellesley, MA 02181, e-mail: csaenz@wellesley.edu

Understanding the sexual behavior of high school students is important because teenagers have one of the highest STD transmission rates (Moore, Rosenthal, Mitchell, 1996). Moreover, condom effectiveness for high school students is only 75%, in contrast to 88% for the general population. This implies that not only condom use, but education on how to properly use a condom is necessary.

One of the most prevalent STD's amongst adolescents is Chlamydia. Chlamydia infections are caused by a microorganism called Chlamydia Trachomatis. It is transmitted by contact with genitalia, mouth, or rectum. This infection cannot be transmitted by casual contact such as toilets, saunas, or pools. (Healthy Devil On-line)

Students who are 15 to 19 year old have the highest rates of contracting Chlamydia (Moore, Rosenthal, Mitchell, 1996). Two thirds of women and one third of men with infected partners become infected themselves (Moore, Rosenthal, Mitchell, 1996). From the female cases, 15-19 year olds represent 46% of all Chlamydia cases and 20-24 year olds represent an additional 33% of all cases.

Adolescent women, have an increased chance for infection due to cervical ectopy and lack of immunity (CDC). Common symptoms among women are vaginal discharge and pain when urinating, while men tend to have a ureteral discharge. If it is diagnosed in its early stage, Chlamydia can be easily treated with a 7 day oral antibiotic treatment. Amongst teenagers early treatment is not readily sought because 75% of females and 50% of males are asymptomatic; then the probability of seeking treatment among men is higher than with women (CDC). If left untreated, the CDC reports that 40% of women can develop pelvic inflammatory disease (PID). PID is a significant cause of fertility problems in men and women, ectopic pregnancy and chronic pelvic pain (Moore, Rosenthal, Mitchell, 1996).

One method to control Chlamydia transmission rates is to provide sex education and have condoms readily available in schools. Some school districts believe that until high school students learn how to use a condom properly or have them readily available will the infection rates decrease.

We develop deterministic models and a stochastic process to see the role sex education plays on the transmission dynamics of Chlamydia in a high school. The models take into account the role of the availability of condoms to students and the probability of condom success against Chlamydia. The focus of the deterministic models is to control the Chlamydia transmission with the implementation of education in school, not necessarily to reduce the sexual activity rate of the students. However, for the stochastic process

we consider the relationship between the availability of condoms and the increase of sexual activity among teenagers. In summary, this article will use stochastic and deterministic methods to see if the availability of condoms in high schools will a) make Chlamydia rates decrease, b) will lead to the eradication of Chlamydia amongst high school students, and c) is education on how to properly use a condom, needed to maximize the positive effects of condom distribution?

2 MODELS

2.1 MODEL I

In order to understand the dynamics of Chlamydia transmission amongst high school students, we begin the analysis with a basic epidemiology model. The system models 9th through 12th graders, ages 13 to 19 years old. Students enter the system when they finish eighth grade at a rate (λ), and leave the system when they graduate, drop out, or turn 19, at a rate (μ). Furthermore, it is assumed that all students enter the system uneducated.

We are particularly interested on the effects of condom distribution and education to Chlamydia rates in high schools. The practice of condom distribution and education vary greatly from high school to high school. In order to arrive at a uniform conclusion, we only look at the particular case where condoms are available to all students and they only get them at school. Moreover, a student is educated if and only if the student always uses a condom when engaging in sexual intercourse. Education fails if a student does not use a condom all the time, which is equivalent to receiving no education.

We further assume that a condom is 100% successful against Chlamydia. If a person is educated, then the condom is used effectively. This implies that education has a 100% success rate. It follows from these assumptions that the susceptible educated class has no effect on the system, thus the proportion of educated students enter the recovered class (R_m and R_f , for males and females respectively). The remainder of the students are divided into two categories. The infected students (I_m and I_f , for males and females respectively) and the susceptible uneducated class (S_m and S_f , for males and females respectively), which consist of both abstinent and sexually active adolescents. In addition, we consider a constant male and female student population, where f denotes the total female population and m denotes the total male population. Let N represent the total high school population, $N = f + m$, where $f = S_f + I_f + R_f$ and $m = S_m + I_m + R_m$. Furthermore, the

population is half male and half female. In order to maintain this constant population, the per capita birth rate (λ) and death rate (μ) are equal each other. The preceding assumption comes from the fact each year approximately one fourth of the population leaves the system when a senior class graduates and one fourth enters with a freshman class. Therefore, the total population is constant if and only if $\lambda = \mu$.

The following compartment model depicts the interaction between the different classes.

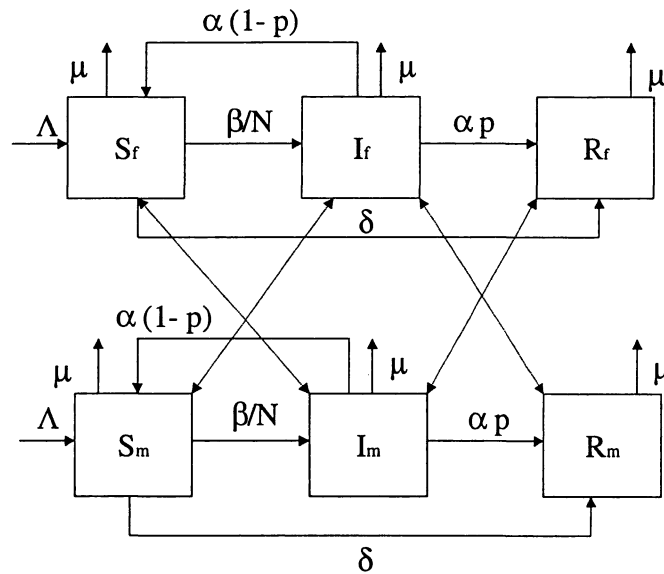

2.1.1 PARAMETERS AND VARIABLES FOR MODEL I

Let

α = recovery rate of infection

β = successful transmission rate

δ = proportion of susceptible class that is educated

μ = death rate

λ = birth rate

p = probability that an infected individual becomes educated

Define

S_m as the susceptible male population that is uneducated

I_m as the infected male population

R_m as the educated male population that has been previously infected or not at all

S_f as the susceptible female population that is uneducated

I_f as the infected female population

R_f as the educated female population that has been previously infected or not at all

2.1.2 DESCRIPTION OF MODEL I

A total of $\lambda \frac{N}{2}$ females from the eighth grade enter the susceptible class (S_f), where λ is the per capita birth rate into high school. One portion of the susceptible population is leaving at a rate (δ) and entering the educated class. A susceptible female moves to the infected class by coming in contact with an infected male ($\frac{S_f I_m}{N}$) with a successful transmission rate (β). The successful transmission rate is the probability of passing the infection multiplied by the sexual contact rate. Once in the infected female class they can get treated, α denotes the recovery rate from the infection and $\frac{1}{\alpha}$ is the life span of the disease. Let p be the probability that an infected individual gets educated, thus $(1-p)$ is the probability that an infected individual does not get educated. At which point, a proportion of them $(1-p)$ will not use condoms regularly, thus they re-enter the susceptible class. The proportion that enter the recovered class will change their habits and use condoms every time they have sex ($p\alpha$). In all three components (S_f , I_f , R_f), the females leave the system at a rate μ which is the per capita death rate of the female students by graduating or dropping out from high school or turning 19 years old.

The interaction for males is symmetric to females. This model assumes that students are only having heterosexual intercourse with other high school students. In addition, the recovery rate (α) and the transmission rate (β), are the same for males and females. All students have the same probability to become infected and recovered. The model also includes heterogeneous random mixing, for example, it is equally likely for a non-sexually active student to engage in sex as a sexually active student.

The equations are:

Males:

$$\frac{dS_m}{dt} = N \frac{\lambda}{2} - \frac{\beta S_m I_f}{N} - (\mu + \delta) S_m + \alpha(1-p)I_m$$

$$\frac{dI_m}{dt} = \frac{\beta S_m I_f}{N} - (\alpha + \mu) I_m$$

$$\frac{dR_m}{dt} = \delta S_m + \alpha p I_m - \mu R_m$$

Females:

$$\begin{aligned}\frac{dS_f}{dt} &= N\frac{\lambda}{2} - \frac{\beta S_f I_m}{N} - (\mu + \delta) S_f + \alpha(1-p)I_f \\ \frac{dI_f}{dt} &= \frac{\beta S_f I_m}{N} - (\alpha + \mu) I_f \\ \frac{dR_f}{dt} &= \delta S_f + \alpha p I_f - \mu R_f\end{aligned}$$

The following dynamics of the system follow from the assumptions.

If $p = 0$, no ineffective individuals are being educated. The model is SIS.

If $p = 1$, all infected individuals are being educated. The infected class will eventually turn into a recovered class. Thus, as time goes to infinity, the disease will die out of the system.

Notice that the infected class can move into two distinct compartments either susceptible class or recovered i.e. $\alpha I = \alpha(1-p) I + \alpha(p)I$.

2.2 MODEL II

Model I and Model II share most of the same parameter and assumptions. Model II is an extension and modification of the ideas incorporated in Model I. Instead of an S-I-R model, we have an S-I-S model. The probability of natural condom success is no longer 100%, thus our educated class affect the system's dynamics. Condoms have a 75% probability of success among teenagers. Furthermore, this model eliminates the assumption that both males and females have the same recovery rate (α_f and α_m , for females and males respectively) and the same transmission rate (β_f and β_m , for females and males respectively). As previously mentioned, statistics show that men and females have different contact rates and different recovery periods.

This is the compartment diagram for Model II:

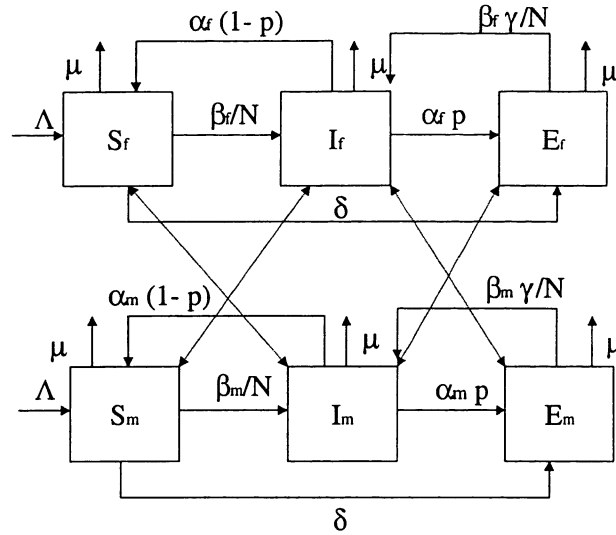

2.2.1 PARAMETERS AND VARIABLES OF MODEL II

Let

- α_f = recovery rate of infection for females
- α_m = recovery rate of infection for males
- β_f = successful transmission rate for females
- β_m = successful transmission rate for males
- γ = probability of condom failure for adolescents
- δ = proportion of susceptible class that is educated
- μ = death rate
- λ = birth rate
- p = probability that an infected individual becomes educated

Define

- S_m as the susceptible male population that is uneducated
- I_m as the infected male population which may be educated or not
- E_m as the educated male population that has been previously infected

or not at all

- S_f as the susceptible female population that is uneducated
- I_f as the infected female population which may be educated or not

E_f as the educated female population that has been previously infected or not at all

2.2.2 DESCRIPTION OF MODEL II

Similar to Model I, let m represent the male population of high school students and f be the female students. Let S_m denote the susceptible class of male students who are not educated and E_m is the susceptible males who are educated. Let δ represent the proportion of students who are educated and always use a condom. These variables are symmetrical for both the male and female population.

Unlike Model 1, the educated class can move into the infected class. The assumption of 100% condom effectiveness is dropped which implies that some educated students become infected by the probability of that the condom fails (γ). In Model II we assume the successful transmission rate (β) is the same between an educated and infected couple as a susceptible and infected one. We define an educated person as a student who always uses a condom. It then follows from the definition that the probability of infection between educated and infected will be smaller than a susceptible and infected. We multiply by the probability of condom failure (γ) to term $\frac{\beta_f E_f I_m}{N}$ to achieve the desired inequality. Thus education no longer implies complete immunity. If you let $\gamma = 1$, then the probability of condom failure is 100%. This is equivalent to not being educated or an infected coming into contact with a susceptible ($\frac{\beta_m S_m I_f}{N}$)

The equations are

Males:

$$\begin{aligned}\frac{dS_m}{dt} &= N\frac{\lambda}{2} - \frac{\beta_m S_m I_f}{N} - (\mu + \delta)S_m + \alpha_m(1 - p)I_m \\ \frac{dI_m}{dt} &= \frac{\beta_m S_m I_f}{N} - (\alpha_m + \mu)I_m + \frac{\gamma\beta_f E_m I_f}{N} \\ \frac{dE_m}{dt} &= \delta S_m + \alpha_m p I_m - \mu E_m - \frac{\gamma\beta_f E_m I_f}{N}\end{aligned}$$

Females:

$$\begin{aligned}\frac{dS_f}{dt} &= N\frac{\lambda}{2} - \frac{\beta_f S_f I_m}{N} - (\mu + \delta)S_f + \alpha_f(1 - p)I_f \\ \frac{dI_f}{dt} &= \frac{\beta_f S_f I_m}{N} - (\alpha_f + \mu)I_f + \frac{\gamma\beta_f E_f I_m}{N} \\ \frac{dE_f}{dt} &= \delta S_f + \alpha_f p I_f - \mu E_f - \frac{\gamma\beta_f E_f I_m}{N}\end{aligned}$$

Notice also in this system, the infected class have influx from both educated and susceptible classes.

3 DETERMINISTIC MODELS

3.1 MODEL I

We begin the analysis by looking at Model I. Since all the parameters (i.e., rates and probabilities) are the same for males and females, the males and female populations have the same dynamics. Therefore we expect that as $t \rightarrow \infty$ the number of susceptible, infected and recovered individuals will be the same. Figure 1 in the appendix shows that when we start with different initial conditions for males and females, the population will show the same behavior for males and females. Hence, it is sufficient to study a one sex model equivalent to the following three equations:

$$\begin{aligned}\frac{dS}{dt} &= N\lambda - \frac{\beta SI}{N} - \delta S + \alpha(1-p)I - \mu S \\ \frac{dI}{dt} &= \frac{\beta SI}{N} - \alpha I - \mu I \\ \frac{dR}{dt} &= \delta S + \alpha p I - \mu R\end{aligned}$$

Since we assume that $\lambda = \mu$, then we have a constant population. Therefore we have $\frac{dN}{dt} = \frac{dS}{dt} + \frac{dI}{dt} + \frac{dR}{dt} = 0$. Thus by Thiemes Theorem it is sufficient to only work with the first two equations.

To study the equilibrium we linearize our system of equations. Thus, the general Jacobean is:

$$Jacobian = \begin{pmatrix} -(\delta + \frac{\beta I}{N} + \mu) & \alpha(1-p) - \frac{\beta S}{N} \\ \frac{\beta I}{N} & -(\alpha + \mu) + \frac{\beta S}{N} \end{pmatrix}$$

We look at the disease free state points $(S, I, R) = (\frac{\mu N}{\delta + \mu}, 0, \frac{\delta N}{\delta + \mu}) = E_0$ to determine its stability.

The Jacobean at the disease free equilibrium is:

$$J(E_0) = \begin{pmatrix} -(\delta + \mu) & \alpha(1-p) - \frac{\beta \mu}{\delta + \mu} \\ 0 & -\alpha(1-\mu) - \frac{\beta \mu}{\delta + \mu} \end{pmatrix}$$

In order for the disease free state to be stable, we need:

$$trace[J(E_0)] = -(\delta + \mu) - (\alpha + \mu) + \frac{\beta \mu}{\delta + \mu} < 0 \Rightarrow \frac{\beta \mu}{(\delta + \mu)(\delta + \alpha + 2\mu)} < 1,$$

$$det[J(E_0)] = (\delta + \mu)(\alpha + \mu) - (\delta + \mu)\frac{\beta \mu}{\delta + \mu} > 0 \Rightarrow \frac{\beta \mu}{(\delta + \mu)(\alpha + \mu)} < 1.$$

Note that all the parameters in these expressions (i.e., β , μ , δ , α) are positive. Thus, we have that $\frac{\beta\mu}{(\delta+\mu)(\delta+\alpha+2\mu)} < \frac{\beta\mu}{(\delta+\mu)(\alpha+\mu)}$. In other words, $\frac{\beta\mu}{(\delta+\mu)(\alpha+\mu)} < 1$ is a necessary and sufficient condition for the stability of the disease free equilibrium. Hence, our basic reproductive number is $R_0 = \frac{\beta\mu}{(\delta+\mu)(\alpha+\mu)}$, which is the number of infectious cases generated by one infected individual in a population of mostly susceptibles. Note that as δ and α increase, or as β decreases, then R_0 will tend to be less than 1, which makes the disease free state stable. Biologically, this means that as the rates of education of susceptible individuals and recovery from disease increase, or the effective transmission rate decreases, the disease will tend to disappear. In addition, if there was no education ($\delta = 0$) then $R_0 = \frac{\beta}{\alpha+\mu}$. Remember that we assume that each year approximately one fourth of the population leaves and enters the system. This means that μ is a fixed parameter. Thus, the stability of the disease free equilibrium would depend only on the successful transmission and recovery rates. Refer to figures 2 and 3 in the appendix for examples of the dynamics of Model I when R_0 is less and greater than 1, and to figure 7 for a plot of R_0 versus δ .

Next we want to look at the stability of the endemic state:

$$\left(\frac{N(\alpha+\mu)}{\beta} - \frac{N(\delta(\alpha+\mu)+\mu(\alpha-\beta+\mu))}{\beta(\alpha p+\mu)} \frac{N(\delta(\alpha+\mu)+\alpha p(\alpha-\beta+\mu))}{\beta(\alpha p+\mu)} \right).$$

The Jacobean at this equilibrium state is:

$$\begin{pmatrix} -(\delta + \mu) + \frac{\delta(\alpha+\mu)+\mu(\alpha-\beta+\mu)}{\alpha p+\mu} & -(\alpha + \mu) + \alpha(1 - p) \\ -\frac{\delta(\alpha+\mu)+\mu(\alpha-\beta+\mu)}{\alpha p+\mu} & 0 \end{pmatrix}.$$

For stability, we need:

$$\text{trace} = -(\delta + \mu) + \frac{\delta(\alpha + \mu) + \mu(\alpha - \beta + \mu)}{\alpha p + \mu} < 0 \Rightarrow \frac{\delta(\alpha - \alpha p)}{\mu(\beta - \alpha + \alpha p)} < 1,$$

$$\text{determinant} = -[\delta(\alpha + \mu) + \mu(\alpha - \beta + \mu)] > 0 \Rightarrow \frac{\delta(\alpha + \mu)}{\mu(\beta - \alpha - \mu)} < 1.$$

By looking at the conditions of the trace and the determinant we note that $\frac{\delta(\alpha - \alpha p)}{\mu(\beta - \alpha + \alpha p)} < \frac{\delta(\alpha + \mu)}{\mu(\beta - \alpha - \mu)}$. This implies that $\frac{\delta(\alpha + \mu)}{\mu(\beta - \alpha - \mu)} < 1$ is a necessary and sufficient condition for the stability of the endemic state. Moreover, we note that this condition implies $R_0 = \frac{\beta\mu}{(\delta+\mu)(\alpha+\mu)} > 1$. This means that the endemic state is stable if and only if the disease free state is unstable.

3.2 MODEL II

As it was explained before, the second model is modified from the first one. In the second model, each sex has its own successful transmission (β_m, β_f) and recovery (α_m, α_f) rates. Also, we now include the possibility that the condom can fail in preventing the transmission Chlamydia. The probability of condom failure will be denoted as γ . Thus, in the second model we have a flow from the population of educated individuals to the population of infected individuals.

Since we assume constant population, again we know $\lambda = \mu$. Thus $m = \frac{N}{2} = S_m + I_m + E_m$ and $f = \frac{N}{2} = S_f + I_f + E_f$. Then, we can take $E_m = \frac{N}{2} - (S_m + I_m)$ and $E_f = \frac{N}{2} - (S_f + I_f)$, and substitute E_m and E_f in the equations for $\frac{dI_m}{dt}$ and $\frac{dI_f}{dt}$. Then, similar to what we did for the first model, we can reduce system to only the susceptible and infected individuals. In order to study the dynamics of the second model, we linearize the system by finding the general Jacobean as was done for the first system:

$$Jacobian2 = \begin{pmatrix} -(\delta + \mu) - \frac{\beta_m I_f}{N} & (1-p)\alpha_m & 0 & -\frac{\beta_m S_m}{N} \\ \frac{\beta_m I_f(1-\gamma)}{N} & -(\alpha_m + \mu) - \frac{I_f \beta_m \gamma}{N} & 0 & \frac{(2S_m(1-\gamma) + (N-2I_m)\gamma)\beta_f}{2N} \\ 0 & -\frac{\beta_f S_f}{N} & -(\delta + \mu) - \frac{\beta_f I_m}{N} & (1-p)\alpha_f \\ 0 & \frac{(2S_f(1-\gamma) + (N-2I_f)\gamma)\beta_f}{2N} & \frac{\beta_f I_m(1-\gamma)}{N} & -(\alpha_f + \mu) - \frac{I_m \beta_f \gamma}{N} \end{pmatrix}$$

We begin by analyzing the disease free state points

$(S_m, I_m, E_m, S_f, I_f, E_f) = (\frac{N\mu}{2(\delta+\mu)}, 0, \frac{N\delta}{2(\delta+\mu)}, \frac{N\mu}{2(\delta+\mu)}, 0, \frac{N\delta}{2(\delta+\mu)}) = E2_0$ and finding the condition for its stability.

The Jacobean at this state is

$$J(E2_0) = \begin{pmatrix} -(\delta + \mu) & (1-p)\alpha_m & 0 & -\frac{\beta_m \mu}{2(\delta+\mu)} \\ 0 & -(\alpha_m + \mu) & 0 & \frac{\beta_m(\mu+\gamma\delta)}{2(\delta+\mu)} \\ 0 & -\frac{\beta_f \mu}{2(\delta+\mu)} & -(\delta + \mu) & (1-p)\alpha_f \\ 0 & \frac{\beta_f(\mu+\gamma\delta)}{2(\delta+\mu)} & 0 & -(\alpha_f + \mu) \end{pmatrix}$$

We now look at the sub matrix:

$$SubJ = \begin{pmatrix} -(\alpha_m + \mu) & \frac{\beta_m(\mu+\gamma\delta)}{2(\delta+\mu)} \\ \frac{\beta_f(\mu+\gamma\delta)}{2(\delta+\mu)} & -(\alpha_f + \mu) \end{pmatrix}$$

We know that the trace of this matrix is negative. Thus, for stability of the disease free state we need:

$$\det(\text{SubJ}) = (\alpha_m + \mu)(\alpha_f + \mu) - \frac{\beta_m \beta_f (\mu + \gamma \delta)^2}{4(\delta + \mu)^2} > 0 \Rightarrow \frac{\beta_m \beta_f (\mu + \gamma \delta)^2}{4(\delta + \mu)^2 (\alpha_m + \mu)(\alpha_f + \mu)} < 1.$$

Hence, in this case our basic reproductive number is $R_0 = \frac{\beta_m \beta_f (\mu + \gamma \delta)^2}{4(\mu + \delta)^2 (\alpha_m + \mu)(\alpha_f + \mu)}$.

Similar to the first model, we see the influence of β_m , β_f , α_m , α_f , and δ in the stability of the disease free equilibrium. In addition, we have γ , the probability that the condom will fail to protect a person against Chlamydia. Refer to figures 4, 5 and 6 in the appendix for examples of the dynamics of Model II when R_0 is greater and less than 1, and to figure 8 for a plot of R_0 versus δ .

Note that $\lim_{\delta \rightarrow \infty} \frac{\beta_m \beta_f (\mu + \gamma \delta)^2}{4(\mu + \delta)^2 (\alpha_m + \mu)(\alpha_f + \mu)} = \frac{\beta_m \beta_f \gamma^2}{4(\alpha_m + \mu)(\alpha_f + \mu)}$. This means that as the rate at which susceptible individuals get education increases, the eradication of the disease depends more and more on the successful transmission rates, the recovery rates and the probability of condom failure. Obviously, if the probability that condom failure is high, then the disease free state becomes unstable, and the disease persists among the population. If there is no education ($\delta = 0$) then $R_0 = \frac{\beta_m \beta_f}{4(\alpha_m + \mu)(\alpha_f + \mu)}$. Hence, the stability of this equilibrium depends on the transmission and recovery rates, similar to what happened in Model I.

Recall that the definition of education in our models is a student is educated if and only if they use condoms in every sexual contact. Distribution of condoms among high school students does not guarantee the eradication of the disease. Ultimately, no matter how much education is given to the students the eradication of the disease depends on the transmission rates and the recovery rates. One way to help eradicate the disease from the high school population is to add programs that teach students to reduce sexual contacts, for example, by reducing the number of sexual partners and promoting abstinence. This way, the transmission rates β_m, β_f will become smaller and R_0 will be less than 1, meaning that the epidemic will disappear. If the goal is to eradicate the number of sexual contacts among high school students, then education and condom distribution is not enough. However if the goal is to reduce the transmission of Chlamydia, then sex education must be implemented in addition to having condoms available.

To find the stability of the endemic state, one must first look for the endemic points. Due to the many parameters we have, we decided to prove

the existence of the endemic point (see Appendix) It is enough to prove this existence because we note that if $R_0 > 1$ then the epidemic will persist and it is that which we are interested in, whether the epidemic exists or not.

4 STOCHASTIC PROCESS

In order to further understand the dynamics of Chlamydia amongst high school students we analyze the simplest stochastic process. Our stochastic process follows a similar format as our deterministic models. Most definitions, parameters, and variables do not change from Model II. The essential difference is that we now incorporate into the process the change of sexual contact rates of teenagers.

The process begins by introducing only one infected individual into our population of susceptibles. The infected individual then passes on Chlamydia to another high school student. We are interested in the probability of extinction in our system when this event occurs. Let the probability of extinction be θ .

It is important to note that the value found for θ is only a lower bound for the actual value of θ . In reality, the probability can be much higher. This process is only looking at one infected individual infecting a susceptible individual. Since the whole population is susceptible, the chances that he infects another person are higher, because it is easier for him to find a susceptible, when there are no infected. The higher the probability of infecting a susceptible, the lower the probability of extinction. Thus, the actual probability of extinction (θ) would be higher because in reality there would be more than one infected individual, so it is more difficult to infect a susceptible.

Without loss of generality, let the infected individual be a male. Thus we are only concerned with the probability the disease goes to extinction amongst the female population. The probability of extinction amongst the male population is symmetrical to the female probability. This is equivalent to considering a two sex model where $\beta_m = \beta_f = \beta$ and $\alpha_m = \alpha_f = \alpha$. Like with the analysis of Model I, these assumptions create a symmetry between the male and female dynamics, thus reducing it to a one sex model. A one sex model considers interaction between an infected and a susceptible population. The following diagram depicts the dynamics in a one sex population.

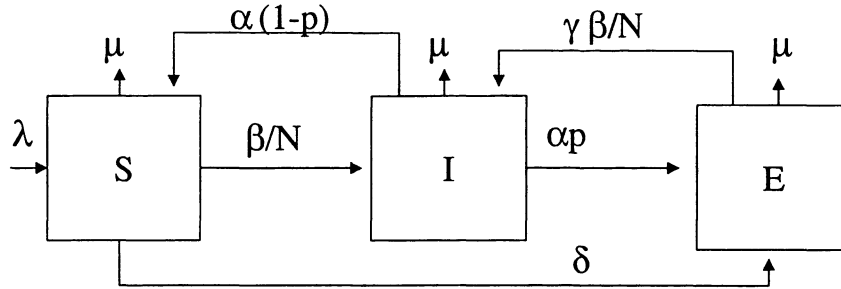

Let θ be the probability of extinction for Chlamydia, where
 $\theta = \text{Probability of no new infections} + \theta^2 \text{Probability of one new infected.}$

The probability of no new infected individuals is equal to

$$\frac{\text{Removal Rate}}{\text{Infected Rate} + \text{Removal Rate}}$$

and the probability of one new infected is equal to

$$1 - \frac{\text{Removal Rate}}{\text{Infected Rate} + \text{Removal Rate}}$$

From the diagram, one can see that the removal rate from the infected class is

$$\alpha(1-p)I + \alpha pI + \mu I$$

and the infection rate is

$$\beta \frac{SI}{N} + \gamma \beta \frac{IE}{N}$$

The removal rate and the new infection rate can be further simplified because the total number of infected individuals in the system (I) is equal to

1. Furthermore, since there is only one infected individual, the proportion of educated students after infection (p) is 0. Thus the educated class (E) is equivalent to δS ; the rate at which students are being educated before an infection occurs. Next, the average time a student spends in high school is 4 years. Thus, the probability that a student taken at random from the population has been in school for t unit of time is $1/4$. Moreover, education occurs at a rate δ , this means that any uneducated student taken at random from the population has a probability to become infected equal to

$$\int_0^4 \frac{1}{4} \text{prob}(\text{education takes place after } t) dt = \int_0^4 \frac{1}{4} \exp(-\delta t) dt = \frac{1 - \exp(-4\delta)}{4\delta}.$$

In addition, $\frac{SI}{N}$ is the probability that an uneducated person becomes infected. Then

$$\frac{SI}{N} = \frac{1 - \exp(-4\delta)}{4\delta}.$$

Similarly, $\frac{EI}{N}$ is the probability that an educated person becomes infected. Then

$$\frac{EI}{N} = 1 - \text{probability of being infected once educated} = 1 - \frac{1 - \exp(4\delta)}{4\delta}.$$

From the above conclusion, the removal rate and infected rate can be rewritten as

$$\text{Removal Rate} = \mu + \alpha$$

$$\text{Infected Rate} = \beta \left(\frac{1 - \exp(-4\delta)}{4\delta} \right) + \left(1 - \frac{1 - \exp(-4\delta)}{4\delta} \right) \gamma.$$

Thus

$$\theta = \frac{(\mu + \alpha)}{(\mu + \alpha) + \beta \left(\frac{1 - \exp(-4\delta)}{4\delta} \right) + \left(1 - \frac{1 - \exp(-4\delta)}{4\delta} \right) \gamma} + \theta^2 \frac{\beta \left(\frac{1 - \exp(-4\delta)}{4\delta} \right) + \left(1 - \frac{1 - \exp(-4\delta)}{4\delta} \right) \gamma}{(\mu + \alpha) + \beta \left(\frac{1 - \exp(-4\delta)}{4\delta} \right) + \left(1 - \frac{1 - \exp(-4\delta)}{4\delta} \right) \gamma}$$

Solving for θ ,

$$\theta = \left\{ 1, \frac{(\mu + \alpha) \delta 4 \exp(4\delta)}{\beta(-1 + \exp(4\delta)) + \gamma - \gamma \exp(4\delta) + 4\gamma \delta \exp(4\delta)} \right\}$$

The probability of extinction (θ) is

$$\theta = \min \left\{ 1, \frac{(\mu + \alpha)\delta 4 \exp(4\delta)}{\beta(-1 + \exp(4\delta)) + \gamma - \gamma \exp(4\delta) + 4\gamma\delta \exp(4\delta)} \right\}.$$

The stochastic process allows us to further see the effects of condom use on Chlamydia rates and sexual contacts amongst teenagers. Amongst high school students, the transmission of STDs is a major concern. At least initially, the availability of condoms may lead students to increase their sexual contacts because they feel protected against STDs. Research and surveys have shown that condom distribution programs do not have a drastic effect on the sexual activity rates. Thus, we assume that β would increase by k , where k is the increase in sexual contacts. We also assume that the sexual contacts would not increase by more than two. In this process, we do not look at the decrease of sexual contacts. Thus the probability of extinction, if the sexual contacts increase by k is

$$\theta = \min \left\{ 1, \frac{(\mu + \alpha)\delta 4 \exp(4\delta)}{k\beta(-1 + \exp(4\delta)) + \gamma - \gamma \exp(4\delta) + 4\gamma\delta \exp(4\delta)} \right\}.$$

If $k=1$, then

$$\theta = \min \left\{ 1, \frac{(\mu + \alpha)\delta 4 \exp(4\delta)}{\beta(-1 + \exp(4\delta)) + \gamma - \gamma \exp(4\delta) + 4\gamma\delta \exp(4\delta)} \right\},$$

giving the probability of extinction without an increase in sexual activity.

The two parameters that we are most interested in are the rate of education (δ) and the increase in sexual contacts (k). We define the probability of extinction, θ , as a function of δ and k . We assume the sexual activity rate of teenagers will at most double if they feel more confident with the use of condoms. Therefore, $1 < k < 2$. The average time a student takes to become educated per year is $\frac{1}{\delta}$. Usually, a student spends four years in high school. In the worst possible case, a student can take all four years to become educated, thus $\delta = \frac{1}{4}$. The best case scenario is a student can become educated the first day they enter high school. Thus, $\delta = \frac{1}{1\text{day}}$. Since there are 365 days in a year, the upper bound for $\delta = 365$. Then, $\frac{1}{4} < \delta < 365$.

Graphing the function of θ allows us to clearly see the effects of δ and k . We use given information and statistics to find values for the other parameters. Most students spend on the average four years in high school ($\frac{1}{\mu}$), thus $\mu = \frac{1}{4}$. The average life span of Chlamydia is $\frac{1}{\alpha}$. A majority of the

infected individuals are asymptomatic until they have other complications. Thus, we assume that the disease will last about half a year, thus $\alpha = 2$. Take γ to be the probability that a condom fails. For high school students the reliability rate is 75%, thus $\gamma = 1 - 0.75 = \frac{1}{4}$. Finally we let $\beta = \frac{52}{3}$. This value was estimated from other gonorrhea and Chlamydia models. The values used for β and α are averages for males and females.

Figure 9 in the appendix graph gives the relationship between δ and k and the probability of extinction. The following discussion looks at figure 9, 10, and 11 in the appendix.

By rotating figure 9, θ can be seen with respect to k ; refer to figure 10. From figure 10, one can observe that as k (the change in sexual contacts) increases, θ (the probability of extinction) decreases. This rotation also allows us to see the relationship between the rate of education (δ) and the increase in sexual contacts (k). As δ increases, the effects of k are minimized and the probability of extinction (θ) increases. From these observations we can conclude that if condoms are readily available in high school then a sex education program on the proper use of condoms has to be given to the students to control the Chlamydia rates. If condoms are made available without education, then it is very likely that the rate of Chlamydia will increase. Thus, education on the proper use of condom is of importance.

By rotating figure 9 one more time, θ can be seen with respect to δ (rate of education); refer to figure 11. As the rate of education increases, the probability of extinction increases. When k is considered and the rate of education (δ) increases, the probability of extinction is lower when $k > 1$. Much like education, an increase in sexual contacts is important to the probability of extinction. From these observations we conclude that as sexual contacts increase, the rate of education also has to increase. Without such provisions, it is very likely that the rate of transmissions for Chlamydia will increase.

The angle of this graph also allows us to see the exact importance of education for this model. The behavior of this function is very intense when δ is between $\frac{1}{4}$ and 40. When δ is greater than 40, the probability of extinction (θ) stabilizes and it is almost constant. This behavior is similar for at values of k . Thus, if we don't have a rate δ of at least 50, which is equivalent to educating the students during the first week of their freshman year, then the probability of extinction will decrease considerably each day that they go uneducated. According to this process, for condom distribution to have a positive affect on Chlamydia rates, education has to occur during the first two weeks of school. This graph shows us that education is very

important in order to control Chlamydia, but the rates we found are too unrealistic. This also tells us that the definition of education is too limiting. Programs throughout the country have showed that condom distribution programs with some education help control Chlamydia rates, even when the education is taking place in the second year of school.

5 IMPROVEMENTS

In general, the conclusions and the analysis of both models gave results that indicated that there was a correlation between the sexual transmission rate and the rate of education. The results from our deterministic models and stochastic process follow intuition and confirm that education is of importance in the control of Chlamydia rates amongst high school students when condoms are readily available. Unlike the stochastic process, the deterministic analysis showed that as the rate of education went to infinity, for set parameters, the disease would never be eradicated, thus education is not sufficient to eradicate the disease, it is only sufficient to decrease the transmission rates of Chlamydia. The general results might lead the reader to conclude that the model is adequate, but there are other results that show that improvements must be made to the model. The results also stress that the definition of education is too encompassing because the average time to educate students necessary to control Chlamydia is too short (2 weeks to seven months after entering the system) and unrealistic. For our models, picking up a condom is equivalent to being educated. Education needs to be more than just picking up a condom. It has to incorporate the idea of knowing how to properly use a condom.

Moreover, having a condom and using a condom are not equivalent. Thus, the model also needs to incorporate a parameter that accounts for the probability that an educated student actually uses a condom after they pick it up. It should be assumed that the probability of the educated student would be higher than that of an uneducated student. Moreover, the model needs to find a relationship between education rates and the availability of condoms. The easier it is to obtain condoms, the greater the need for education.

The model can also be improved by incorporating a different type of pair formation. The present model incorporates a random pair formation which implies that a person in a relationship is just as likely to have sex as a single person. Yet, students in a monogamous relationship are less likely

to contribute to transmission dynamics of Chlamydia than a single student with several partners. Secondly, this model also implies that a virgin is just as likely as a non-virgin to have sex. The sexual contact rate for a single high school student is a lot lower than the rates of a couple. The model should also incorporate the different probabilities of having sex if you are a virgin or not.

All of the above improvements would affect both the deterministic models and stochastic process because the stochastic process is derived from the deterministic model. One difference between the stochastic process and the deterministic models is that the stochastic process accounts for the change in sexual contacts due to an increase in the confidence levels amongst high school students due to the availability of condoms. This idea should also be incorporated into the deterministic models. The deterministic model is only concerned with the Chlamydia transmission rate, not with the rate of sexual contacts.

Like the deterministic model, the stochastic process also needs improvements separate from the deterministic model. In particular, the process needs to look at the probability of extinction when an individual infects N individuals instead of just one. This would be a more appropriate estimation for the probability of extinction. The process should also look at the probability of extinction when N infected individuals are introduced into the system.

6 CONCLUSION

It is important to make a comparative analysis of the two different methods of analyzing the problem to eradicate the transmission of Chlamydia. The stochastic process was derived from our deterministic model, therefore we expected the results to be compatible. The stochastic process follows the general format of Model II which incorporates condom failure. However, the analysis indicated very different results for each model.

Model II indicated that as the amount of education increases, eradication of the disease still depends on the transmission rates. Condom distribution and education is not effective enough for the eradication of the disease. However, if the transmission rates are decreased, then the number of new cases of Chlamydia will decrease. If high schools want to decrease the sexual contact rates, they must also provide programs to promote safe sex and abstinence with the distribution of condoms.

The stochastic process, on the other hand, shows the direct relationship between the increase of sexual activity and education implies the higher probability of extinction for Chlamydia. This indicates that education and condom availability is essential to reduce Chlamydia cases given an increase in sexual activity among students.

In our stochastic process, we found that the average time needed to educate the students is seven weeks. While the deterministic model indicated that for the eradication of Chlamydia to occur, students must be educated within the first seven months they enter school.

There are some important differences which contribute to the different education values we found. In the Model I, we find that once condom failure is included, the eradication of the disease is more dependent on the contact rates of the individuals and less on the education. Moreover in the stochastic process, the education was also dependent on the confidence factor, which was not included in the deterministic process. Finally, the deterministic models look at an average rate, while the stochastic process provides a value for a specific case.

In both the stochastic process and the deterministic models we find that education and condoms are important to the eradication of the disease. We note that the values we found for education are unrealistic because of the definition given to education. Thus, the education parameter needs a more specific definition. The definition of education must be independent of condom availability. Nevertheless, the results support the method of condom distribution with sex education to control the STD's in high school.

Sometimes, school officials recommend the distribution of condoms to students without educating them on the proper use. Our research supports both education and condom distribution as an effective combination to control Chlamydia rates. Giving the condoms to students without having the proper education is not enough according to the conclusions of our models. We note that whether or not the sexual activity of students increase, education plays a major role in eradicating any sexually transmitted disease.

ACKNOWLEDGMENTS

The research in this manuscript has been partially supported by grants given by the National Science Foundation (NS Grant DMS-9600027), the National Security Agency (NSA Grant MDA 904-96-1-0032 and MDA-904-97-1-0074) and a Presidential Faculty Fellowship Award (NSF Grant DEB 925370) given to Carlos Castillo-Chavez. Substantial financial and moral support was also provided by the Office of the Provost of Cornell University and by Cornell's College of Agricultural & Life Science (CALS) and its Biometrics Unit. The authors are solely responsible for the views and opinions expressed in this report. The research in this report does not necessarily reflect the ideas and/or opinions of the funding agencies and/or Cornell University.

We would like to thank the following people for all the help, support, and motivation they gave us throughout this summer and especially during the final critical stages of our research project: Carlos Moises Hernandez-Suarez, Carlos Castillo-Chavez, John Alderete, Song Baojun, Abdul-Aziz Yakubu, Maia Martcheva, Zhilan Feng, Steve Wirkus, Ricardo Saenz, Julio Villarreal, and to all persons that we have failed to mention but have not forgotten. We especially thank NSA, SACNAS, and the Mathematical & Theoretical Biology Institute (MTBI) for Undergraduate Research, Biometrics Unit at Cornell University for allowing us to participate in this research program.

REFERENCES

- Bowler, S., A. Sheon, L. D'Angelo, S. Vermund. HIV and AIDS among adolescents in the United States: increasing risk in the 1990s. *Journal of Adolescence*. 1992;(15) 345-371.
- Brown, N. L., M. Pennylegion, and P. Hillard. A Process Evaluation of Condom Availability in the Seattle, Washington Public Schools. *The Journal of School Health*. 1997; 67(8):336-340
- Centers for Disease Control and Prevention. July 12, 1998. World Wide Web Page. http://www.cdc.gov/nchstp/dstd/chlamydia_facts.htm
- Centers for Disease Control and Prevention. July 12, 1998. World Wide Web Page. <http://www.cdc.gov/nchstp/dash/yrbs/suse.htm#top>
- Colberg, J. 1997. *Red Light, Green Light: Preventing Teen Pregnancy*. Montana: Summer Kitchen press.
- Hethcote, H. 1984. *Gonorrhea Transmission Dynamics and Control*. New York: Springer-Verlag.
- Healthy Devil Online. July 27, 1998. World Wide Web Page. <http://h-devil-www.mc.duke.edu/h-devil/stds/cmydia.htm>
- Moore, S. D. Rosenthal, A. Mitchell. 1996. *Youth, AIDS, and Sexually Transmitted Diseases*. New York: Routledge.
- Rolonda. *Teens Talk About Sex: Adolescent Sexuality in the 90's. A Survey of High School Students*. Roper Starch.
- United States Congress: Committee on Energy and Commerce. 1986. *Incidence and Control of Chlamydia: Hearing before the Subcommittee on Health and the Environment of the Committee on Energy and Commerce*. Washington: US G.P.O.
- Wolk, L., R. Rosenbaum. The Benefits of School-Based Condom Availability: Cross-Sectional Analysis of a Comprehensive High School-Based Program. *Journal of Adolescent Health*. 1995(17): 184-188.
- Yim, T., G. Russo, S. La Croix. *Condom Use in the Presence of HIV Risk: The Role of Economic and Epidemiological Variables*. East-West Center Working Papers. 1993; 69.

APPENDIX

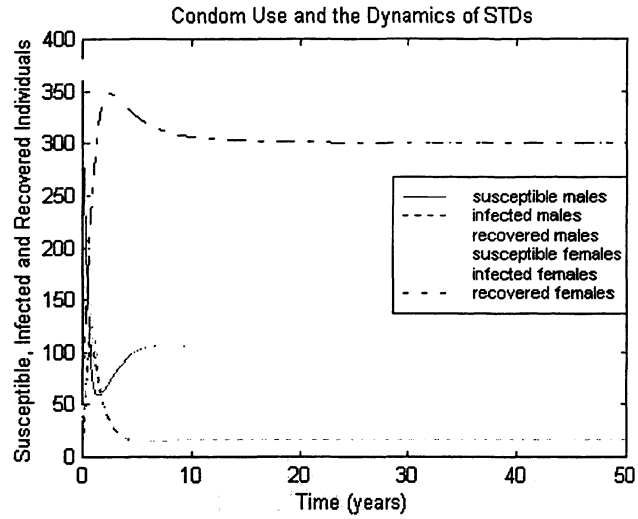

Figure 1: This graph shows the dynamics of the populations of susceptible, infected and recovered individuals in a time interval of 50 years (Model I). Initial values: $S_m = 300$, $I_m = 10$, $R_m = 40$, $S_f = 380$, $I_f = 35$, $R_f = 80$. Parameters: $\lambda = \mu = 0.25$, $\beta = 18$, $\delta = 0.5$, $\alpha = 2$, $p = 0.7$.

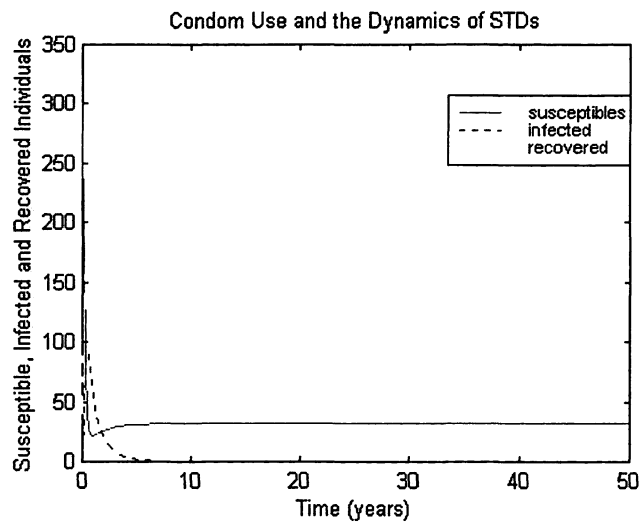

Figure 2: This graph shows an example of the dynamics of Model I when $R_0 < 1$. In this case, the population of infected individuals will disappear after a period of approximately seven or eight years. $R_0 = 0.7273$. Initial values: $S = 300$, $I = 10$, $R = 40$. Parameters: $\lambda = \mu = 0.25$, $\beta = 18$, $\delta = 2.5$, $\alpha = 2$, $p = 0.7$.

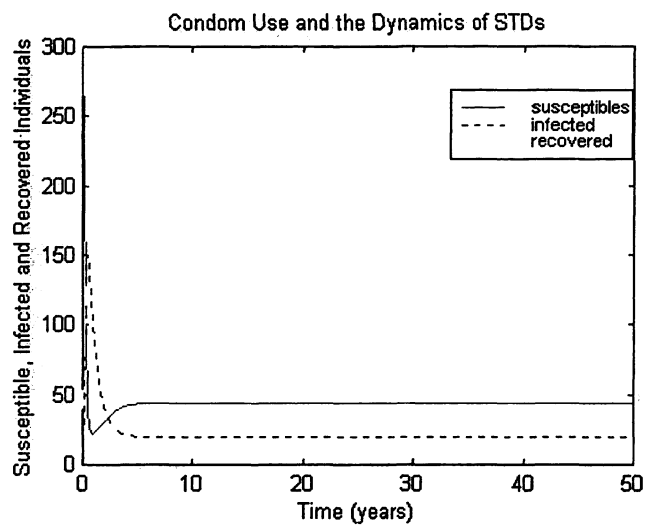

Figure 3: This is an example of the dynamics of Model I when $R_0 > 1$. Note the persistence of infected individuals and the stabilization of the different populations after a relatively small period of time. $R_0=1.6$. Initial values: $S = 300$, $I = 10$, $R=40$. Parameters: $\lambda=\mu=0.25$, $\beta=18$, $\delta=1$, $\alpha=2$, $p=0.7$.

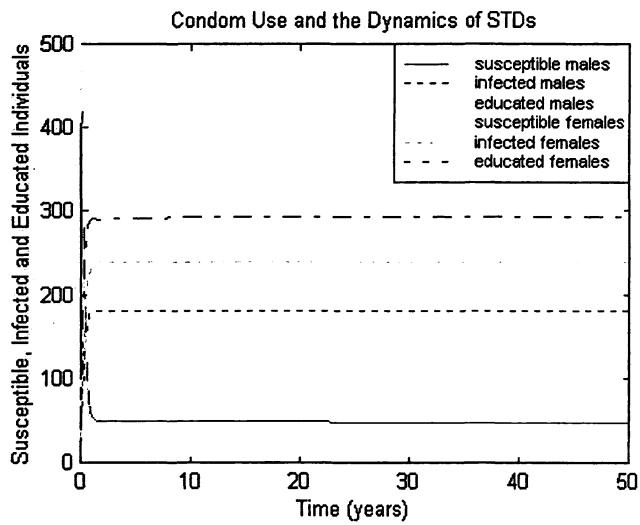

Figure 4: The preceding graph shows an example of the dynamics of Model II when $R_0 > 1$. $R_0 = 2.3467$. Initial values: $S_m = 500$, $I_m = 50$, $E_m = 30$, $S_f = 500$, $I_f = 30$, $E_f = 40$. Parameters: $\lambda = \mu = 0.25$, $\beta_m = 14.4$, $\beta_f = 23.1$, $\delta = 2$, $\alpha_m = 2$, $\alpha_f = 1.5$, $p = 0.7$, $\gamma = 0.25$.

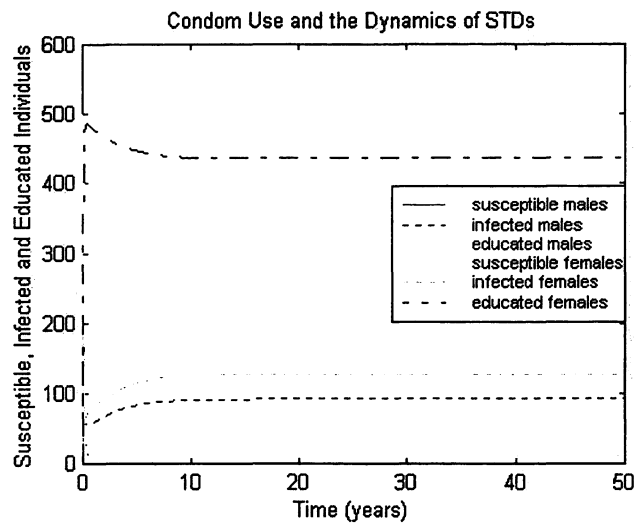

Figure 5: This graph shows an example of the dynamics of Model II when $R_0 > 1$. $R_0 = 1.4530$. Initial values: $S_m = 500$, $I_m = 50$, $E_m = 30$, $S_f = 500$, $I_f = 30$, $E_f = 40$. Parameters: $\lambda = \mu = 0.25$, $\beta_m = 14.4$, $\beta_f = 23.1$, $\delta = 15$, $\alpha_m = 2$, $\alpha_f = 1.5$, $p = 0.7$, $\gamma = 0.25$.

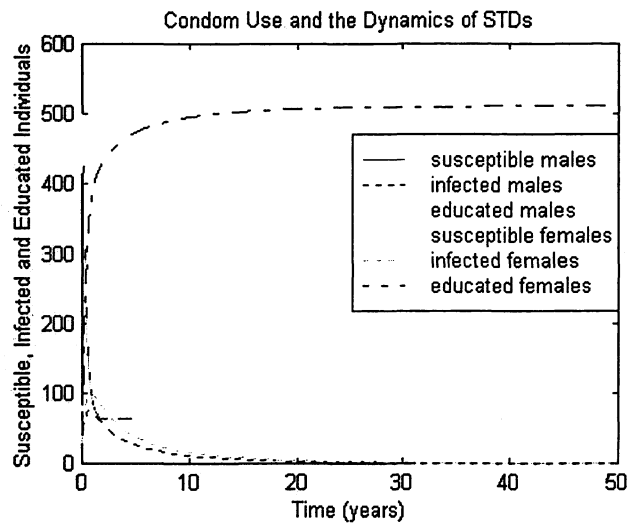

Figure 6: This is an example of the dynamics of Model II when $R_0 < 1$. $R_0=0.8889$. Initial values: $S_m=500$, $I_m=50$, $E_m=30$, $S_f=500$, $I_f=30$, $E_f=40$. Parameters: $\lambda=\mu=0.25$, $\beta_m=9$, $\beta_f=14$, $\delta=2$, $\alpha_m=2$, $\alpha_f=1.5$, $p=0.7$, $\gamma=0.25$.

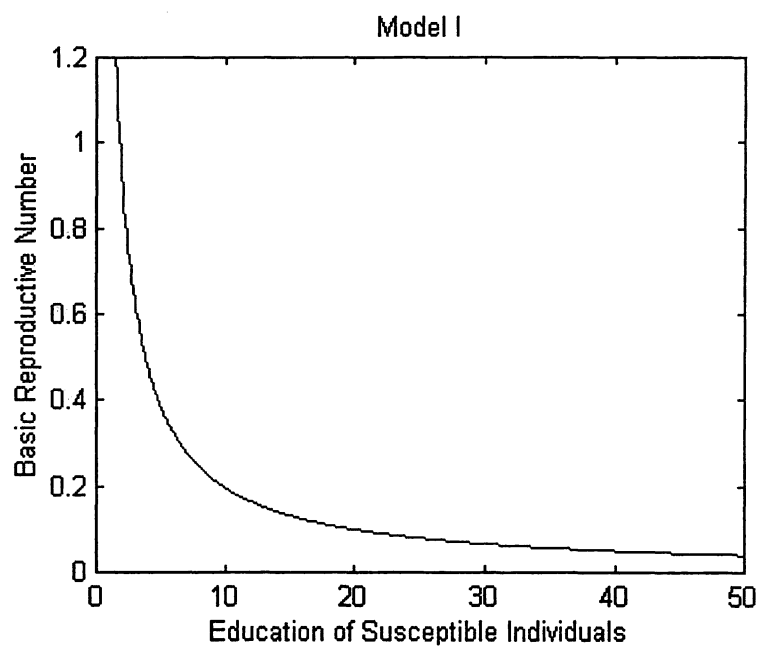

Figure 7: This is a plot of R_0 versus δ for Model I. We can see that as δ increases R_0 decreases. It becomes smaller than 1 when δ is greater than 1.75.

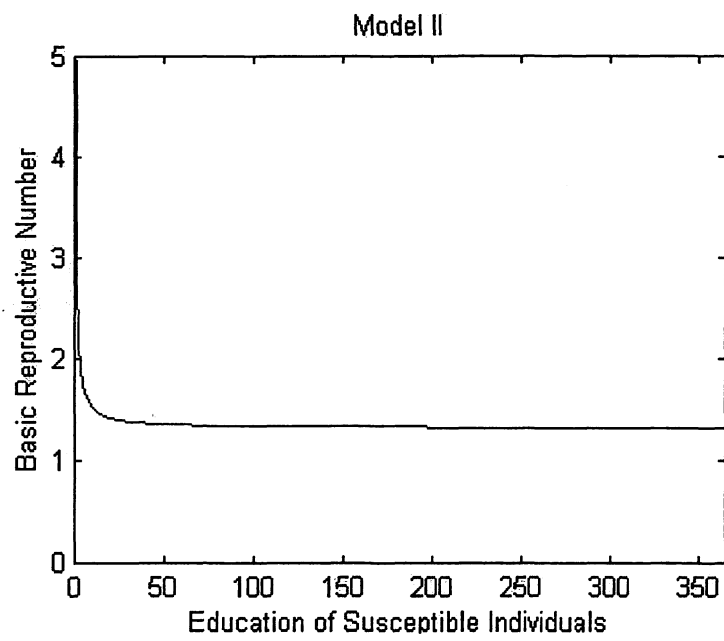

Figure 8: This graph shows R_0 versus δ for Model II. As in the first model, R_0 decreases as δ increases. Unlike Model I, R_0 will not reach the value of 1 as δ grows, but is low bounded by the value of 1.4.

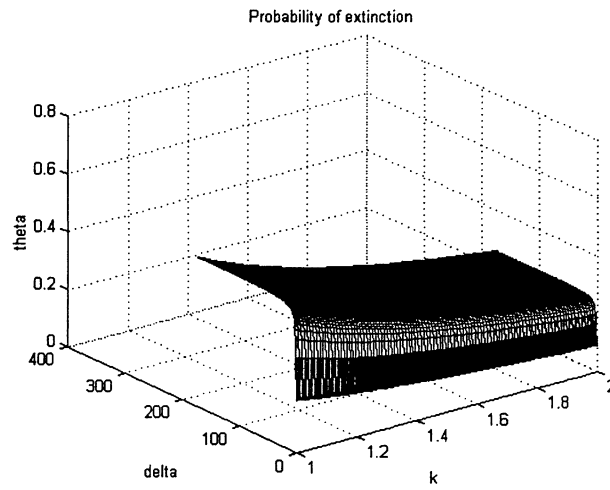

Figure 9: This graph look at the relationship between the probability of extinction (θ), the change in sexual contacts, and the rate of education (δ) when all the other parameters are set. Let $\mu = \frac{1}{4}$, $\beta = \frac{52}{3}$, $\gamma = \frac{1}{4}$, and $\alpha=2$.

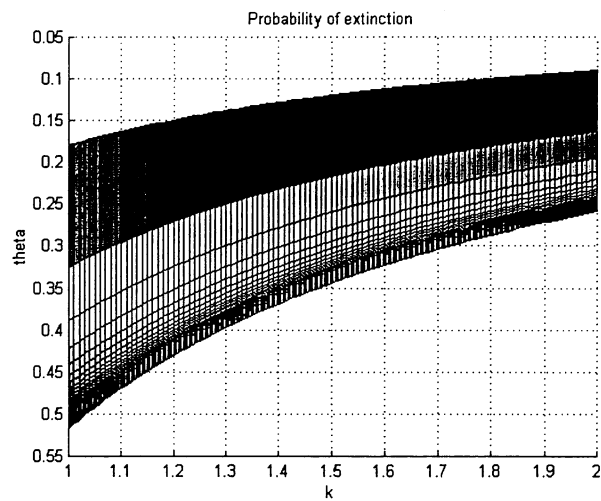

Figure 10: By rotating figure 9, the relationship between theta and k can be observed. It is observed that as k increases the probability of extinction decreases. Furthermore, as the rate of education increases, the probability of extinction also increases. Thus, delta minimizes the effects of k.

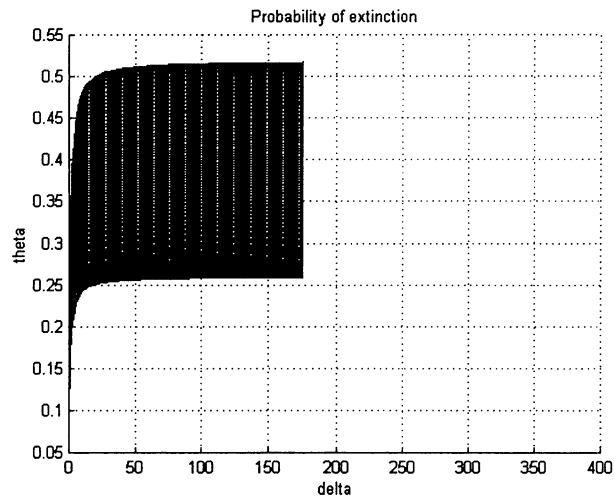

Figure 11: By rotating figure 9 once more, the relationship between the rate of education (δ) and the probability of extinction (θ) is displayed. As the rate of education increases, the probability of extinction increases. The lower the change in sexual contacts, the higher the probability of extinction.

PROVING THE ENDEMIC POINT

Let

$$x1 = \frac{S_m}{N}$$

$$x2 = \frac{S_f}{N}$$

$$y1 = \frac{I_m}{N}$$

$$y2 = \frac{I_f}{N}$$

It is enough to solve for these four proportions. With this we can also find the proportion of educated population. Recall that $S_m + I_m + E_m = M$ and $S_f + I_f + E_f = F$ and $F + M = N$ (total population)

We then try to find the endemic point in terms of these proportions. We let $\frac{dI_{m,f}}{dt} = 0$ and $\frac{dS_{m,f}}{dt} = 0$ to find the equilibrium point at the endemic state.

We solve:

$$0 = \frac{\mu}{2} - \beta_m x1 y2 - \delta x1 + \alpha_m (1-p)y1 - \mu x1$$

$$0 = \beta_m x1 y2 + \beta_m \gamma \left(\frac{1}{2} - x1 - y1\right) y2 - \alpha_m y1 - \mu y1$$

We are then able to solve for the different proportions of the population.

$$x2 = \frac{\alpha_f(1-p) y2 + \frac{1}{2} \mu}{\beta_f y1 + \delta + \mu} = \text{proportion of susceptible females}$$

$$x1 = \frac{\alpha_m(1-p) y1 + \frac{1}{2} \mu}{\beta_m y2 + \delta + \mu} = \text{proportion of susceptible males}$$

$$y1 = \frac{(\beta_m x1 + \beta_m \gamma \left(\frac{1}{2} - x1\right)) y2}{\beta_m \gamma y2 + \mu + \alpha_m} = \text{proportion of infected males}$$

$$y2 = \frac{(\beta_f x2 + \beta_f \gamma \left(\frac{1}{2} - x2\right)) y1}{\beta_f \gamma y1 + \mu + \alpha_f} = \text{proportion of infected females}$$

After some algebraic manipulation:

$$y_1 = \frac{(1-\gamma)(\beta_m \alpha_m (1-p) y_1 y_2 + \frac{1}{2} \beta_m \mu y_2) + \frac{1}{2} \beta_m \gamma (\beta_m y_2 + \delta + \mu)}{(\beta_m y_2 + \delta + \mu) (\beta_m \gamma y_2 + \mu + \alpha_m)}$$

$$A = (1 - \gamma)$$

$$B = \frac{1}{2} \beta_m \mu y_2$$

$$C = \frac{1}{2} \beta_m \gamma$$

$$D = \beta_m y_2 + \delta + \mu$$

$$E = \beta_m \gamma y_2 + \mu + \alpha_m$$

$$Q = \beta_f^2 \gamma$$

$$R = \beta_f J + \beta_f \gamma H - A L$$

$$S = \beta_m^2 \gamma$$

$$T = \beta_m I + \beta_m \gamma H - A K$$

$$U = A G \mu + G \beta_f \gamma$$

$$V = A F \mu + F \beta_m \gamma$$

$$W = G H \gamma$$

$$X = F H \gamma$$

$$y1 = \frac{(1-\gamma)\beta_m \frac{1}{2} \mu y2 + \beta_m \gamma \frac{1}{2} (\beta_m y2 + \delta + \mu)}{(\beta_m y2 + \delta + \mu)(\beta_m \gamma y2 + \mu + \alpha_m) - (1-\gamma)\beta_m \alpha_m (1-p) y2}$$

$$y2 = \frac{(1-\gamma)\beta_f \frac{1}{2} \mu y1 + \beta_f \gamma \frac{1}{2} (\beta_f y1 + \delta + \mu)}{(\beta_f y1 + \delta + \mu)(\beta_f \gamma y1 + \mu + \alpha_f) - (1-\gamma)\beta_f \alpha_f (1-p) y1}$$

$$y1 = \frac{VPO + XP^2}{SO^2 + TPO + IHP^2}$$

$$y1 = VQU$$

For the numerator

$$a = XQ^2$$

$$b = VQU + 2QRX$$

$$c = (QW + RU)V + X(2QJH + R^2)$$

$$d = (RW + JHU)V + (2RJH)X$$

$$e = JHWV + JH^2X$$

For the denominator

$$f = IHQ^2$$

$$g = TQU + (IH2QR)$$

$$h = SU^2 + (QW + RU)T + IH(2QJH + R^2)$$

$$i = 2SUW + T(RW + JHX) + IH(2RJH)$$

$$j = W^2S + TJW + IJ^2H^3$$

$$k = g-a$$

$$l = h-b$$

$$m = i-c$$

$$n = j-d$$

We finally find that the proportion of infected males is equal to:

$$y1 = \frac{ay1^4 + by1^3 + cy1^2 + dy1 + e}{fy1^4 + gy1^3 + hy1^2 + iy1 + j}$$

Therefore we can solve for $y1$ by solving for the following equation:

$$0 = fy^5 + ky^4 + ly^3 + my^2 + ny - e = f(y1)$$

Because the equations were not even timely solvable with Mathematical we decided to plug in for the parameters values that were reasonable and that will make $Ro > 1$ for the endemic state. Therefore the same values that are used for the stochastic model are used here plus $\delta = .01$. With this we can then solve for $y1$, the proportion of infected males.

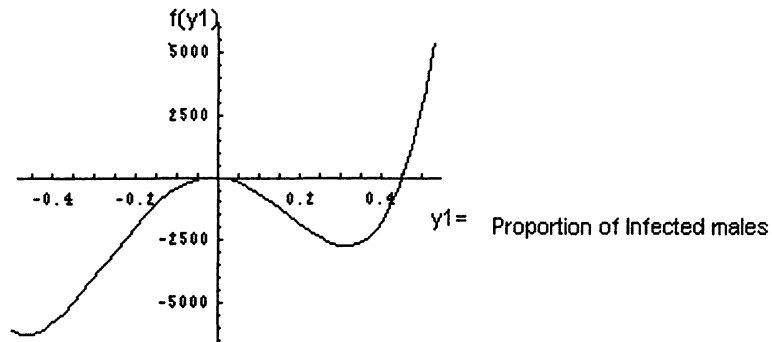

We see here that $y_1=0$ for the disease free state and also $y_1= 0.4$ for the endemic point. Therefore we see that there is actually an endemic point. After we solve for the other proportions we find that the proportions are equal to 1 which accounts for the total population = $\frac{N}{N}$.